

NSK

MEGATORQUE MOTOR™ SYSTEM

Start-up Guide (Driver Model EGA)

NSK Ltd.

Document No.C20195-02

1. Preface

This manual describes necessary procedure to perform PB motor operation as a startup guide. Refer manual M-E099GA0C2-191 for detail.

Please use application software “MEGATORQUE MOTOR SETUP” to set parameter setting value of model EGA driver. “MEGATORQUE MOTOR SETUP” is a free software which can be downloaded from NSK Website.

(<http://www.nsk.com/>)

2. System configuration

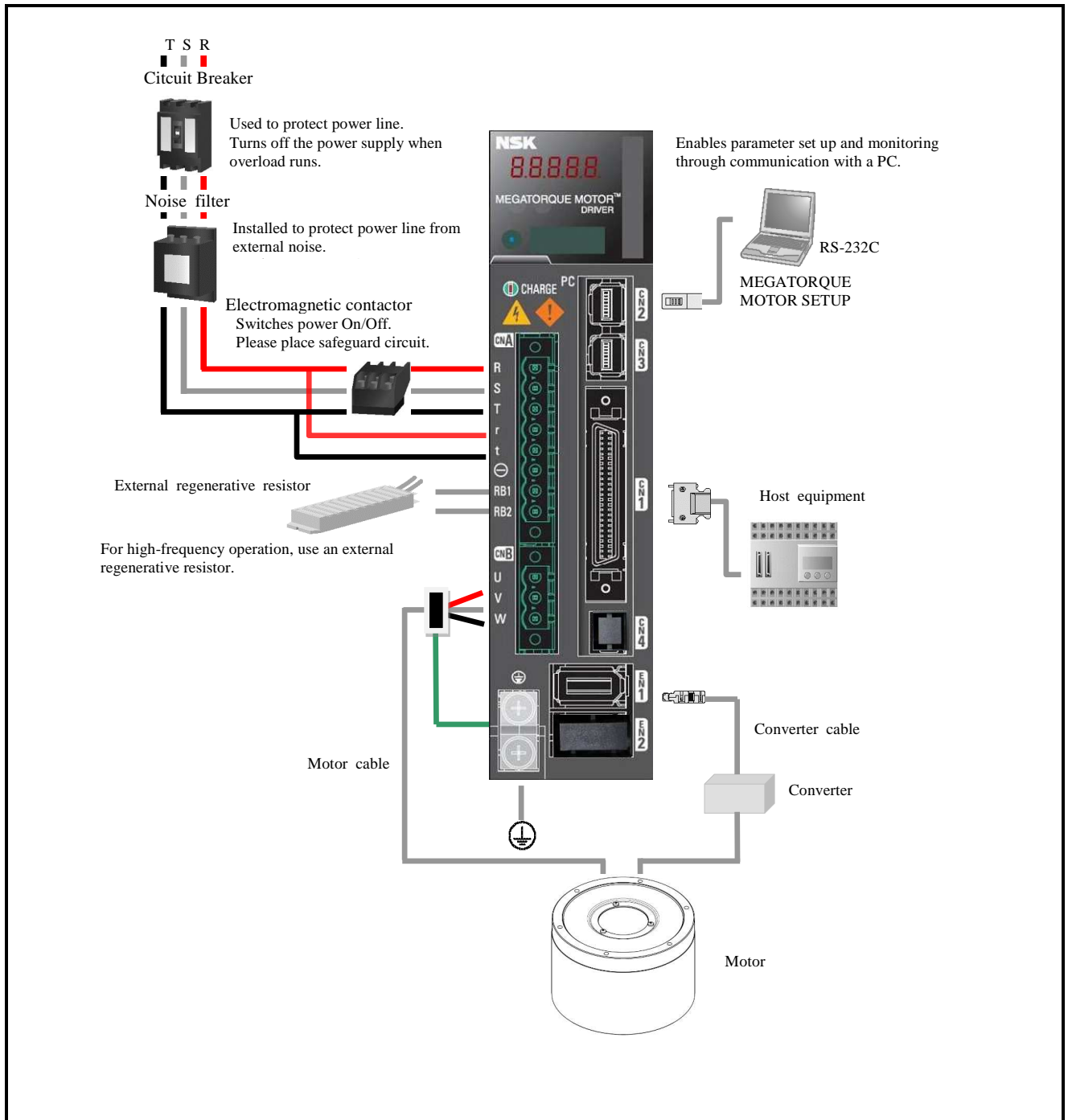

3. Motor of installation

Install and secure the Motor on a rigid base, otherwise mechanical vibrations may occur. And fail to magnetic pole detecting.

OK

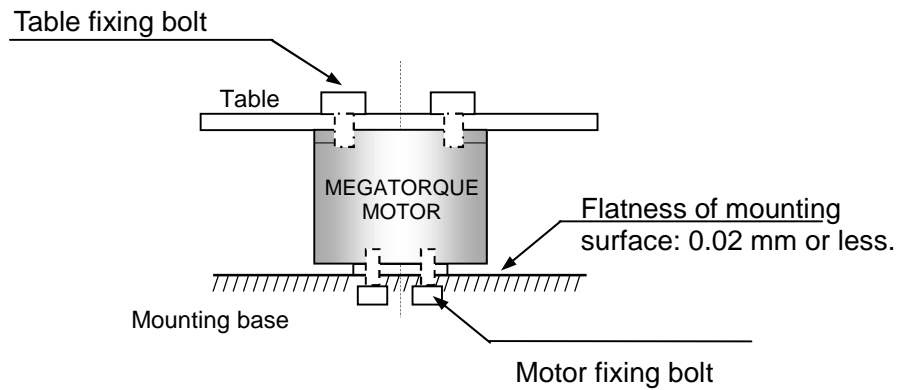

NG

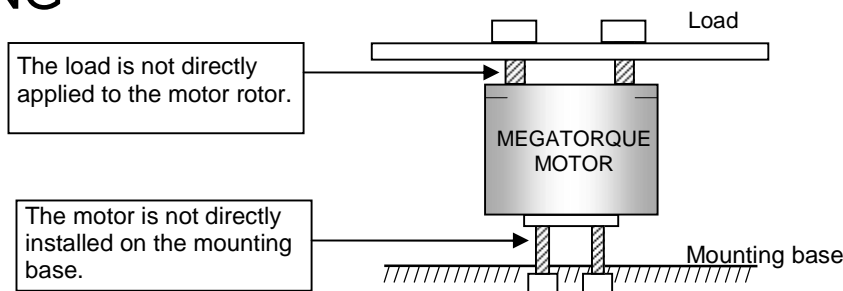

Checking the operating conditions

The MEGATORQUE MOTOR system involves significantly larger moment of inertia for load compared to the moment of inertia for rotor.

- ✓ Remember to check for appropriate allowable moment load, allowable axial load and allowable radial load for your specific applications of the motor.

CN1 signal and Pin number.

CN1 10150-3000PE (Soldering side view)

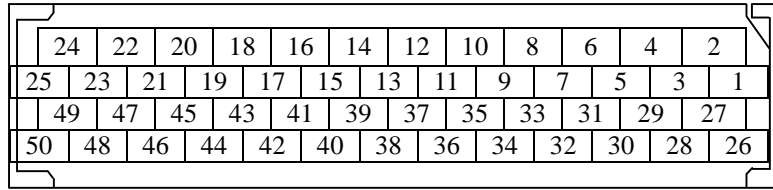

Signal name and its function. (shipping set)

Terminal number	Signal name	Description
1	-	Do not connect
2	-	Do not connect
3	A0	A phase pulse output
4	A0	/A phase pulse output
5	BO	B phase pulse output
6	BO	/B phase pulse output
7	ZO	Z phase pulse output
8	ZO	/Z phase pulse output
9	PS	Resolver signal output
10	PS	/Resolver signal output
11	ZOP	Z phase pulse output
12	SG	Common for pins 3 to 11
17	-	Do not connect
18	-	Do not connect
19	-	Do not connect
20	-	Do not connect
21	-	Do not connect
22	T-COMP	Torque compensation input
23	SG	Common for pin 22
26	F-PC	CW command pulse input
27	F-PC	CW command pulse input
28	R-PC	CCW command pulse input
29	R-PC	CCW command pulse input
47	SG	Common for pins 26 and 27
48	SG	Common for pins 28 and 29

Terminal number	Signal name	Description
30	MON1	Analog monitor output
31	SG	Common for pin 30
13	CONT7	Position command pulse disabled function/shutdown at zero velocity function
14	CONT7	
15	CONT8	Alarm reset function
16	CONT8	
38	SG	Common for pins 13 to 16
32	CONT6	CW over travel function
33	CONT5	CCW over travel function
34	CONT4	Deviation clear function
35	CONT3	Magnetic pole position estimation input
36	CONT2	Emergency stop function
37	CONT1	Servo-ON function
50	CONT-COM	General input power supply
39	OUT1	In-Position window
40	OUT2	Magnetic pole position estimation ready
41	OUT3	Operation setup completion
42	OUT4	Magnetic pole position estimation end
43	OUT5	Alarm code bit 5
44	OUT6	Alarm code bit 6
45	OUT7	Alarm code bit 7
46	OUT8	Alarm status
49	OUT-PWR	Power source for general output
24	OUT-COM	General output Common
25	OUT-COM	General output Common

4. CN1 wiring example

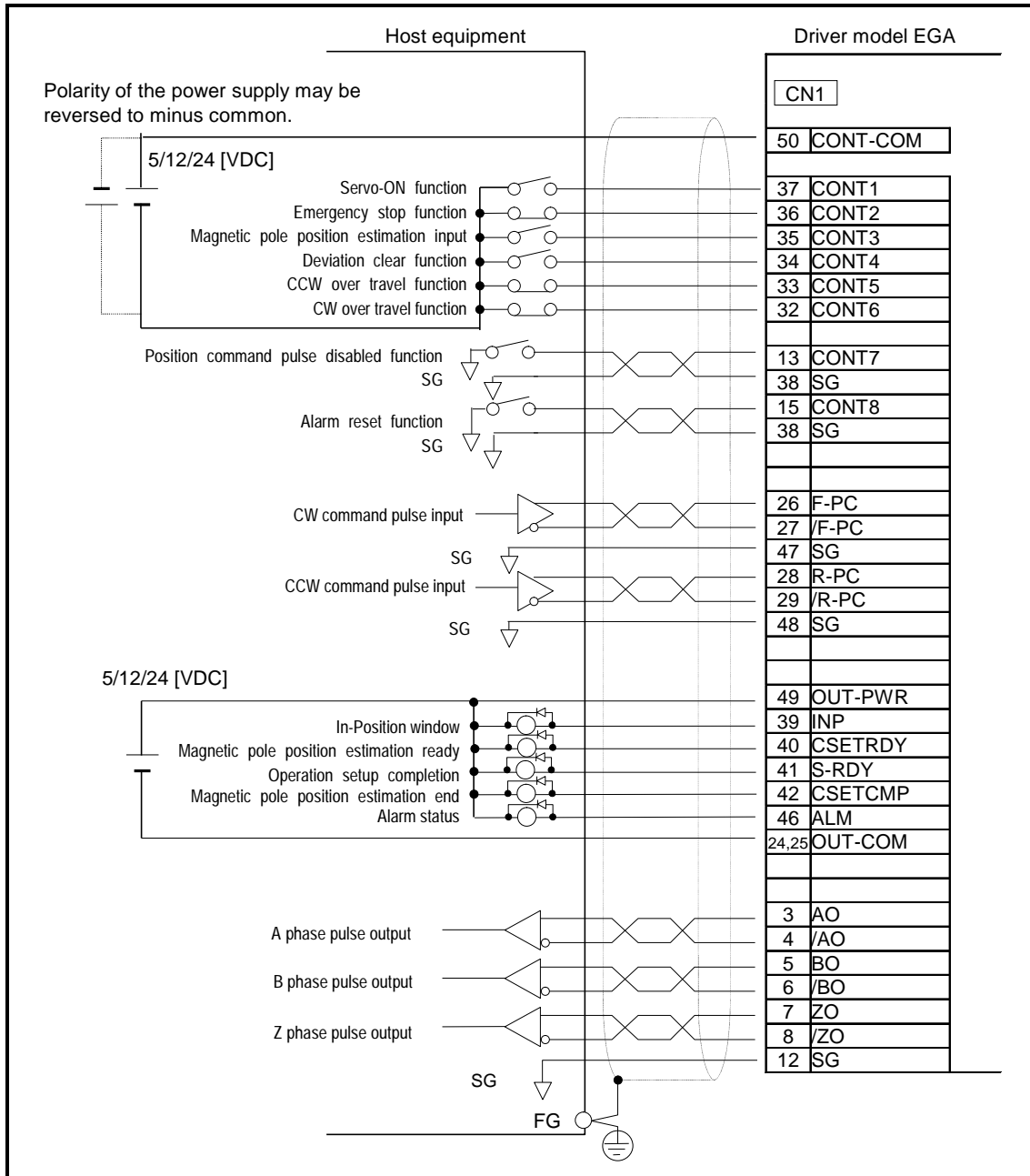

5. Initial setting

Please change parameter setting value of Model EGA driver required according to the conditions to be used. Use application software “MEGATORQUE MOTOR SETUP” to set the parameters.

Single phase AC main power

Change “System parameter_ID01 : main circuit power input type” to “01 : AC Single-phase”, then connect AC power line to terminal R and T of connector CNA.

CN1 I/O signal configuration

The pin-out arrangement and polarity of signals from CONT1 to CONT8 can be changed by setting of parameter “Gr.9_Function enabling condition settings”, and pin-out arrangement of signals from OUT1 to OUT8 can be changed by “Gr.A_General output terminal output condition / Monitor output selection / Serial communication settings”.

Input signals “Gr.9_ID00: CW Over Travel function(F-OT)”, “Gr.9_ID01: CCW CW Over Travel function(R-OT)”, and “Gr.9_ID42: Emergency Stop Function(EMR)” are normal close polarity input as shipping set.

To enable motor operation, wire these input signals properly, or change its polarity by parameter setting value.

6. Operation sequence

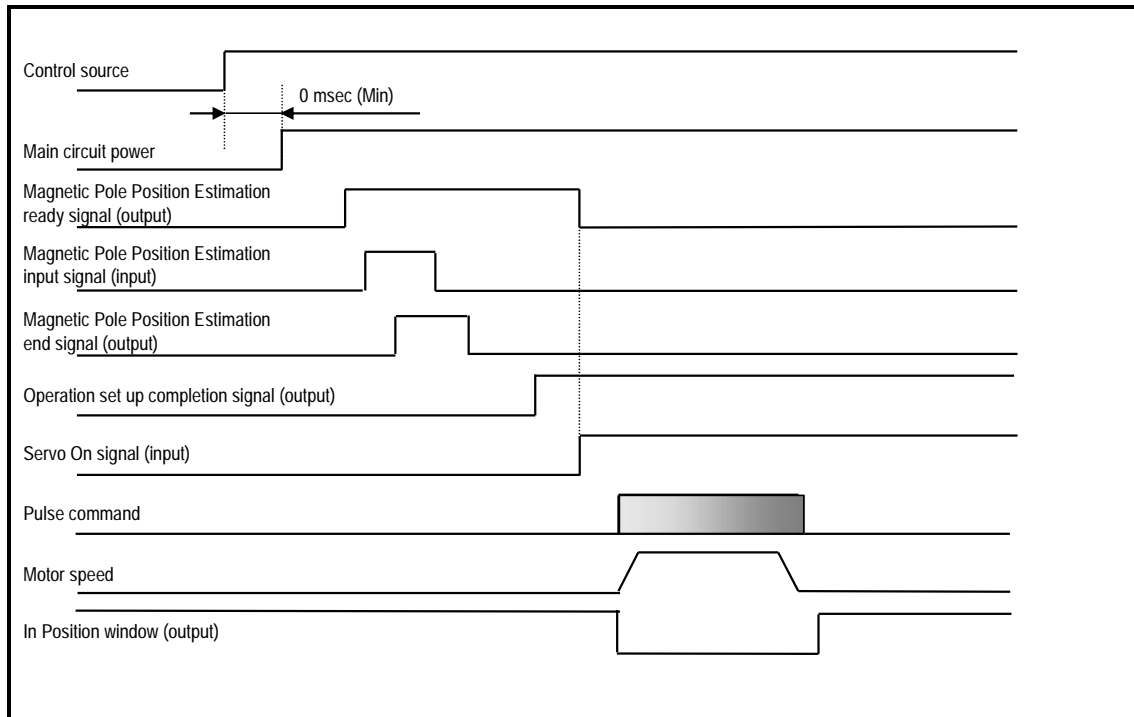

 **Caution :** The magnetic pole position estimation must be conducted everytime when power is turned on.

- Magnetic pole position estimation will cause the motor rotation reciprocally maximum of +/-18 degree.
Do not apply external and/or unbalanced force to the motor to complete magnetic pole position estimation process properly.
- Start motor operation after completion of magnetic pole estimation process.

 **Caution :** Install external Home sensor if homing operation is required.

- Motor incorporates incremental sensor, no absolute sensor is incorporated.

7. Motor operation

Ste	Content
1	Confirm wiring for Input and Output signals.
	Confirm wiring for Input / Output signals work properly by Host equipment and application software "MEGATORQUE MOTOR SETUP".
2	Set Tuning mode and Load inertia moment ratio. Set Tuning mode "Gr.0_ID00 : Tuning mode (TUNMODE)" to 01 : AutoTun_JRAT-Fix".
	Set the ratio of Load moment inertia against Motor rotor inertia to "Gr.1_ID14:Load inertia moment ratio 1 (JRAT1)". □ JRAT1 setting value = (Load moment inertia) / (Motor rotor inertia) × 100 [%]
3	Execute Magnetic pole position estimation.
	Close "Magnetic pole position estimation" input after confirming "Magnetic pole position estimation ready" output. Motor will start maximum +/-18 degree reciprocal motion.
4	Close Servo On.
	Close Servo On input signal. Confirm motor servo against external force, and 7 segment display on the front panel of model EGA driver shows character "8".
5	Input pulse command. Input Pulse command to model EGA driver.
	In case of no motor motion, please check pulse command from host equipment to model EGA driver which can be confirmed by monitor function "Monitor_ID13 : Command pulse frequency (FMON1)". No number ("0") appears on monitor if Model EGA driver does not receive position command pulse from host equipment. Please check wiring from host equipment to model EGA driver.
	Note:
	Apply slow motor speed pulse command to confirm motor speed and motor rotating direction with secured interlock signals such as Emergency stop and Over travel. Stop motor operation immediately in case of any abnormal motion. Shipping set of Tuning mode "Gr.0_ID00 : Tuning mode (TUNMODE)" is "00" as Auto-tuning for such as servo gain and is valid.

■ Display of the Digital operator

NO	Display	Description	Check points to get proper state
1		Control power supply established. Control power supply (r, t) is established, and driver ready (RDY) is ON.	-
2		Main circuit power supply established. Main power supply (R, S and T) is established, but operation preparation completion signal is OFF.	• Confirm main AC voltage line connected to model EGA driver.
3		Operation preparation completion signal is established. Main power supply (R, S and T) is established, and operation preparation completion signal is ON.	• Confirm input signal polarity of Over travel and Emergency stop. • Confirm magnet pole position estimation has completed properly.
4		Servo is ON. Segment repeats on and off individually to display character "8".	• Confirm Servo On input signal is closed properly.

8. Important notation.

8.1 Ratio of Load moment inertia against Motor rotor inertia.

Model EGA driver features Auto Tuning function which generates servo parameters automatically by parameter setting value of ratio of Load moment inertia against Motor rotor inertia, and motor responsiveness. No Manual tuning is required if motor performance is fully satisfied.

Before starting motor operation, change parameter setting of “Gr.0_ID00:Tuning mode(TUNMODE)” to “01 : AutoTun_JRAT-Fix”(This setting changes a mode from a real time auto tuning mode to an auto tuning mode), then enter ratio of Load moment inertia against motor rotor inertia to “Gr.1_ID14:Load inertia moment ratio 1 (JRAT1)”.

Please refer PB motor catalog for the value of Motor rotor inertia. Motor operation does not required to enter value to “Gr.1_ID14:Load inertia moment ratio 1 (JRAT1)”.

Formula for Load inertia moment ratio JRAT1:

$$\text{JRAT1} = (\text{Load moment of inertia}) / (\text{Motor rotor moment of inertia}) \times 100 \quad [\%]$$

【Example】

- Load moment of inertia : 0.026 [kg · m²]
- Motor rotor moment of inertia : M-PB1006JN001 : 0.0026 [kg · m²]

$$\text{JRAT1 setting value} = (0.026 / 0.0026) \times 100 = 1000 \quad [\%]$$

If Load moment of inertia value is not available, enter value listed in the table below as a temporary setting value.

Temporary setting value of Load moment of inertia ratio	
Load moment of inertia	JRAT1 : Load moment of inertia ratio [%]
Relatively small	1000
Relatively large	5000

Although temporary setting value for JRAT1 may able to provide some degree of performance, enter proper JRAT1 value for faster motor speed and better accuracy positioning operation.

To improve responsiveness of motor motion and positioning settling time, increase “Gr.0_ID00:Auto-Tuning response (ATRES)” setting value gradually. Decrease “Gr.0_ID00:Auto-Tuning response (ATRES)” setting value to reduce motor oscillation.

Manual tuning is recommended if motor performance is not sufficient using Auto Tuning function. Please refer manual M-E099GA0C2-190 how to implement manual tuning.

8.2 Magnetic pole position estimation

Model EGA driver requires Magnetic pole position estimation every time when power is turned on.

In case of situation described in below which may affect Magnetic pole position estimation, please adjust “Gr.B_ID01:Excitation Command Frequency setting (EMPFREQ)” and “Gr.B_ID02:Acceleration threshold (ACC)” with considering conditions of equipment.

Conditions which may affect Magnetic pole position estimation.

- Motor has external and/or unbalanced force.
- Low rigidity of equipment. (Base, Load, Installation)
- Excessive Load moment of inertia.
- Frequency setting value of “Gr.B_ID01:Excitation Command Frequency setting (EMPFREQ)” is close to resonance frequency of equipment.
- Motor combined with improper converter unit.

Parameter setting procedure to solve “Magnetic pole position estimation error”.

Adjust setting value of “Gr.B_ID01:Excitation Command Frequency setting (EMPFREQ)”

Adjust setting value of “Gr.B_ID02:Acceleration threshold (ACC)”.

Alarm code for "Magnetic pole position estimation error".

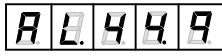

Driver condition code at alarm 9 : Implementing Magnetic pole position estimation

Alarm code 44 : Magnetic pole position estimation error

8.3 Homing

Motor does not incorporate home sensor. Homing must be operated by host equipment using external home sensor referring homing sequence and home sensor setting position described in below.

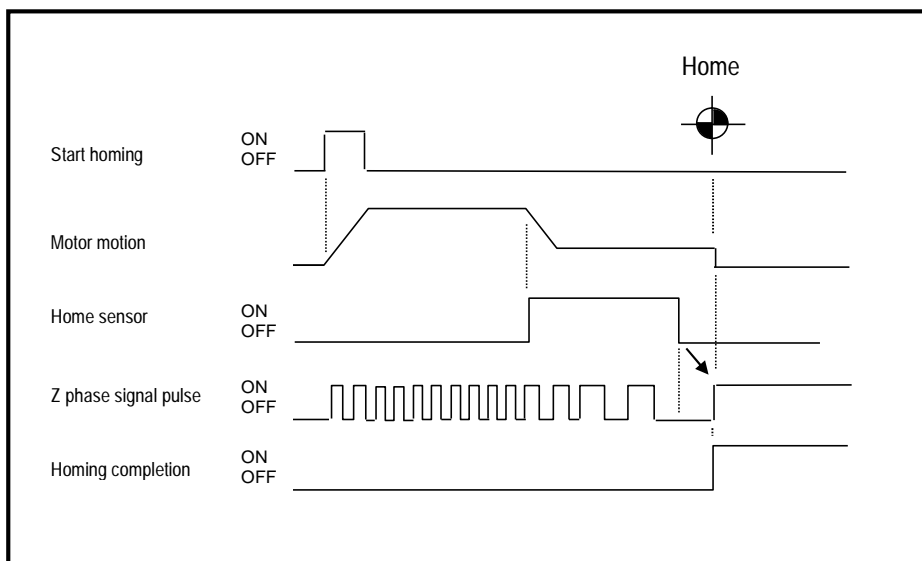

Example of homing sequence

To secure home position by detecting rise up of Z phase signal properly, turn off point of home sensor must be adjusted at the middle point between Z phase signal described in below. Adjust home sensor turn off position around 32767 [pulse] by monitoring motor position using "Monitor_ID80:Resolver sensor electric angle(RESANG)".

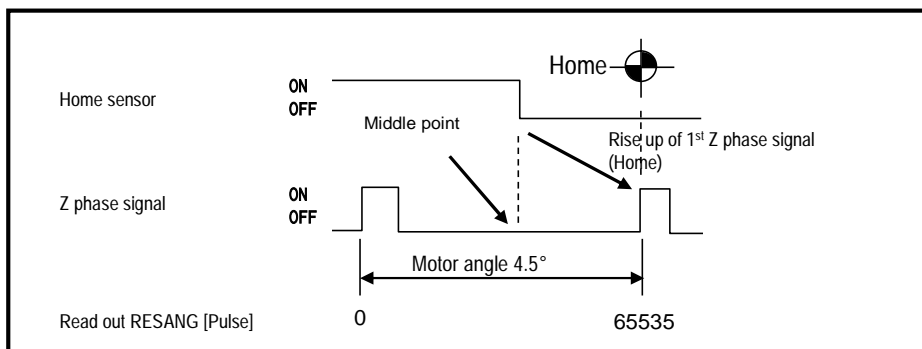

Home sensor turn off position

9. Related document

- Please refer manual M-E099GA0C2-191 about the detail of Parameters, Tuning procedure, Alarm and Optional parts.
- Please use application software "MEGATORQUE MOTOR SETUP" to Edit parameters, and Monitor signals. Refer HELP for instruction manual.

10. Major section and page number to refer in manual M-E099GA0C2-191

Item	Section	Page no.
Motor specifications	2	2-1
Specifications of driver		2-3
Specifications of converter		2-12
Motor installation	3	3-4
Set main circuit power input type as Single phase AC power	5	5-1
Motor and signal state at occurrence of alarm		5-12
Monitor Input / Output signal state		5-16
Parameters for tuning.		5-29
Servo Tuning functions and basic adjustment procedure	6	6-1
Set Load inertia moment		6-9
Manual tuning		6-13
Digital operator	7	7-1
List of warning and alarm	8	8-3
Trouble shooting when alarm activated		8-7
Optional parts	9	9-7
Install product in safety.	Safety precautions	~