

# TECHNICAL INSIGHT

A PUBLICATION OF NSK EUROPE

## Bearing designs and construction Two basic types for a wide range of applications

Bearings generally consist of two rings or discs, rolling elements and a cage. Depending on the direction of the main load, a distinction is made between two basic types: radial bearings and thrust bearings. Based on the kind of rolling elements used, they are also classified as ball bearings or roller bearings. Each bearing design has specific characteristics and is therefore suitable for certain purposes.

### 1. Radial bearings

#### Single-row deep-groove ball bearings

Deep-groove ball bearings are the most common type of bearing. These bearings predominantly absorb radial forces, but axial loads can be imposed in either direction to a limited extent. Other design features may include seals, shields and pressed steel cages. These bearings are particularly suitable for applications with very high speeds and low frictional losses.

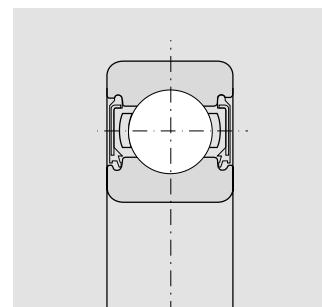

#### Self-aligning ball bearings

The outer ring of this type of bearing has a spherical raceway; the ball complement and inner ring are capable of self-alignment. This makes self-aligning ball bearings ideal when it is difficult to align the shaft and housing and when the shaft can deflect. Self-aligning ball bearings absorb radial and axial forces.

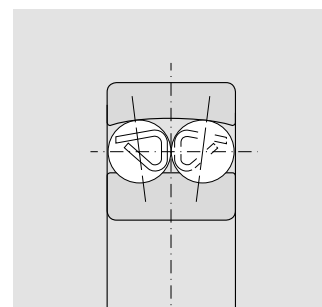

---

### Angular-contact ball bearings

In addition to radial forces, **single-row angular-contact ball bearings** are capable of taking high axial forces in one direction. The forces are transferred from one raceway to the other in the contact angle ( $\alpha$ ).

Various contact angles are available, but small contact angles are advantageous for high-speed operation.

**Double-row angular-contact ball bearings** consist of two single-row angular-contact ball bearings arranged back to back. They can absorb axial forces in either direction.

Four-point contact ball bearings are a **special type of angular-contact ball bearing** with a contact angle of  $\alpha = 35^\circ$ . They are separable because the inner ring consists of two parts. Four-point contact bearings have brass cages.

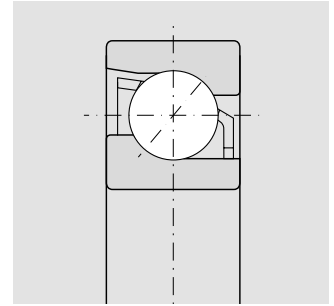

**Single-row angular-contact ball bearings:** when bearings are used in pairs, the clearance between them must be adjusted properly.

---

**Cylindrical roller bearings** are characterised by a high radial load capacity, which results from the linear contact between the rolling elements and the raceways. Some types can also take axial forces, depending on the design. Cylindrical roller bearings are separable.

**Double-row cylindrical roller bearings** have high radial rigidity. They are used for applications such as high-precision machine tools.

**Needle roller bearings** are a special kind of cylindrical roller bearing. They only absorb radial forces. These bearings have very long, thin rolling elements with a length three to ten times their diameter.

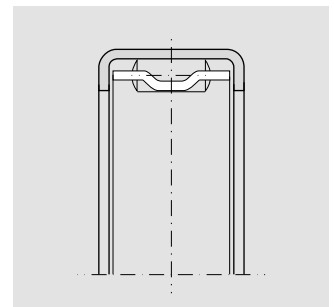
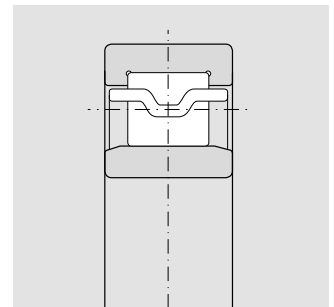

---

### Tapered roller bearings

Due to their contact angle ( $\alpha$ ), tapered roller bearings are capable of taking high radial and axial loads in one direction. These bearings are generally mounted in pairs to absorb axial forces in both directions.

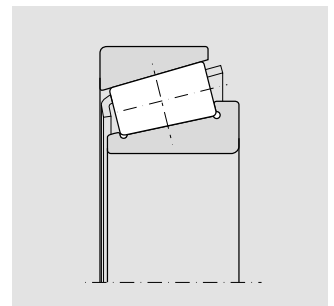

---

### Spherical roller bearings

Spherical roller bearings can be used to compensate for misalignment between the shaft and the housing because their outer ring has a spherical raceway. Spherical roller bearings can take high radial loads and medium axial loads.

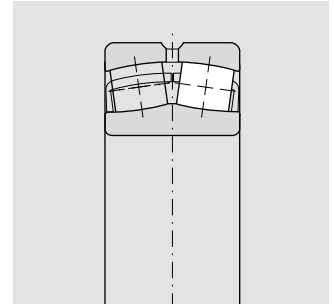

---

## 2. Thrust bearings

### Thrust ball bearings

**Single-direction thrust ball bearings** consist of two bearing washers with raceways for the balls. This design enables them to absorb purely axial forces.

**Double-direction thrust ball bearings** have three bearing washers. The middle one is attached to the shaft. Bearings of this kind can take axial forces in both directions.

**Spherical thrust roller bearings** are capable of taking very high axial loads and lower radial loads.

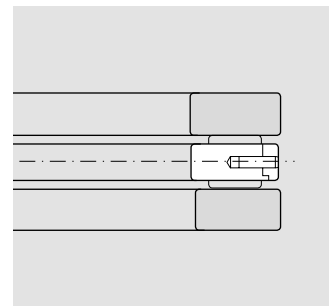

The shaft washer or inner ring is attached to the shaft, while the housing washer is attached to the housing.