

NSK Standard Ball Screws High Speed SS Model

NSK's high speed and low noise ball screws provide high-level performance for drive systems of industrial machines such as those used in manufacturing. A standard stock series assures quick delivery.

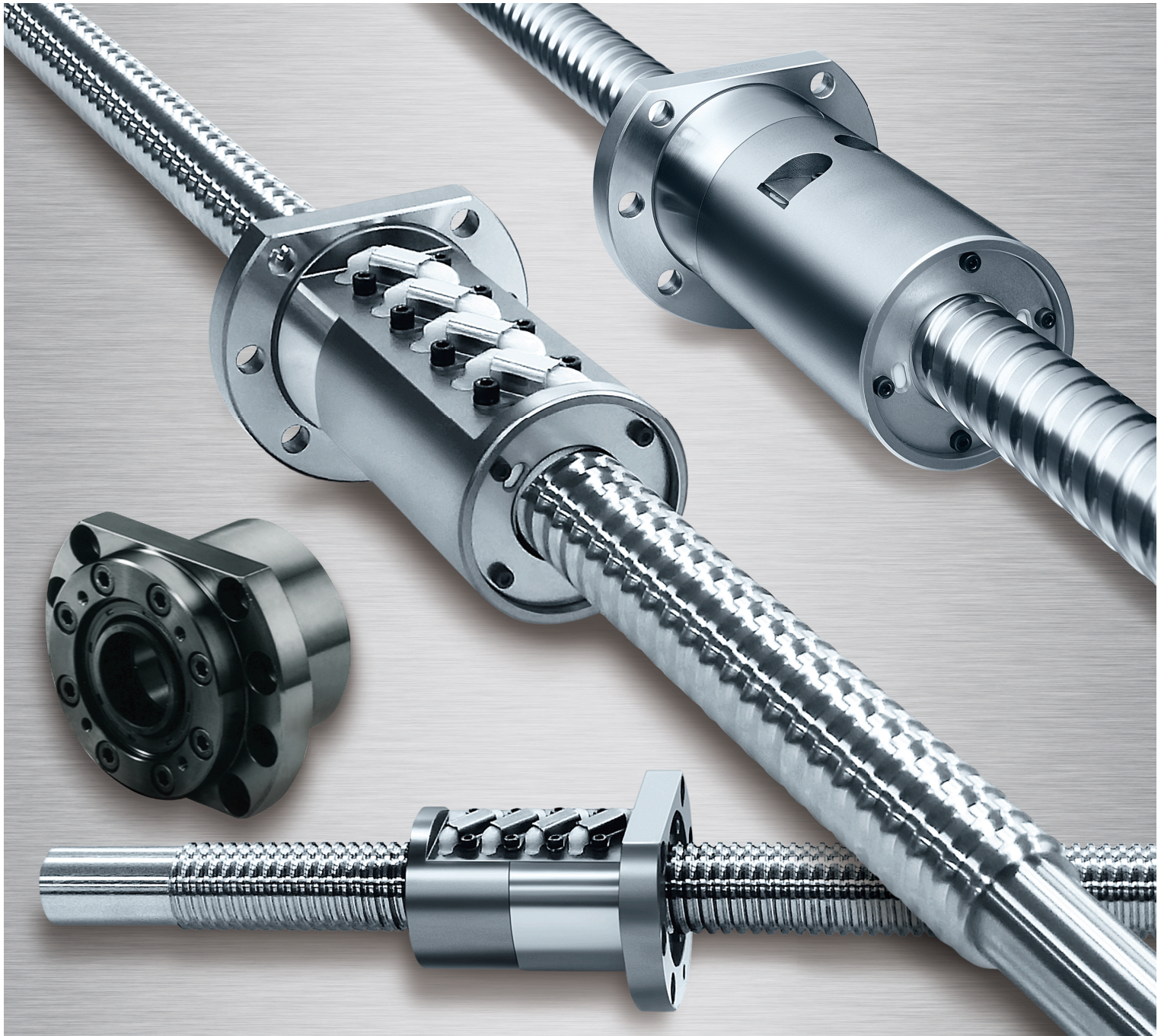

High Speed SS (HSS) Model Standard ball screws, high speed and low noise enable further performance improvements to be made.

The HMS and HMD Models, originally developed for machine tools, are an addition to NSK's lineup of standard ball screws. They have a wide range of applications, from general machines to high performance machines such as those requiring high speed and precision.

NSK's original recirculation system realized high speed and low noise. An optimum recirculation system has been adopted based on the lead.

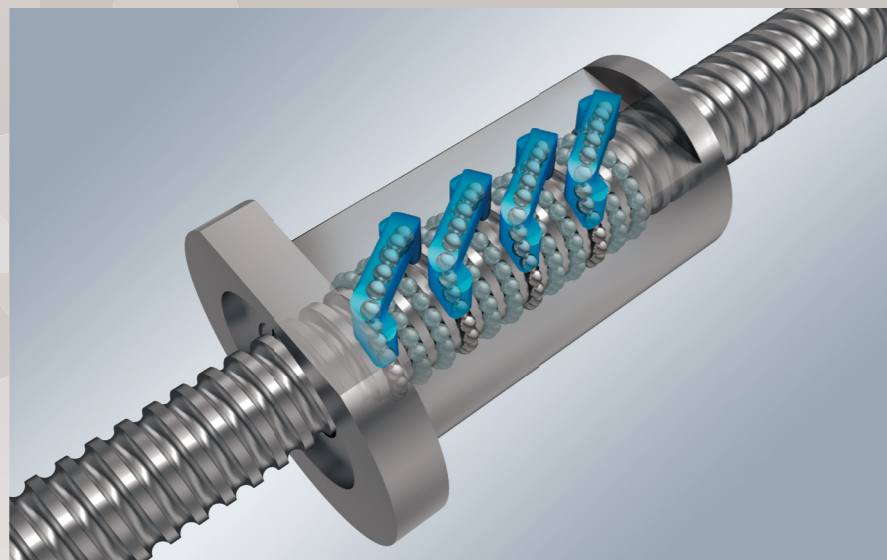

SRC recirculation system is suitable for fine screw leads.

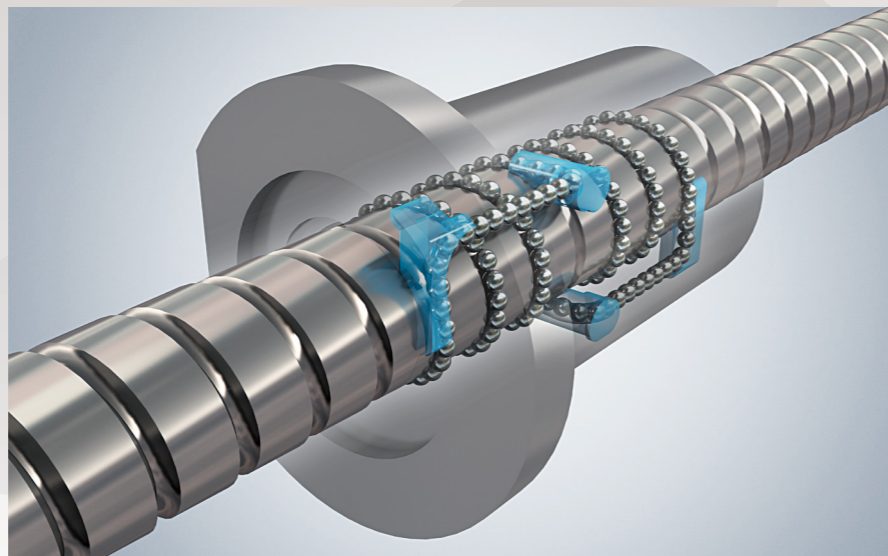

The end deflector and middle deflector recirculation system are suitable for medium leads.



Permissible rotational speed is more than double
d·n limit value: high speed of 160 000

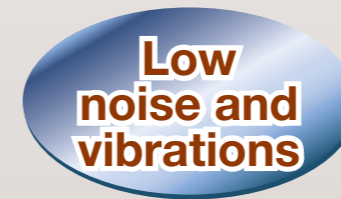

Noise level has been reduced by 50%: a reduction of 6 dB(A)
Vibration has been reduced drastically



Installation dimensions are the same as those of a conventional SS Model



Compact design created using offset preload system



Design flexibility has been improved by blank shaft end.
New support units are also provided for high speed operation.

High speed

The new recirculation system that utilizes NSK's high speed and low noise technology more than doubles the d·n value from 70 000 to 160 000. To extend the range of the lead to 20mm, high speed operation of over 60m/min. is possible.

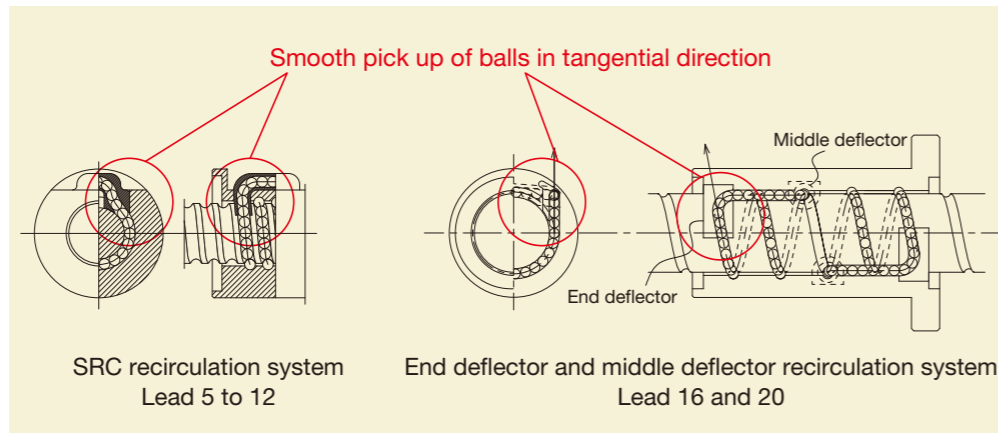

● Allowable feed speed of combinations of shaft diameter and lead.

Shaft diameter [mm] \ Lead [mm]	5	10	12	16	20
32	25m/min	50m/min			
40		40m/min	48m/min	64m/min	80m/min
45		35m/min			
50		32m/min	38m/min		

*Allowable speed needs to be calculated. See the permissible rotational speed in the dimensions table.

Low noise and vibrations

Compared to our conventional products, the average noise level has been reduced by more than 6 dB(A), reducing the number of colliding balls and recirculation parts thanks to high speed, low noise technology. The vibration level of the nut has also been reduced drastically.

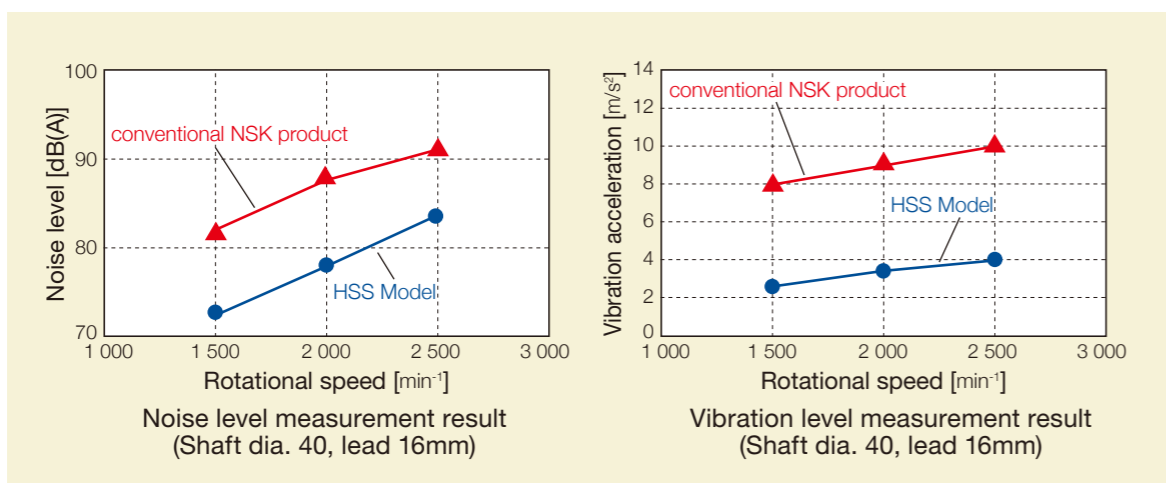

Interchangeability

Installation dimensions are the same as those of a conventional SS Model

Compact

By improving the nut manufacturing technology, highly precise screw manufacturing is possible with the long nut. Achieved high-level stiffness and high load capacity equivalent to that of double nut preload by changing the double nut preload to the offset preload of a single nut, and compact sized nut.

● **Seal**

Adopted thin seals axially and shorten nut length

Convenience

● **Optional configurations are possible for ball screw length as well as for the shaft end design**

The blank shaft ends can be customized according to customers' requests. See page 11 in NSK's recommended design when drawing up plans for a shaft end. The support units are available on pages 12-14 in the case of NSK's recommended design.

● **New support unit: For high speeds and heavy loads**

The support unit is applied for the thrust angular contact ball bearing, TAC series, with high precision and rigidity. NSK design is available attached to the support unit, which easily constitutes a system.

● **Oil supply**

2 oil holes, M6×1.0, are provided in the nut flange periphery and the end of the nut flange. A plug is standardly screwed into the periphery of the nut flange.

Ball screw specification

Accuracy grade	C5 of JIS B 1192 (1997)
Axial play Preload system	Axial play: 0 Offset preload (Z preload)
Thread direction	Right hand
Shaft end	Both shaft ends blank (Unhardened area: HRC 40 max.)

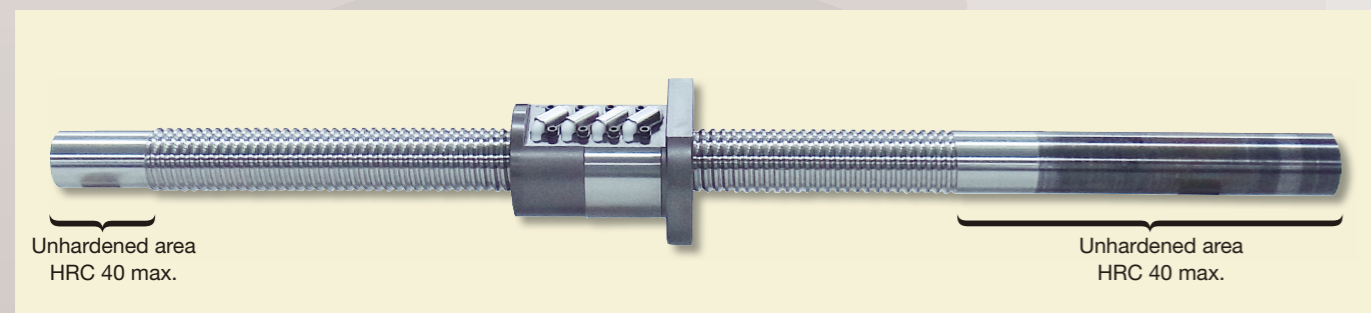

Reference No.

The reference number is an identification number or symbol used for each model. Specify the reference number when ordering, and thereafter, specify the shape of the end of the shaft indicated by NSK.

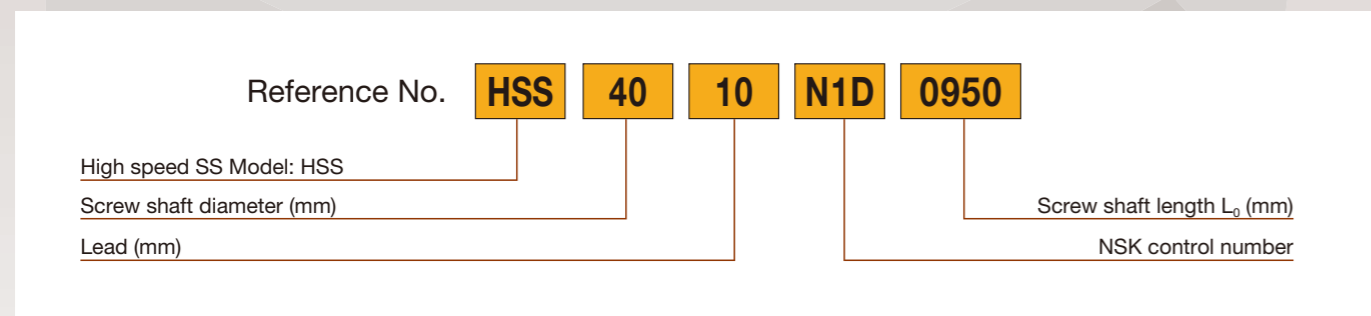

Precautions

◆ Design

1. One end of the screw shaft is cut through.
2. If a ball screw of which the left shaft end (opposite the driving side) is the shape \bar{I} , and if it is supported with the "fixed-fixed" supporting method, you should be aware that the operating life of support bearings may shorten due to thermal expansion of the screw shaft, depending on usage conditions. In this case, you should consider a structure that can accommodate thermal expansion of the screw shaft if necessary. Please consult with NSK for a detailed examination.
3. For general precautions concerning ball screws, please check NSK Catalog No.E3162 "Precision Machine Components".

◆ Usage

1. Instructions for shaft end processing
The high speed SS Model has a straight cut shaft end. Therefore, during actual use, the end of the shaft must be machined according to the customer's specifications. NSK recommends designated suppliers that offer quality assurances and precision guarantees. If any other supplier carries out processing, NSK will not provide a precision guarantee.
2. Service temperature environment of 60°C or less (at the nut outer temperature)
3. Only a rust preventive agent is applied at the time of delivery. Please apply lubricant, oil or grease before using.
4. The seals are installed on the end of the nut with the ball screw shaft. However, the ball screws should be provided with a dust cover to prevent debris such as dust and metal powder from entering.
5. If the nut accidentally comes off the screw shaft, please contact NSK.

Dimension: Lead 5, 10, and 12 Shaft screw dia.32, 40, 45 and 50

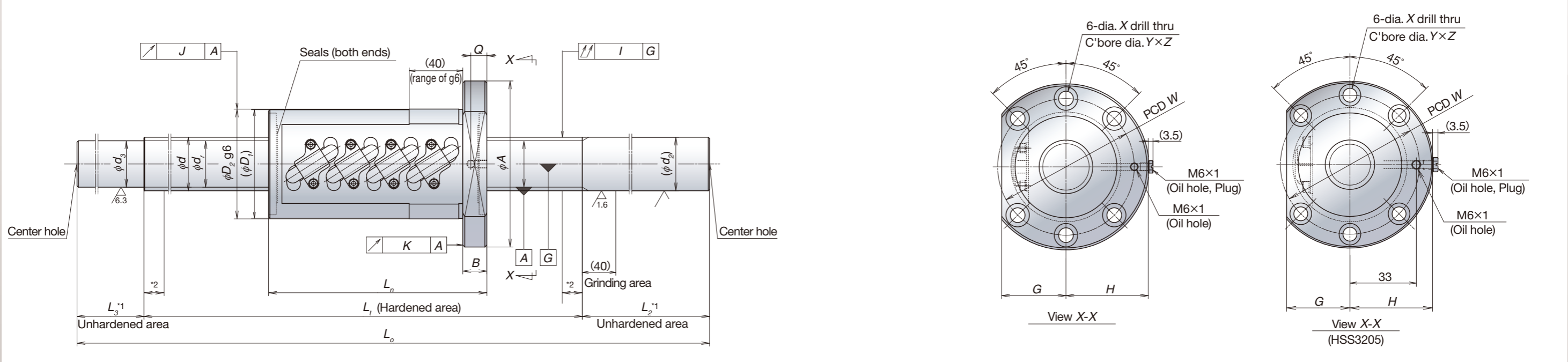

Unit: mm

Reference No.	Screw shaft dia. d	Lead ℓ	Root dia. dr	Effective balls turns x Circuits	Basic load ratings [N]		Preload [N]	Dynamic friction torque, median [N-cm]	Nut rigidity [N/μm]	Ball nut dimensions								Screw shaft dimension						Lead accuracy			Run-out		Mass [kg]	Permissible rotational speed [min ⁻¹]		Internal spatial volume of nut [cm ³]							
					Dynamic Ca	Static Coa				Diameter			Overall length Ln	Bolt hole		Oil hole Q	Threaded length Lt	Shaft end, right		Shaft end, left		Travel compensation T	Deviation ep	Variation Vp	Shaft straightness I	Radial run-out		Fixed-Free support		Fixed-Fixed support									
										D1	D2	A		G	H			B	W	X	Y					Z	d2				L2		d3	L3	L0	J	K		
																											Installation												
HSS3205N1D0650	32	5	29.2	2.5x2	21 800	56 000	920	17.0	840	57	58	85	32	42	13	89	71	6.6	11	6.5	8	400	200	29.2	100	1 250	-0.010	0.025	0.020	0.055	0.019	0.013	5.2	5 000	5 000				
600																						950											-0.014	0.030	0.023	0.065	7.0	5 000	5 000
900																						250											-0.022	0.040	0.027	0.080	8.7	5 000	5 000
1 150																						300											-0.028	0.046	0.030	0.100	10.5	3 500	4 700
1 450																						300											-0.035	0.054	0.035	0.130	12.2	2 200	2 900
HSS3210N1D0850	32	10	26.4	2.5x2	54 500	110 000	2 310	59.5	920	73	74	108	41	53.5	15	160	90	9	14	8.5	10	500	250	26.4	100	1 050	-0.012	0.027	0.020	0.065	0.019	0.013	8.9	5 000	5 000				
700																						100											-0.017	0.035	0.025	0.080	10.0	5 000	5 000
1 050																						300											-0.025	0.046	0.030	0.100	12.2	4 100	5 000
1 450																						300											-0.035	0.054	0.035	0.130	14.3	2 100	2 800
1 850																						300											-0.045	0.065	0.040	0.170	16.5	1 200	1 700
HSS4010N1D0950	40	10	34.4	2.5x2	61 200	137 000	2 600	74.5	1 090	81	82	124	47	61.5	18	163	102	11	17.5	11	12	600	250	34.4	100	1 450	-0.014	0.030	0.023	0.050	0.025	0.015	13.5	4 000	4 000				
1 050																						300											-0.025	0.046	0.030	0.070	17.9	4 000	4 000
1 600																						350											-0.039	0.054	0.035	0.110	23.5	2 200	3 000
2 400																						350											-0.058	0.077	0.046	0.140	30.5	900	1 300
1 050																						300											-0.025	0.046	0.030	0.070	19.1	4 000	4 000
HSS4012N1D2100	40	12	34.1	2.5x2	71 700	154 000	3 050	96.0	1 110	85	86	128	48	63.5	18	187	106	11	17.5	11	12	1 600	350	34.1	150	2 100	-0.039	0.054	0.035	0.110	0.025	0.015	24.8	2 200	3 000				
2 400																						350											-0.058	0.077	0.046	0.140	31.8	900	1 300
1 050																						300											-0.025	0.046	0.030	0.070	19.1	4 000	4 000
HSS4510N1D1450	45	10	39.4	2.5x2	65 800	157 000	2 710	82.0	1 210	87	88	132	50	65.5	18	163	110	11	17.5	11	12	1 600	350	39.4	150	2 100	-0.039	0.054	0.035	0.110	0.025	0.015	29.2	2 500	3 400				
2 400																						350											-0.058	0.077	0.046	0.140	38.2	1 100	1 500
1 050																						300											-0.025	0.046	0.030	0.070	22.0	3 500	3 500
HSS5010N1D1850	50	10	44.4	2.5x2	68 100	174 000	2 880	92.0	1 320	92	93	135	51	67	18	163	113	11	17.5	11	12	1 450	300	44.4	100	1 850	-0.035	0.054	0.035	0.090	0.025	0.015	31.9	3 200	3 200				
1 850																						350											-0.045	0.065	0.040	0.110	38.8	2 100	2 900
2 400																						350											-0.058	0.077	0.046	0.140	46.5	1 200	1 700
1 050																						300											-0.025	0.046	0.030	0.070	28.5	3 200	3 200
1 600																						350											-0.039	0.054	0.035	0.110	37.3	2 800	3 200
HSS5012N1D2900	50	12	43.2	2.5x2	91 500	218 000	3 880	136.5	1 360	99	100	146	55	72.5	22	193	122	14	20	13	12	2 400	350	43.2	150	2 900	-0.058	0.077	0.046	0.140	0.025	0.015	48.2	1 200	1 600				
1 050																						300											-0.025	0.046	0.030	0.070	28.5	3 200	3 200

Notes: ● NSK support units are recommended. Refer to Page 12 to 14 for details.

● Only a rust preventive agent is applied at the time of delivery. Please apply lubricant, oil or grease before use.

● Nut rigidity: Values in the table are theoretical values obtained from the elastic deformation between ball grooves with preload and balls.

● Permissible rotational speed: Calculated values obtained from the critical speed between the threaded length and NSK's recommended shaft end design.

● *1: Unhardened area: HRC 40 max.

● *2: Imperfect hardened areas for one lead exists on both ends of a screw. Exercise care when stroke setting

Dimension: Lead16, 20 Shaft screw dia.40

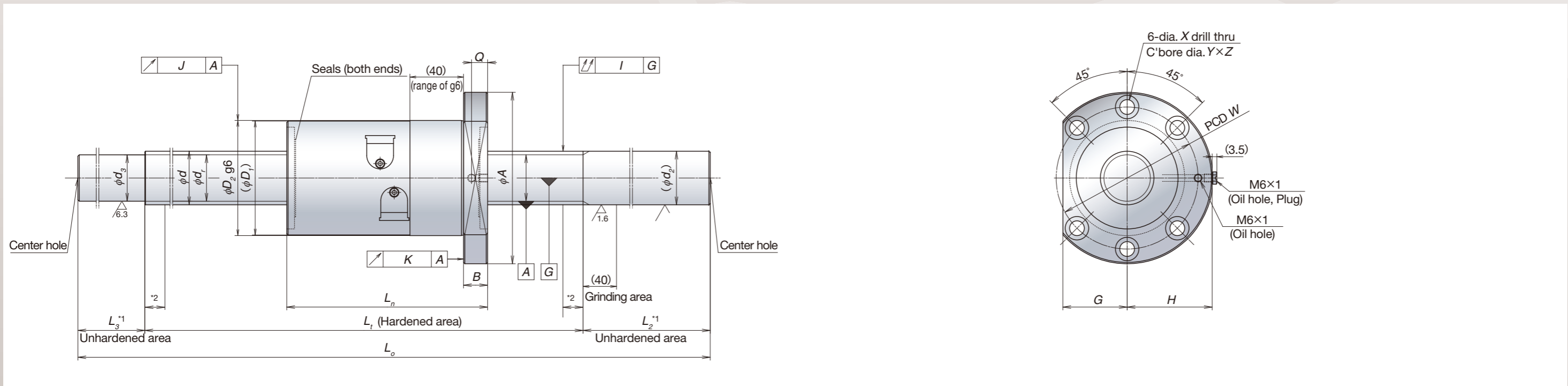

Unit: mm

Reference No.	Screw shaft dia. d	Lead l	Root dia. dr	Effective balls turns x Circuits	Basic load ratings [N]		Preload [N]	Dynamic friction torque, median [N·cm]	Nut rigidity [N/μm]	Ball nut dimensions							Screw shaft dimension					Lead accuracy			Run-out		Mass [kg]	Permissible rotational speed [min ⁻¹]		Internal spatial volume of nut [cm ³]											
					Dynamic Ca	Static Coa				Diameter		Flange		Overall length Ln	Bolt hole				Oil hole Q	Threaded length Lt	Shaft end, right		Shaft end, left		Overall length L0	Travel compensation T		Deviation ep	Variation Vv		Shaft straightness I	Radial run-out		Mass [kg]	Permissible rotational speed [min ⁻¹]						
										D1	D2	A	G		H	B	W	X			Y	Z	d2	L2								d3	L3		J	K	Installation	Fixed-Fixed support	Fixed-Fixed support		
HSS4016N1D1450	40	16	34.1	3.7x1	66 900	131 000	2 850	104.0	970	85	86	128	48	63.5	18	160	106	11	17.5	11	11	1 050	40	300	34.1	100	1 450	-0.025	0.046	0.030	0.070	0.025	0.015	19.2	4 000	4 000	40				
1 600																						350		150		2 100		-0.039							0.054	0.035		0.110	25.0	2 200	3 000
2 400																						350		150		2 900		-0.058							0.077	0.046		0.140	32.2	900	1 300
HSS4016N1D2900	40	16	34.1	3.7x1	66 900	131 000	2 850	104.0	970	85	86	128	48	63.5	18	160	106	11	17.5	11	11	1 050	40	300	34.1	100	1 450	-0.025	0.046	0.030	0.070	0.025	0.015	20.3	4 000	4 000	47				
1 600																						350		150		2 100		-0.039							0.054	0.035		0.110	26.2	2 200	3 000
2 400																						350		150		2 900		-0.058							0.077	0.046		0.140	33.5	900	1 300
HSS4020N1D1450	40	20	34.1	3.7x1	66 500	131 000	2 850	116.5	960	85	86	128	48	63.5	18	192	106	11	17.5	11	11	1 050	40	300	34.1	100	1 450	-0.025	0.046	0.030	0.070	0.025	0.015	20.3	4 000	4 000	47				
1 600																						350		150		2 100		-0.039							0.054	0.035		0.110	26.2	2 200	3 000
2 400																						350		150		2 900		-0.058							0.077	0.046		0.140	33.5	900	1 300

- Notes:
- NSK support units are recommended. Refer to Page 12 to 14 for details.
 - Only a rust preventive agent is applied at the time of delivery. Please apply lubricant, oil or grease before use.
 - Nut rigidity: Values in the table are theoretical values obtained from the elastic deformation between ball grooves with preload and balls.

- Permissible rotational speed: Calculated values obtained from the critical speed between the threaded length and NSK's recommended shaft end design.
- *1: Unhardened area: HRC 40 max.
- *2: Imperfect hardened areas for one lead exists on both ends of a screw. Exercise care when stroke setting

Dimension: Recommendation for shaft end design

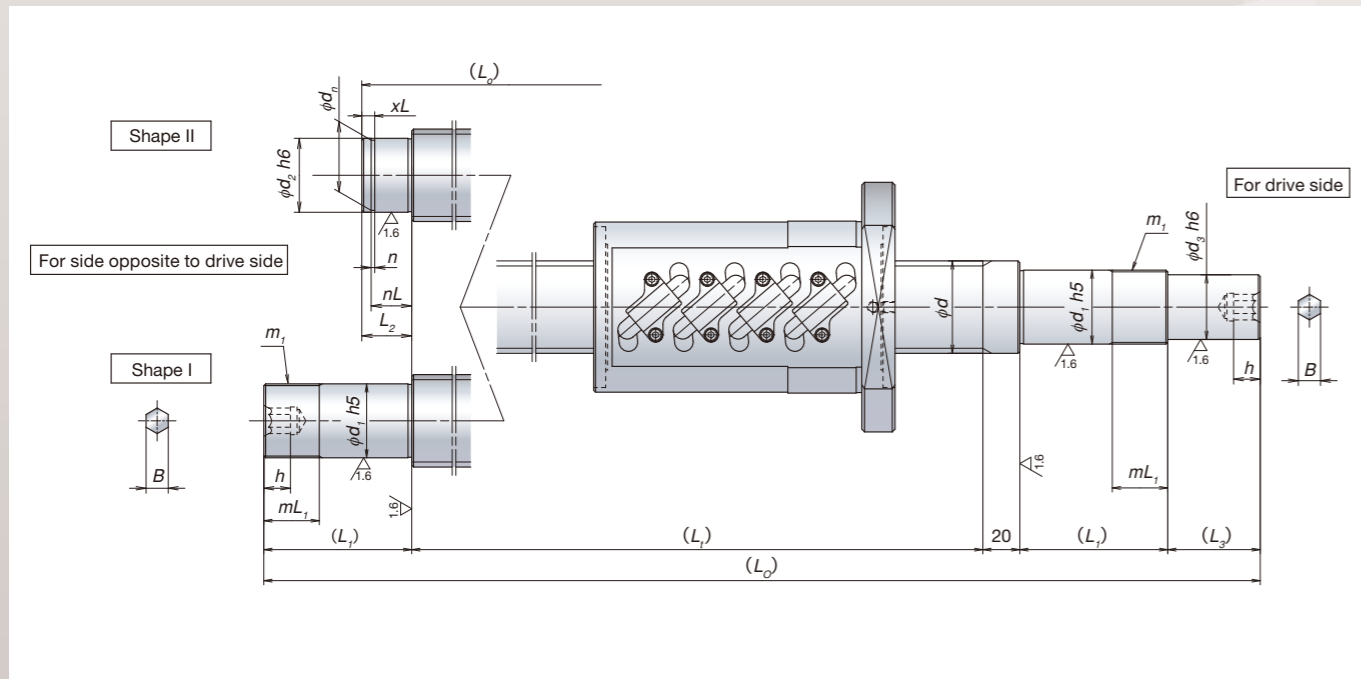

For drive side: Recommendation for shaft end design

Unit: mm

Screw shaft diameter	Bearing installation		Thread screw		Support unit	Parts installation		Shaft length				
	Diameter	Length	Screw size	Length		Diameter	Length	Screw length	Shaft overall length	Shaft end hexagon hole		
<i>d</i>	<i>d₁</i>	<i>L₁</i>	<i>m₁</i>	<i>mL₁</i>		<i>d₃</i>	<i>L₃</i>	<i>L_t</i>	<i>L_o</i>	<i>B</i>	<i>h</i>	
32	25	89	M25×1.5	26	WBK25DF-31H	20	51	max 1 850	max 2 250	8 ^{+0.2} ₀	10	
		104										WBK25DFD-31H
40	30	89	M30×1.5	26	WBK30DF-31H	25	61	max 2 400	max 2 900	10 ^{+0.2} ₀	12	
		104										WBK30DFD-31H
45	35	92	M35×1.5	30	WBK35DF-31H	30	63	max 2 400	max 2 900	12 ^{+0.3} ₀	14	
		107										WBK35DFD-31H
		122										WBK35DFF-31H
50	40	92	M40×1.5	30	WBK40DF-31H	35	78	max 2 400	max 2 900	14 ^{+0.3} ₀	18	
		107										WBK40DFD-31H
		122										WBK40DFF-31H

For side opposite to drive side: Recommendation for shaft end design

Unit: mm

Screw shaft diameter	Shape	Bearing installation		Thread screw		Snap ring ditch			Support unit (Bearing model)
		Diameter	Length	Screw size	Length	Width	Ditch diameter	Ditch location	
<i>d</i>		<i>d₂</i>	<i>L₂</i>	<i>m₂</i>	<i>mL₂</i>	<i>n</i>	<i>d_n</i>	<i>nL (xL)</i>	
32	I	*		-	-	-	-	-	*
	II	25	20	-	-	1.35 ^{+0.14} ₀	23.9 ^{-0.21} ₀	16.35 (5)	(6205)
40	I	*		-	-	-	-	-	*
	II	30	22	-	-	1.75 ^{+0.14} ₀	28.6 ^{-0.21} ₀	17.75 (6)	(6206)
45	I	*		-	-	-	-	-	*
	II	35	23	-	-	1.75 ^{+0.14} ₀	33 ^{-0.25} ₀	18.75 (6)	(6207)
50	I	*		-	-	-	-	-	*
	II	40	25	-	-	1.95 ^{+0.14} ₀	38 ^{-0.25} ₀	19.95 (7)	(6208)

- The dimensions of the drawing can be flexibly set within limits.
- The support unit is available with a recommended design.
- *: The same as that of the drive side.

New support unit (For high speed and heavy load)



Heat generation has been reduced via adoption of a low preload type bearing. Along with speedup of the ball screw, permissible rotational speed have been improved.

The new support units are assembled with the thrust angular contact ball bearings, TAC series, which are a high precision, high rigidity, high speed type with the most suitable function and structure. The bearing combination comes in three types as shown in the figure below

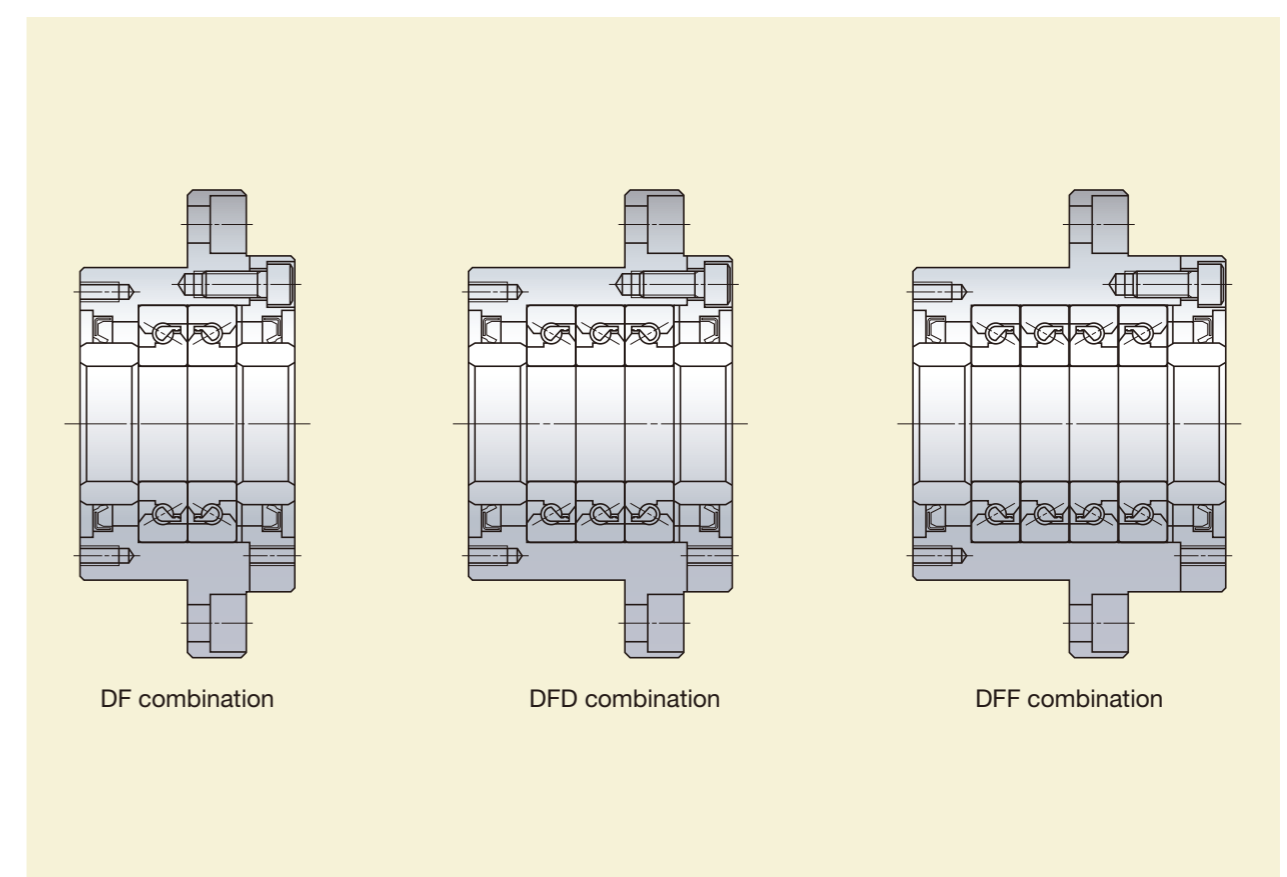

Support unit reference No.

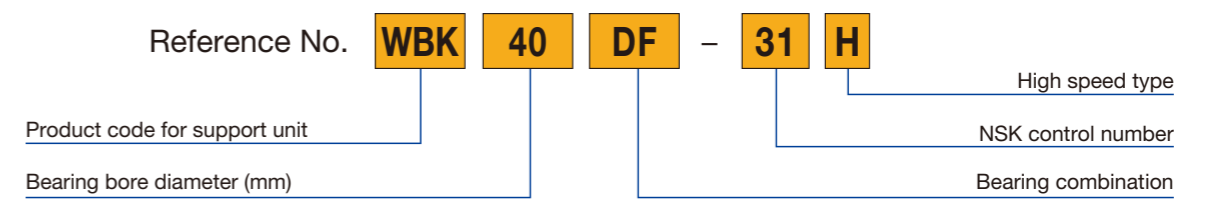

Dimension: Support unit

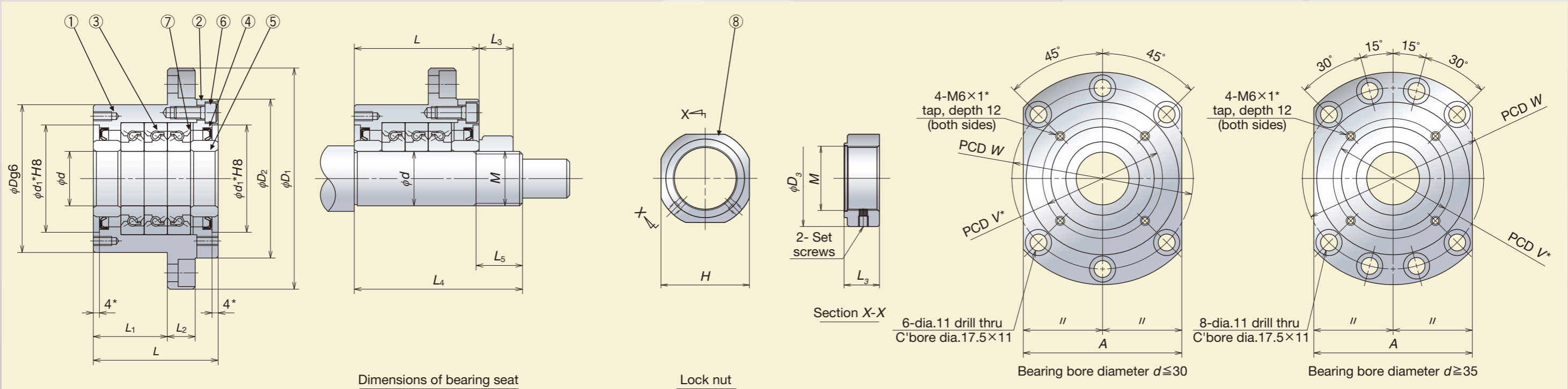

Unit: mm

Reference No.	Support unit											Basic dynamic load rating [N]	Permissible axial load [N]	Preload [N]	Axial rigidity [N/μm]	Maximum starting torque [N-cm]	Lock nut				Bearing seat for unit			Permissible rotational speed [min ⁻¹]	Mass [kg]		
	d	D	D ₁	D ₂	L	L ₁	L ₂	A	W	d ₁ *	V*						Length		Installation torque [N-cm]	d	L ₄	L ₅					
																	M	H					D ₃			L ₃	
WBK25DF-31H	25	85	130	90	66	33	18	100	110	57	70	29 900	40 500	2 280	850	21	M25×1.5	41	45	20	8 500	25	89	26	5 200	3.1	
WBK25DFD-31H					81	48						48 500 (29 900)	81 500 (40 500)	3 100	1 250	28							104			104	3.4
WBK30DF-31H	30	85	130	90	66	33	18	100	110	57	70	30 500	43 000	2 400	890	23	M30×1.5	46	50	20	10 100	30	89	26	4 900	3.0	
WBK30DFD-31H					81	48						50 000 (30 500)	86 000 (43 000)	3 260	1 310	30							104			104	3.3
WBK35DF-31H	35	95	142	102	66	33	18	106	121	69	80	32 500	50 000	2 750	1 030	27	M35×1.5	50	55	22	13 800	35	92	30	4 100	3.4	
WBK35DFD-31H					81	48						53 000 (32 500)	100 000 (50 000)	3 740	1 500	34							107			107	4.3
WBK35DFF-31H					96	48						53 000	100 000	5 490	2 060	43							122			122	5.0
WBK40DF-31H	40	95	142	102	66	33	18	106	121	69	80	33 500	52 000	2 860	1 080	28	M40×1.5	55	60	22	15 500	40	92	30	4 100	3.6	
WBK40DFD-31H					81	48						54 000 (33 500)	104 000 (52 000)	3 900	1 590	36							107			107	4.2
WBK40DFF-31H					96	48						54 000	104 000	5 730	2 150	46							122			122	4.7

- Notes:
- Rigidity: Values in the table are theoretical and obtained from the elastic deformation between ball groove and balls.
 - Starting torque indicates torque due to the preload of the bearing. It does not include seal torque.
 - h5 class of the fits tolerance is recommended.
 - Pilot diameter and tapped screws marked with "*", are used for seal unit installation for NSK standard hollow shaft ball screws. They can also be used for the dust cover and damper installation.
 - Grease is packed into bearings. It is not necessary to apply grease before use.
 - Installation torque of a set screw 490[N-cm] (Reference value)
 - The locknut has been designed to stay fastened, but it may come loose if a machine has strong vibrations. Apply construction adhesive as necessary.
 - Allowable axial load is 0.7 times of the permissible axial load in the dimension table.
 - Values in parentheses of basic dynamic load rating and permissible axial load are the values when axial load is applied in a line.
 - Contact NSK if the rotational speed is 50 min⁻¹ and below.

Parts list

Parts No.	Part Name	Quantity
①	Housing	1
②	Retaining Cover	1
③	High accuracy thrust angular contact ball bearing	One set
④	Dust seal	2
⑤	Collar	2
⑥	Preload bolt	6 or 8
⑦	Shim	One set
⑧	Lock nut	1

- NSK support units are precisely preloaded and adjusted. Do not disassemble components ①, ②, ③, ④, ⑥ or ⑦.
- Lock nut ⑧ has been exclusively prepared for ball screws. The end surface of the nut is positioned precisely perpendicular to the V thread. Secure the lock nut using a set screw.

Worldwide Sales Offices

P: Phone ☆: Head Office

NSK LTD. HEADQUARTERS, TOKYO JAPAN

INDUSTRIAL MACHINERY BUSINESS DIVISION-HEADQUARTERS P: +81-3-3779-7227
 AUTOMOTIVE BUSINESS DIVISION-HEADQUARTERS P: +81-3-3779-7189

Africa

South Africa:

NSK SOUTH AFRICA (PTY) LTD.
 SANDTON P: +27-011-458-3600

Asia and Oceania

Australia:

NSK AUSTRALIA PTY. LTD.
 MELBOURNE ☆ P: +61-3-9765-4400
 SYDNEY P: +61-2-9839-2300
 BRISBANE P: +61-7-3347-2600
 PERTH P: +61-8-9256-5000

New Zealand:

NSK NEW ZEALAND LTD.
 AUCKLAND P: +64-9-276-4992

China:

NSK (SHANGHAI) TRADING CO., LTD.
 JIANGSU ☆ P: +86-512-5796-3000

NSK (CHINA) INVESTMENT CO., LTD.

JIANGSU ☆ P: +86-512-5796-3000
 BEIJING P: +86-10-6590-8161
 TIAN JIN P: +86-22-8319-5030
 CHANGCHUN P: +86-431-8898-8682
 SHENYANG P: +86-24-2550-5017
 DALIAN P: +86-411-8800-8168
 NANJING P: +86-25-8472-6671
 FUZHOU P: +86-591-8380-1030
 WUHAN P: +86-27-8556-9630
 QINGDAO P: +86-532-5568-3877
 GUANGZHOU P: +86-20-3817-7800
 CHANGSHA P: +86-731-8571-3100
 LUOYANG P: +86-379-6069-6188
 XI'AN P: +86-29-8765-1896
 CHONGQING P: +86-23-6806-5310
 CHENGDU P: +86-28-8528-3680

NSK CHINA SALES CO., LTD.

JIANGSU ☆ P: +86-512-5796-3000

NSK HONG KONG LTD.

HONG KONG ☆ P: +852-2739-9933
 SHENZHEN P: +86-755-25904886

Taiwan:

TAIWAN NSK PRECISION CO., LTD.
 TAIPEI ☆ P: +886-2-2772-3355
 TAICHUNG P: +886-4-2708-3393
 TAINAN P: +886-6-215-6058

India:

NSK BEARINGS INDIA PRIVATE LTD.
 CHENNAI ☆ P: +91-44-28479600
 GURGAON P: +91-124-4838000
 MUMBAI P: +91-22-28387787
 JAMSHEDPUR P: +91-657-2421144

Indonesia:

PT. NSK INDONESIA
 JAKARTA P: +62-21-252-3458

Korea:

NSK KOREA CO., LTD.
 SEOUL P: +82-2-3287-0300

Malaysia:

NSK BEARINGS (MALAYSIA) SDN.BHD.
 SHAH ALAM ☆ P: +60-3-7803-8859
 PRAI P: +60-4-3902275
 JOHOR BAHRU P: +60-7-3546290
 IPOH P: +60-5-2555000

Philippines:

NSK REPRESENTATIVE OFFICE
 MANILA P: +63-2-893-9543

Singapore:

NSK INTERNATIONAL (SINGAPORE) PTE LTD.
 SINGAPORE P: +65-6496-8000

Thailand:

NSK BEARINGS (THAILAND) CO., LTD.
 BANGKOK P: +66-2320-2555

Vietnam:

NSK VIETNAM CO., LTD.
 HANOI P: +84-24-3955-0159
NSK REPRESENTATIVE OFFICE
 HO CHI MINH CITY P: +84-28-3822-7907

Europe

United Kingdom:

NSK EUROPE LTD. (EUROPEAN HEADQUARTERS)
 MAIDENHEAD P: +44-1628-509-800

NSK UK LTD.

NEWARK P: +44-1636-605-123

France:

NSK FRANCE S.A.S.
 PARIS P: +33-1-30-57-39-39

Germany:

NSK DEUTSCHLAND GMBH
 DUSSELDORF ☆ P: +49-2102-4810
 STUTTGART P: +49-711-79082-0
 WOLFSBURG P: +49-5361-27647-10

Italy:

NSK ITALIA S.P.A.
 MILANO P: +39-299-5191

Netherlands:

NSK EUROPEAN DISTRIBUTION CENTRE B.V.
 TILBURG P: +31-13-4647647

Poland:

NSK POLSKA SP.Z O.O.
 WARSAW P: +48-22-645-1525

Spain:

NSK SPAIN S.A.
 BARCELONA P: +34-93-289-2763

Turkey:

NSK RULMANLARI ORTA DOGU TIC. LTD. STI.
 ISTANBUL P: +90-216-5000-675

United Arab Emirates:

NSK BEARINGS GULF TRADING CO.
 DUBAI P: +971-(0)4-804-8200

North and South America

United States of America:

NSK AMERICAS, INC. (AMERICAN HEADQUARTERS)
 ANN ARBOR P: +1-734-913-7500

NSK CORPORATION

ANN ARBOR P: +1-734-913-7500

NSK PRECISION AMERICA, INC.

FRANKLIN ☆ P: +1-317-738-5000
 SAN JOSE P: +1-408-944-9400

NSK LATIN AMERICA, INC.

MIAMI P: +1-305-477-0605

Canada:

NSK CANADA INC.
 TORONTO ☆ P: +1-888-603-7667
 MONTREAL P: +1-514-633-1220

Argentina:

NSK ARGENTINA SRL
 BUENOS AIRES P: +54-11-4704-5100

Brazil:

NSK BRASIL LTDA.
 SUZANO ☆ P: +55-11-4744-2500
 JOINVILLE P: +55-47-3422-2239

Peru:

NSK PERU S.A.C.
 LIMA P: +51-493-4385

Mexico:

NSK RODAMIENTOS MEXICANA, S.A. DE C.V.
 SILAO, GUANAJUATO P: +52-472-500-9500

< As of July 2022 >

For the latest information, please refer to the NSK website.

www.nsk.com

Every care has been taken to ensure the accuracy of data in this publication, but NSK Ltd. accepts no liability for any loss or damage incurred from errors or omissions. As we pursue continuous improvement, all content (text, images, product appearances, specifications, etc.) contained in this publication is subject to change without notice. Unauthorized copying and/or use of the contents of this publication is strictly prohibited. Please investigate and follow the latest product export laws, regulations, and permit procedures when exporting to other countries.

For more information about NSK products, please contact: _____

