



ROLL NECK BEARING MANUAL

HANDLING AND INSTALLATION INSTRUCTIONS



STAY IN MOTION. STAY IN CONTROL.

As one of the world's leading manufacturers of rolling bearings, linear technology components and steering systems, we can be found on almost every continent – with production facilities, sales offices and technology centres – because our customers appreciate short decision-making channels, prompt deliveries and local service.



The NSK company

NSK commenced operations as the first Japanese manufacturer of rolling bearings back in 1916. Ever since, we have been continuously expanding and improving not only our product portfolio but also our range of services for various industrial sectors. In this context, we develop technologies in the fields of rolling bearings, linear systems, components for the automotive industry and mechatronic systems. Our research and production facilities in Europe, Americas and Asia are linked together in a global technology network. Here

we concentrate not only on the development of new technologies, but also on the continuous optimisation of quality – at every process stage.

Among other things, our research activities include product design, simulation applications using a variety of analytical systems and the development of different steels and lubricants for rolling bearings.

Partnership based on trust – and trust based on quality

Total Quality by NSK: The synergies of our global network of NSK Technology Centres. Just one example of how we meet our requirements for high quality.

NSK is one of the leading companies with a long tradition in patent applications for machine parts. In our worldwide research centres, we not only concentrate on the development of new technologies, but also on the continual improvement of quality based on the integrated technology platform of

tribology, material technology, analysis and mechatronics.
More about NSK at www.nsk-europe.com or call us on +44 (0)1636 605123



Contents

1. Features, Part Name, and Marking by Bearing Type

1.1 Four-row tapered roller bearing, KV (TQO)	6
1.2 Sealed-Clean four-row tapered roller bearing, KVS.....	7
1.3 Four-row cylindrical roller bearing, RV and RVK	8
1.4 Double-cone tapered roller bearing, KDH, KH (TDI)	9
1.5 Double-direction tapered roller thrust bearing, TFD.....	10

2. Cautions for Handling

2.1 Before assembling.....	11
2.2 Required Tools	11

3. Bearing Assembling Procedure

3.1 Four-row tapered roller bearing, KV (TQO).....	12
3.1.1 Assembling procedure.....	12
3.1.2 After assembly	12
3.1.3 Handling of tapered bore four-row tapered roller bearing, KWK (TQIT)	14
3.2 Sealed-Clean four-row tapered roller bearing, KVS	16
3.2.1 Assembling the bearing	16
3.2.2 After the bearing is assembled.....	17
3.2.3 Lifting tool precautions.....	18
3.2.4 Cautions for the assembly of the bearing in the chock.....	18
3.2.5 Assembly of the bearing in the chock.....	18
3.2.6 Handling the lifting tool (example).....	18
3.2.7 Cautions for the assembly of the roll and chock assembly with the bearing.....	18
3.3 Four-row cylindrical roller bearing, RV.....	20
3.3.1 Assembling the bearing into the chock	20
3.3.2 How to install and remove the inner ring	22
3.3.3 Installation onto the roll neck	22
3.3.4 Co-grinding of the roll barrel and inner ring raceway	22
3.4 Double-cone tapered roller bearing, KDH, KH (TDI).....	24
3.4.1 Assembling the bearing into the chock	24
3.4.2 Clearance adjustment of the bearing using preload springs.....	24
3.5 Double-direction tapered roller thrust bearing, TFD	26
3.5.1 Assembling the bearing	26
3.5.2 Adjusting the bearing holder lid during assembly.....	26



4. Inspection Items

4.1 General inspection items	28
4.2 Inspection of a sealed bearing	29
4.3 Inspection of parts other than bearing	29
4.4 Bearing service record	29

5. Lubrication

5.1 Purpose and effect	32
5.2 Lubrication method	32
5.2.1 Grease lubrication	32
5.2.2 Oil lubrication	33
(1) Forced oil circulation lubrication	33
(2) Oil mist lubrication method	34
(3) Oil-air lubrication	35

1. Features, Part Name, and Marking by Bearing Type

1.1 Four-row tapered roller bearing, KV (TQ0)

The roll neck bearing used in a rolling mill is limited in its dimensions by the roll neck diameter and minimum roll diameter. The four-row tapered roller bearing is so designed that its load rating may be as large as possible within this limited space. This type of bearing consists of two sets of cone assemblies, three cups and two cup spacers. To facilitate installation and removal of the roll and chock, this type of bearing is loose-fitted to the roll neck. Accordingly, lubrication to the fit surface is essential to prevent scoring between the roll neck and bearing bore due to creep. To prevent wear and seizure of cone and cone spacer, oil slots are provided on one side of the cone and both sides of cone spacer. Double-row cup and cup spacers are provided with oil holes and oil grooves to supply the lubricant.

Hair cracks caused in the cone side surfaces by creep may lead to cracks in the cone. To prevent such cracking and to enhance the shock resistance of a bearing, the bearing rings are made from carburized steel usually. The cage is designed as a window type or pin type.

Name and Marking of parts

In addition to the bearing number, as shown in Fig. 1.1, the bearing is provided with a serial number that is common to one set of bearings and matching symbols indicating the combination order. The serial number is used to prevent mismatching during combination of bearings while matching symbols show the proper position of each part within a bearing. A wrong combination of these parts may cause an excessively small bearing clearance, resulting in seizure. On the other hand, an excessively large clearance due to a wrong combination may cause reduction of the load zone, resulting in a shorter fatigue life.

The cup of a bearing is provided with load position numbers at four equally-divided points around the circumference. (These numbers are provided on the cone if the cup rotates.) So that the bearing life can be extended, each time the bearing is reassembled after disassembly and cleaning, shift the load position numbers by 90° to change the load zone.

Fig. 1.1 Name of parts and marking examples (Four-row tapered roller bearing)

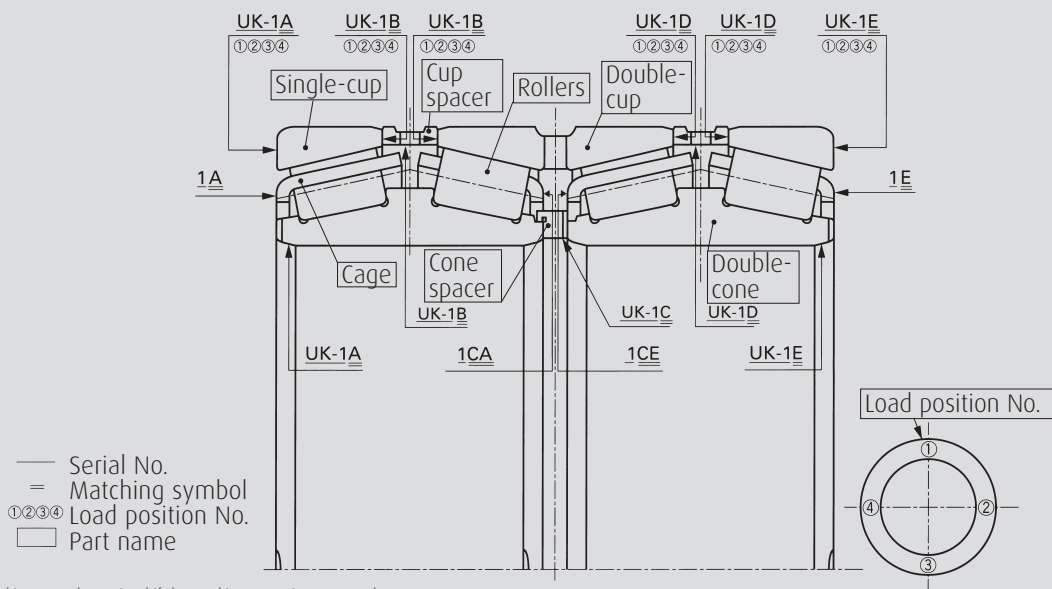

1.2 Sealed-Clean four-row tapered roller bearing, KVS

Sealed-clean four-row tapered roller bearings have seals positioned at both end surfaces and the middle bore notch. Basically, this type of bearing is similar to the four-row tapered roller bearing and has the following features:

- › Substantial reduction in the consumption of lubricating grease
- › Longer interval until disassembly and cleaning, thereby cutting-down on the maintenance costs
- › Cleaner environment around the rolling mill and roll shop
- › Prevention of sudden failure due to foreign particle entry
- › Longer bearing life is achieved by preventing water intrusion
- › Load capacity remains just as high as that of four-row tapered roller bearings without seals

Basically, there are two-seal and four-seal types of bearings. The standard feature of the sealed-clean tapered roller bearing is its ability to operate for a long time without the need for regreasing. Due to this feature, there are no oil holes in the cup spacers to supply lubrication to the bearing, but in the case of severe operating conditions, it could be designed to enable lubrication by making a lubrication groove and oil holes in the cup spacers. There is also a type compatible with oil-air lubrication.

Name and marking of parts

In addition to the bearing numbers, as shown in Fig. 1.2, the bearing is provided with a serial number that is common to one set of bearings and matching symbols indicating the combination order. The serial number is used to prevent mismatching during combination of bearings while matching symbols show the proper position of each part within a bearing. A wrong combination of these parts may cause an excessively small bearing clearance, resulting in seizure. On the other hand, an excessively large clearance due to a wrong combination may cause a reduction of the load zone, resulting in shorter fatigue life. The cup of a bearing is provided with load position numbers at four equally-divided points around the circumference. (These numbers are provided on the cone when the cup rotates.) So that the bearing life can be extended, each time the bearing is reassembled after disassembly and cleaning, be sure to shift the load position numbers by 90° to change the load zone.

Fig. 1.2 Name of parts and marking examples (Sealed-clean tapered roller bearing)

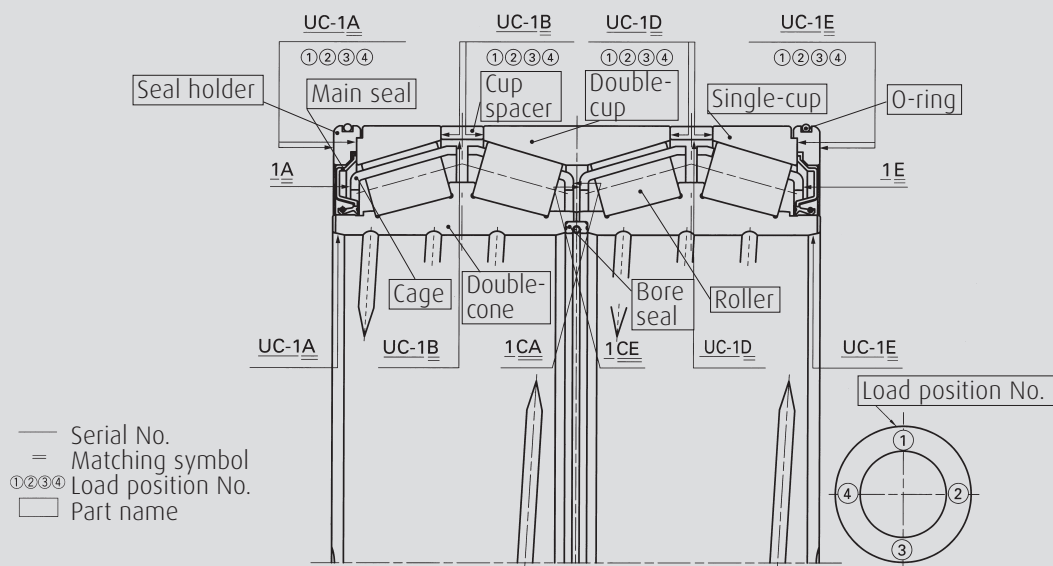

Note: Some markings may be omitted if the marking space is not enough.

1. Features, Part Name, and Marking by Bearing Type

1.3 Four-row cylindrical roller bearing, RV and RVK

A four-row cylindrical roller bearing is used in the work roll neck of wire, steel shape, and blooming mills, as well as in the backup roll of refining, hot, and cold rolling mills. This type of bearing has an outer ring rib that is either integrated with or separated from the outer ring. The inner ring is also either an integrated or a two-piece combination type. The bearing having a tapered bore type inner ring has "K" added to the bearing number. Both types of four-row cylindrical roller bearings carry radial load only and cannot carry axial load. A four-row cylindrical roller bearing is used in combination with another bearing type, such as an angular contact ball bearing set, or a tapered roller thrust bearing, or the like. Since the raceway surface of the inner ring is cylindrical, it is easy to disassemble the outer ring assembly and inner ring. The roll can be reground with reference to the raceway surface of the inner ring that is tightly fitted to the roll neck. When a grinding allowance is provided for the inner ring raceway surface and ground together with the roll barrel after fitting to the roll neck, the roll run-out can be minimized. Accordingly, a four-row cylindrical roller bearing is best suited and used frequently as a backup roll bearing to assure precise product thickness.

Name and marking of parts

In addition to the bearing number, as shown in Fig. 1.3, the bearing is provided with a serial number that is common to one set of bearings and matching symbols indicating the proper combination order. The serial number is used to prevent mismatching during combination of bearings while matching symbols show the proper position of each part within a bearing. A wrong combination of these parts may cause an excessively small bearing clearance, resulting in seizure. On the other hand, an excessively large clearance due to a wrong combination may cause reduction of the load zone, resulting in a shorter fatigue life. The outer ring of a bearing is provided with load position numbers at four equally divided points around the circumference. (These numbers are provided on the inner ring when the outer ring rotates.) So that the bearing life can be extended, each time the bearing is reassembled after disassembly and cleaning, shift the load position numbers by 90° to change the load zone.

Fig. 1.3 Name of parts and marking examples (Four-row cylindrical roller bearing)

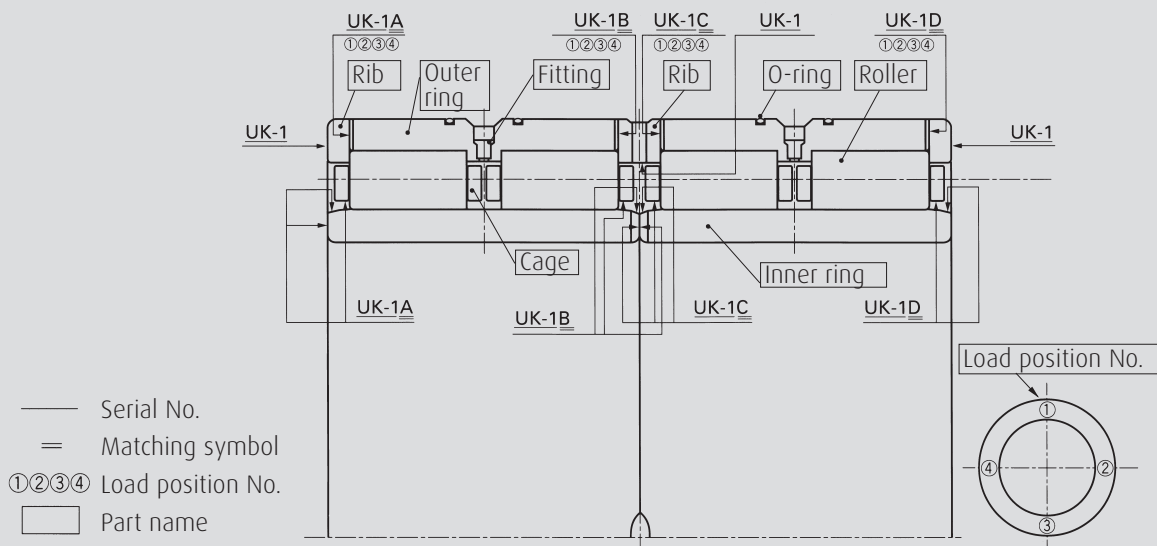

1.4 Double-cone tapered roller bearing, KDH, KH (TDI)

This type of bearing consists of a double-cone with rollers and two single-cups with or without a cup spacer. KDH Type has a steeper contact angle than the KH Type. This bearing is designed specifically for axial load and generally has a sufficient clearance between the housing bore and cup to avoid any radial load. The type without a cup spacer has a spring between the housing shoulder and cup end face. This spring preloads the bearing during use. The inner ring bore surface is loose-fitted to the shaft, with a keyway provided in the cone to prevent creep.

Name and marking of parts

In addition to the bearing number, as shown in Fig. 1.4, the bearing is provided with a serial number that is common to one set of bearings and matching symbols indicating the proper combination order.

The serial number is used to prevent mismatching during combination of bearings while matching symbols show the proper position of each part within a bearing.

Fig. 1.4 Name of parts and marking examples (Double-row tapered roller bearing with steep angle)

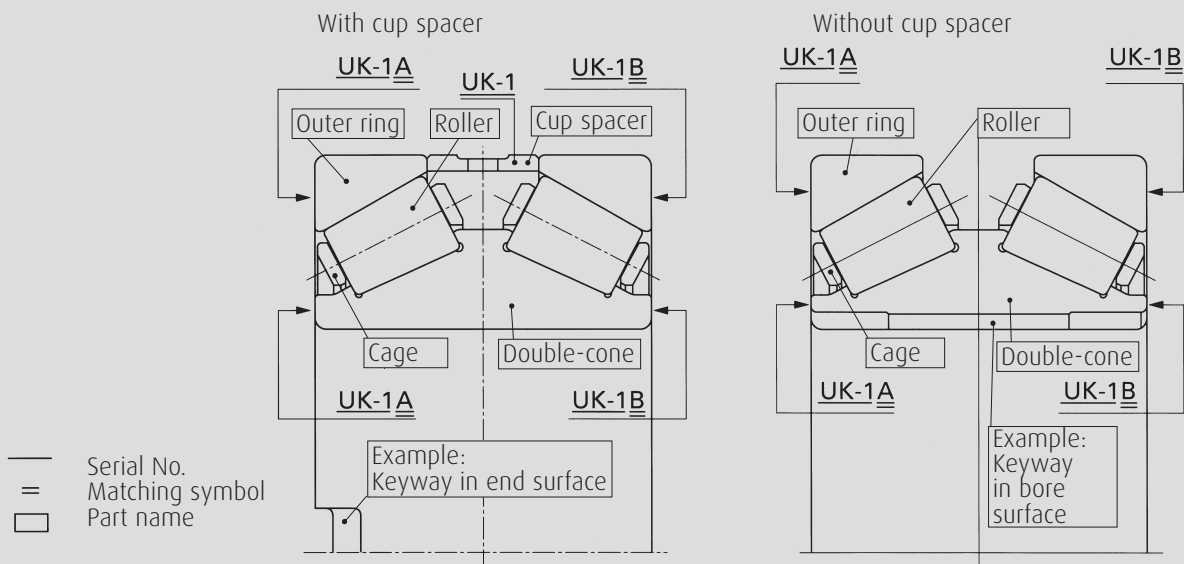

1. Features, Part Name, and Marking by Bearing Type

1.5 Double-direction tapered roller thrust bearing, TFD

This type of bearing can carry the net axial load in both directions and can support a heavier load than the double-row tapered roller bearing with steep angle. For higher loads and larger impacts, provide a spring between the housing shoulder and outer ring end face, which causes the bearing to be preloaded during use.

Name and marking of parts

In addition to the bearing number, as shown in Fig. 1.5, the bearing is provided with a serial number that is common to one set of bearings and matching symbols indicating the proper combination order. The serial number is used to prevent mismatching during combination of bearings while matching symbols show the proper position of each part within the bearing.

Fig. 1.5 Name of parts and marking examples (Double-direction tapered roller thrust bearing)

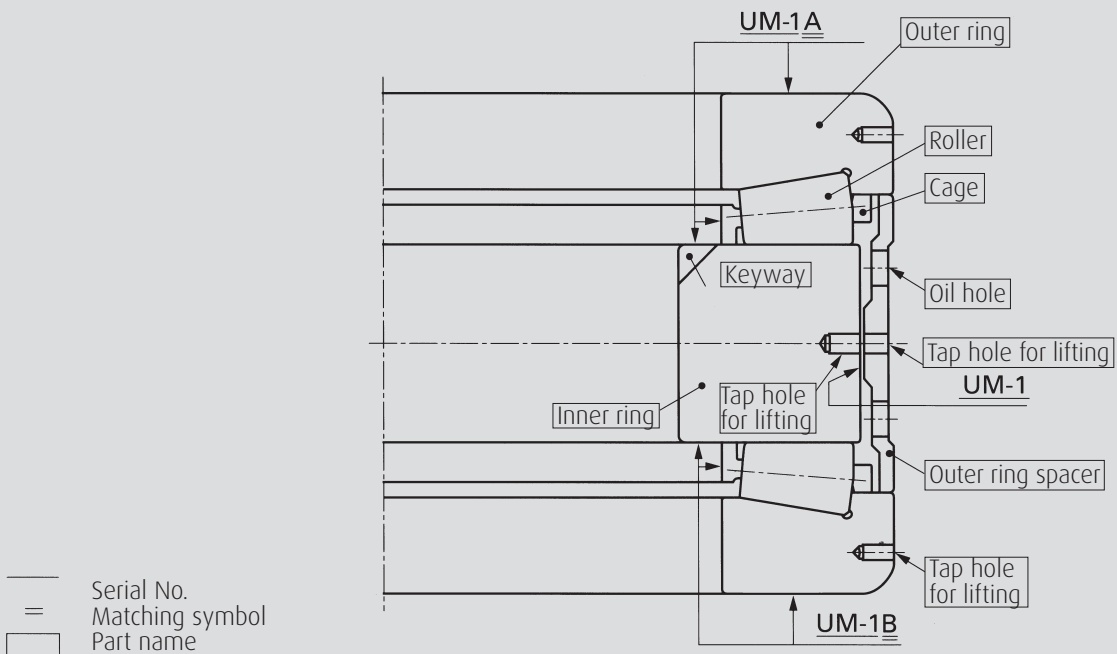

2. Cautions for Handling

2.1 Before assembling

1. Store the bearing in a clean, non-humid place which is not exposed to direct sunshine. The wooden box containing the bearing must not be placed directly on the floor. It needs to be elevated to allow air flow between the box and floor.
2. Do not unpack the bearing until immediately before installation.
3. Keep the environment clean by taking care not to allow any sand, iron powder, and dust to contaminate the bearing during assembly.
4. Clean the roll neck and chock bore surfaces to completely remove any dust.
5. Check carefully if the roll neck diameter and chock bore dimensions are within the allowable tolerance range and if the corner chamfering dimensions of the roll neck and chock bore are as specified, then begin to assemble. For a new chock, sufficiently flush the chock oil hole until all metallic powder and other foreign materials are removed.

2.2 Required Tools

1. Lifting tool: Used to assemble or remove bearing parts from the chock. Select a lifting tool appropriate in strength and function for each bearing type.
2. Tools: Spanners, wrenches, and screwdrivers, which are appropriate for the application.
3. Block: Used to secure a space for insertion of the lifting tool claw under the bearing.
4. Brass rod: Used to true a bearing when it has become cocked during assembly or removal.

Fig. 2.1 Bearing lifting tools

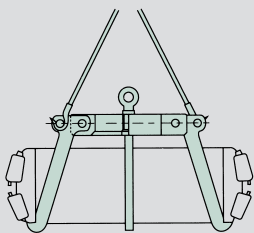

1. Lifting tool for double-cone (a)

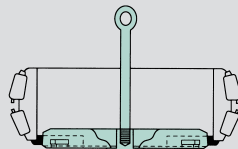

2. Lifting tool for double-cone (b)

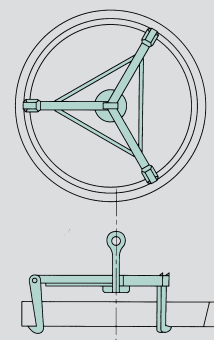

3. Lifting tool for single-cup (a)

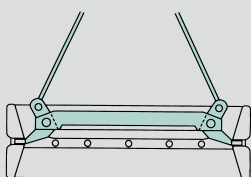

4. Lifting tool for double-cup (b)

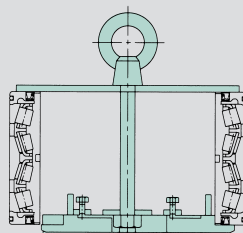

5. Lifting tool set (a)

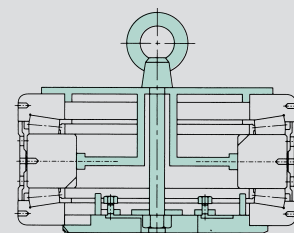

6. Lifting tool set (b)

3. Bearing Assembling Procedure

3.1 Four-row tapered roller bearing, KV (TQO)

3.1.1 Assembling procedure

Check the serial number and matching symbols on the bearing to be assembled. Confirm also, that related parts (chock, roll neck, etc.) are within the specified dimensions and tolerances. In this description, it is assumed that the bearing to be assembled has a matching symbol A on the barrel side and that the load position No. 1 is in the maximum load position. (The chock shown has a typical construction.)

1. Apply grease to the chock bore surface and over all the surfaces of the single-cup with matching symbols A-B.
2. Lift the single-cup (with matching symbols A-B) with a lifting tool, determine the proper load position number, and insert the cup into the chock with care, making sure the load position number is in the maximum load position. (Fig. 3.1) (If the single-cup becomes cocked, tap it lightly with a brass rod to correct its position.)
3. Insert the cup spacer with matching symbol B.
4. Apply grease to the bore surface and end surface of the cone with matching symbols A-CA.
5. Apply grease to both of the cage and roller sets. Turn the cage and roller sets to spread the grease to the cone raceway and rib surfaces.
6. Lift to assemble the cone, with the matching symbol A side facing downward, by the lifting tool. (Fig. 3.2)
7. Apply grease over all the surfaces of the double-cup.
8. Lift the double-cup, with the matching symbol B side facing downward, with a lifting tool, then match the load position numbers, and assemble it with care. (If the double-cup becomes cocked, tap it lightly with a brass rod to correct its position.)
9. Apply grease over all the surfaces of cone spacer, and assemble it with the rib side facing downward. (Fig. 3.3)
10. Insert the cup spacer with matching symbol D.
11. Apply grease to the bore and end surfaces of the cone with matching symbols CE-E.

12. Apply grease to both cage and roller sets. Turn the cage and roller sets to spread lubricant to the inside of the bearing (cone raceway and rib surfaces).
13. Lift the cone, with the matching symbol E side facing upward, and assemble it into the chock. (Fig. 3.4)
14. Apply grease over all the surfaces of the single-cup with matching symbols D-E, set the position of the load position number, and insert the cup with care. (Fig. 3.5) (If the single-cup becomes cocked, tap it lightly with a brass rod to correct its position. Take care not to knock the cage end surface.)
15. Installing (removing) the lid.
The assorted lid shapes are due to the diversity of rolling mills. Be sure to follow the maintenance manual of the mill builder when installing (removing) the lid.

3.1.2 After assembly

1. Pay due attention to centering during the assembly of the roll and chock, and be careful not to damage the chock seal.
2. With an oil stone, correct any scoring on the fillet ring end surfaces, end-retainer end surfaces, and roll neck surface.
3. During the assembly of the roll and chock, tighten the adjusting nut until snug, then back-off the nut for a given amount, and then lock the nut.
The nut back-off amount must be 1/8 - 1/6 of a turn for large bearings (nut pitch 5 mm or more) or 1/6 - 1/4 turn for small ones.

NOTE

4-row tapered roller bearings which are used with exclusive thrust bearings (KDH, KH, TFD) are designed to have a sufficient clearance (example: 10 - 15mm) between the inner ring end face and mating part.

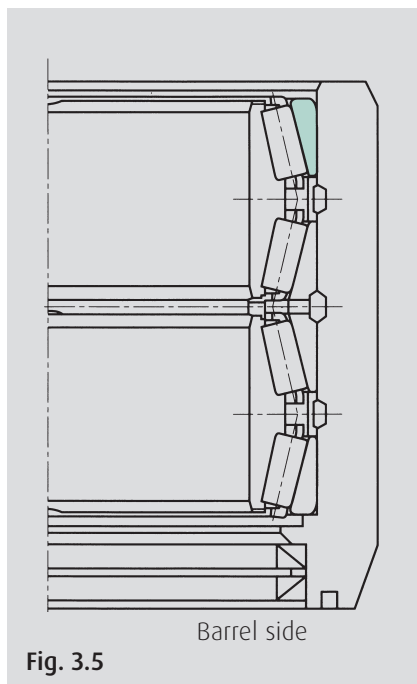
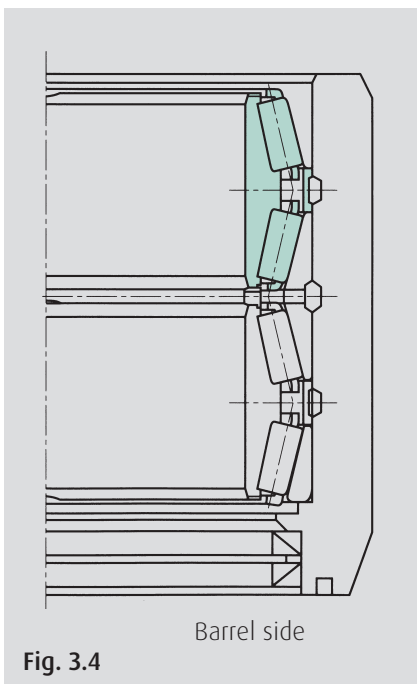
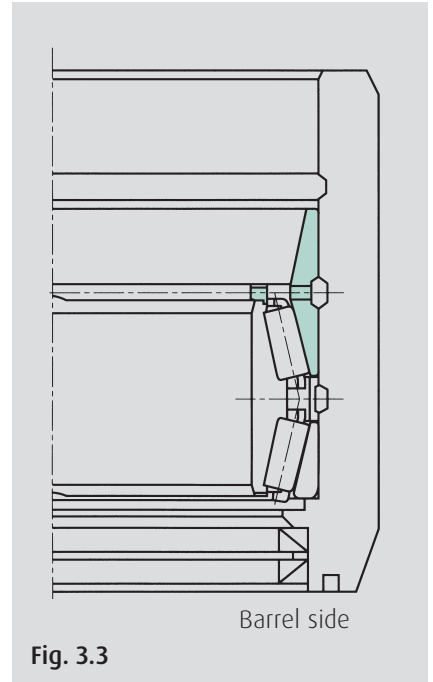
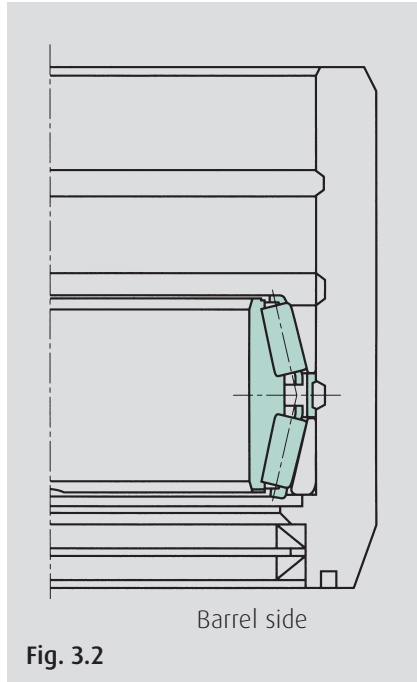
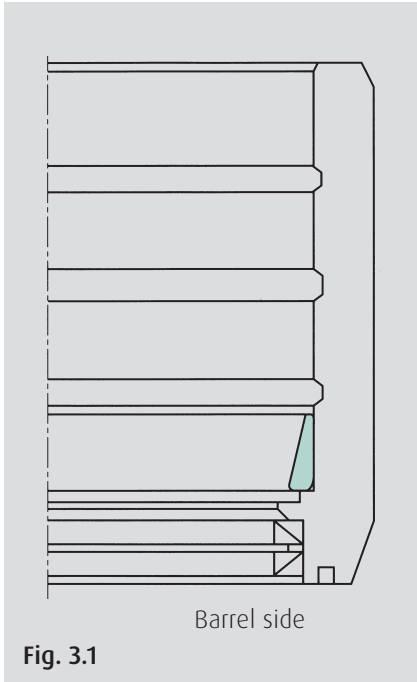

3. Bearing Assembling Procedure

3.1.3 Handling of tapered bore four-row tapered roller bearing, KWK (TQIT)

To tight-fit the roll neck and cone bore surfaces, install a bearing with a tapered cone bore to the tapered roll neck. Before assembly, be sure to match the tapers of the bearing bore and roll neck. To install the bearing, assemble it into the shaft housing (similarly to the case of a normal four-row tapered roller bearing). Then, assemble the chock, in which the bearing has been assembled, to the tapered roll neck as follows:

Installing the tapered bore bearing

1. Match the angle of tapered bore
To press fit the tapered bore bearing, a 1/12 taper is generally used, but a 1/30 taper may also be used. To measure the tapered section, apply a thin (less than 4 μm) coat of blueing over the bore surface of a taper gauge as shown in Fig. 3.6 and set the gauge to the roll neck surface to check the contact. The recommended contact is 70% or more of the total area. In the case of a large diameter, the gauge becomes very heavy, making the measurement too difficult. For this case, use a sine bar as shown in Fig. 3.7, measure the value of dimensions A and B using a micrometer, and judge whether it is acceptable or not according to the difference between measured values at A and B.
2. Cleaning of the tapered bearing journal before installation
An excessive amount of lube could result in an inadequate fit between the bearing and journal. This inadequate fit could result in an accident due to the bearing releasing itself from the tapered journal. It is therefore necessary to clean the fitting surface of neck and cone bore faces with a detergent.
3. Control of the tightening allowance
For a tight-fit bearing, control of the tightening allowance is most important. Adjust the fillet ring width with a taper gauge (ring gauge), so that the taper neck diameter becomes constant at the fillet ring end position. It is essential that the specified tightening allowance be made for the bearing when it is press fitted to contact the fillet ring.
4. Press-fitting and removal
Press fit the tapered bore bearing onto the tapered roll neck with a hydraulic ram as shown in Fig. 3.8. For removal, apply oil pressure to the oil hole which leads the oil to the bearing fitting surfaces. (Fig. 3.9)
5. Press-fitting force on the tapered bore cone
The force to fit a bearing onto the tapered roll neck is calculated as follows:
$$P = M \cdot \mu \cdot P_m$$
$$M = \pi \cdot d \cdot B$$
$$P_m = \frac{E}{2} \cdot \frac{\Delta d}{d} \left(1 - \frac{d^2}{D_i^2}\right)$$
where;
 P : Press fitting force (N){kgf}
 M : Contact area between the bearing bore and shaft (mm²)
 P_m : Surface pressure at the fitting surface (N/mm²){kgf/mm²}
 E : Young's modulus (208 kN/mm²) {21 200 kgf/mm²}
 μ : Coefficient of friction between bearing bore and shaft ($\mu = 0.165$)
 d : Mean bore of cone (mm)
 D_i : Effective raceway diameter of cone (mm)
 Δd : Interference between the bearing bore and shaft (mm)
 B : Bearing cone width (mm)

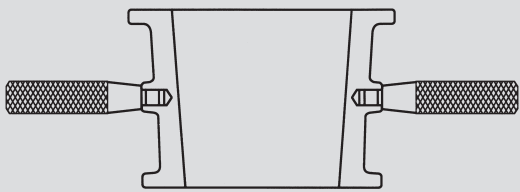

Fig. 3.6 Ring gauge to measure the roll neck taper

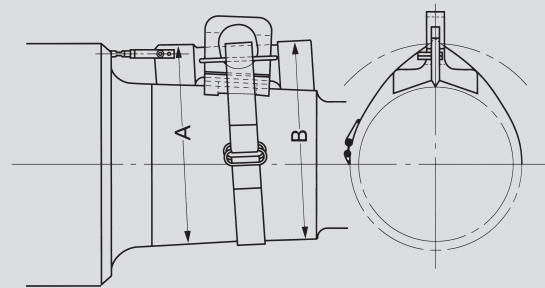

Fig. 3.7 Roll neck taper measurement with sine bar

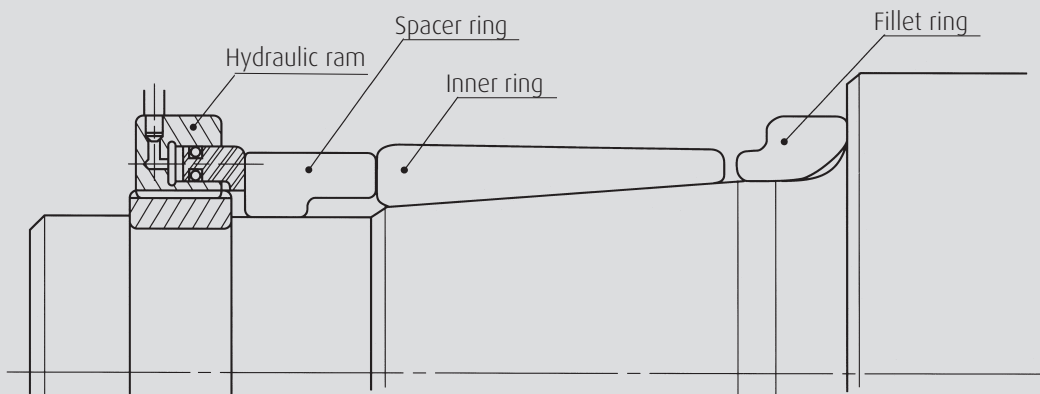

Fig. 3.8 Press-fitting hydraulic ram

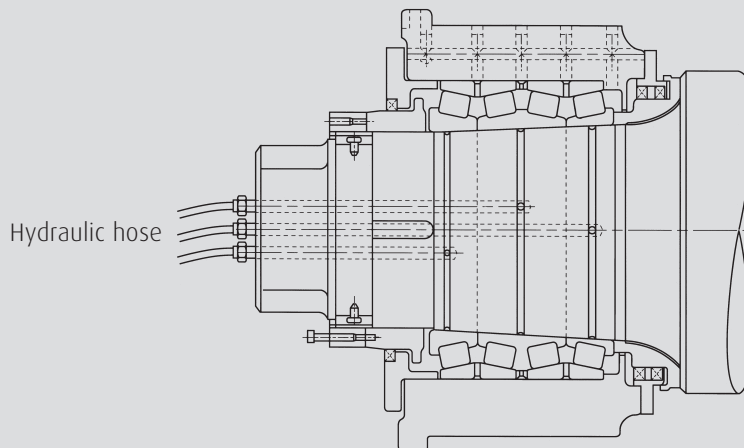

Fig. 3.9 Hydraulic removal of press-fit tapered bore bearing

3. Bearing Assembling Procedure

3.2 Sealed-Clean four-row tapered roller bearing, KVS

3.2.1 Assembling the bearing

In this description, it is assumed that the assembly begins with a part's matching symbol A being assembled first into the chock and that the load position number ① is at the maximum load position. Unless a specific designation such as "neck grease" is given, the grease refers to the grease inside the bearing.

1. Place blocks at appropriate intervals according to the bearing size.
2. Fit the main seal and O-ring to the seal holder with matching symbol A. Check to make sure that they are correctly fitted. When mounting the main seal to seal holder, take extra care to ensure the following items:
 - › Assemble the main seal to the seal holder on a flat surface, such as that of a sturdy workbench.
 - › Tap the side of the outside diameter of the main seal core evenly along the circumference with a plastic hammer and gradually insert the main seal core into the seal holder.
 - › Do not tap the seal lip with the plastic hammer, otherwise serious damage may occur.
3. Apply a thin coat of grease over all the surfaces of the seal holder, and a thick coat of grease over the seal lip and O-ring. Verify the load position number and then place the bearing as shown in Fig. 3.10.
4. Apply a thin coat of grease over all the surfaces of the single-cup with matching symbols A-B.
5. Assemble the bearing to the seal holder while allowing load position numbers to match each other. (Fig. 3.11)
6. Apply a thin coat of grease over all the surfaces of the cup spacer with matching symbol B and assemble by matching it to the cup.
7. Apply grease to the end surface of the cone with matching symbol A.
8. Fill the cage and roller assembly with grease. The amount of filling grease must be measured correctly to the specified amount. During filling, rotate the cage and rollers to spread the grease into the bearing (cone raceway and rib surfaces) evenly.
9. Assemble the cone with the matching symbol A side facing downward. Assembly should be done while rotating the cone. (Fig. 3.12) During the assembly, carry out the centering process with care, so that the cone end surface does not damage the main seal. After assembly, confirm that the main seal is correctly assembled to the raceway surface.
10. Apply a thin coat of grease over the entire surface of the double-cup.
11. With the matching symbol B side facing downward, make sure the load position numbers match each other for assembly. Assemble the double-cup firmly enough until the cup contacts the spacer tightly. (Fig. 3.13) Apply a thin coat of grease over all the surfaces of the cup spacer with matching symbol D and assemble while matching it to the cup.
12. Apply grease to the end surfaces of the cone with matching symbols CE-E and to the seal lip journal.
13. Fill the cage and roller assembly with grease, in the same manner as described in step (8).
14. Assemble the cone with the matching symbol E side facing upward while rotating the cone. (Fig. 3.14)
15. Apply a thin coat of grease over all the surfaces of the single-cup with matching symbols D-E.
16. Make sure the load position numbers match each other and assemble firmly enough until the cup contacts the spacer tightly. (Fig. 3.15)
17. Fit the main seal and O-ring to the seal holder with matching symbol E. Check to make sure that they are correctly fitted.
18. Apply a thin coat of grease over all the surfaces of the seal holder. After applying a sufficient amount of grease over the main seal lip and O-ring, assemble the seal holder. Verify that the load position numbers match each other.
19. After assembly, confirm that the main seal lip is correctly mounted on the journal of the cone.
20. Install a bore seal in the notch of the cone bore. (Fig. 3.16)

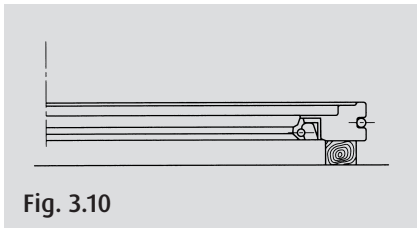

Fig. 3.10

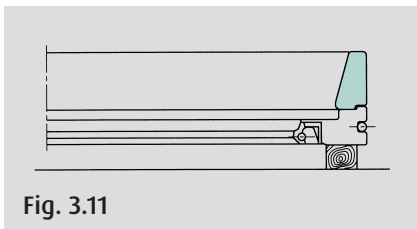

Fig. 3.11

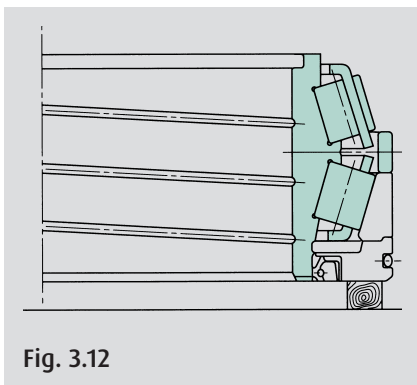

Fig. 3.12

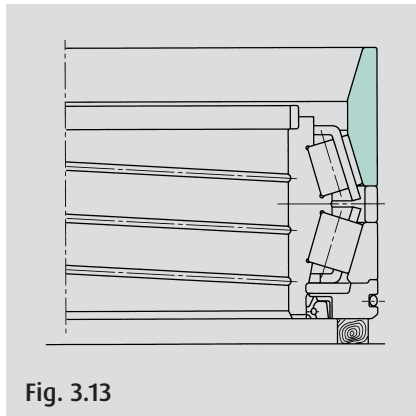

Fig. 3.13

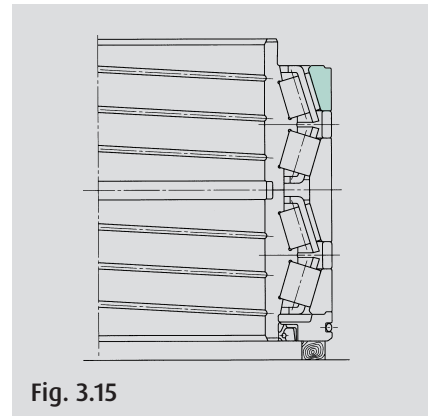

Fig. 3.15

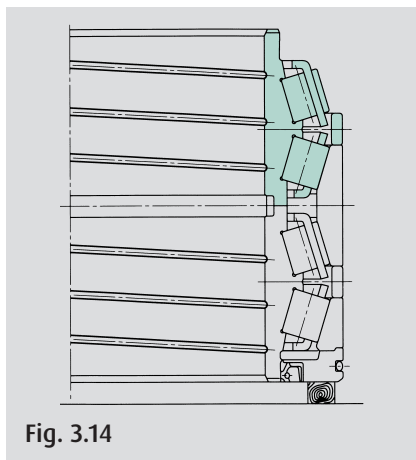

Fig. 3.14

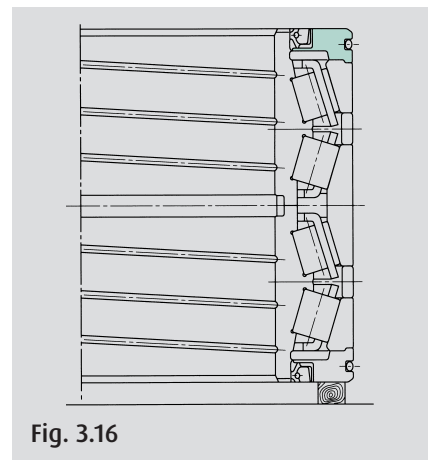

Fig. 3.16

3.2.2 After the bearing is assembled

1. Check the assembled bearing from the side. A line is indicated on the outside of the cups and seal holders at load position No. 1. Confirm that the markings on the single-cups are properly aligned with the markings on the double-cup as illustrated in Fig. 3.17. If the cup spacer outside is not matched to the cup, tap it lightly with a plastic hammer to eliminate any projection of the cup spacer from the cup outside.
2. Confirm that the main seal, bore seal, and O-ring are mounted correctly.
3. Apply a thin coat of grease over the bearing outside and end surface, if this has not already been applied.
4. Apply sufficient neck grease that is dedicated for roll necks to the bearing bore surface.

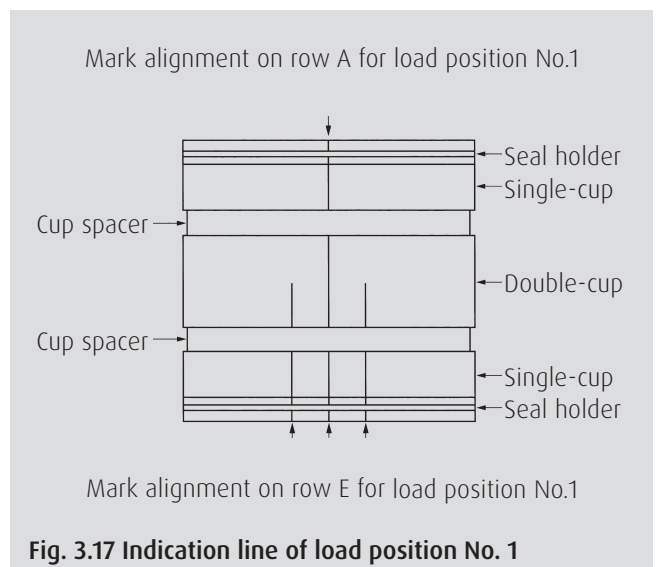

Fig. 3.17 Indication line of load position No. 1

3. Bearing Assembling Procedure

3.2.3 Lifting tool precautions

When using a lifting jig, take care to hook the lifting jig claw on the seal holder and not the seal itself. If the end surface of the cone is hooked, damage to the main seal will occur. (Fig. 3.18)

3.2.4 Cautions for the assembly of the bearing in the chock

1. Place the chock on a flat surface so that the chock bore center line is vertical. Clean the bore and apply a thin coat of grease.
2. Mark the maximum load position on the chock end face.
3. Use the appropriate lifting tool as shown in Fig. 3.20 when taking the bearing out of the wooden box, or handling the inner ring properly, as well as when assembling the bearing to the chock.
4. Before assembly, confirm that the oil seal and O-ring are free from abnormality.
5. During assembly, tap the bearing lightly with a brass rod to correct its position if it has become cocked. Note in this case that the bearing end surface must not be hit directly. Apply a patch plate or tap the top of the lifting tool lid.
6. Change the load position number of the bearing each time the bearing is reassembled after disassembly and cleaning. The load position changes will contribute to a longer life.

3.2.5 Assembly of the bearing in the chock

1. After filling with grease and assembling the bearing, lift it with a lifting tool in compliance with the procedure described in 3.2.6.
2. Set the load position mark of the bearing to the maximum load position of the chock and insert the bearing into the chock slowly while paying attention to ensure centering and avoid inclination.
3. Assemble the bearing until the bearing end surface contacts the chock shoulder tightly.
4. After assembly of the bearing into the chock, install the holder lid. The holder lid is available in various shapes due to the diversity of recent rolling mills. Install (remove) the holder lid in compliance with the maintenance manual of the mill builder.

3.2.6 Handling the lifting tool (example)

1. Pull levers to retract the claws into the main body, then insert the lifting tool into the bearing bore.
2. Push levers to extend the claws. After confirmation that the claw upper end surface tightly contacts the bearing end surface, tighten the fixing bolt.
3. Set the top lid at a right angle to the main body and tighten the eye nut sufficiently.
4. Thread the wire through the eye bolt and lift the bearing slowly with a crane.
5. To assemble the bearing into a chock, allow the bearing center line to coincide with the chock bore center line as much as possible. Insert the bearing into the chock slowly while taking care to minimize changes in the wire's tension during insertion of the bearing into the chock.
6. After setting the bearing to the specified position, loosen the eye nut and retract the claws into the lifting tool body, then remove the lifting tool. For easy and firm assembling of the sealed-clean bearing, the use of a dedicated lifting tool is essential. For this purpose, provide a lifting tool insertion space as shown in Fig. 3.20. Consult NSK because the dimensions may vary depending on the chock weight and construction.

3.2.7 Cautions for the assembly of the roll and chock assembly with the bearing

1. Scoring on the fillet ring, thrust rib end surface, and roll neck, if any, must be corrected with an oil stone to become a smooth surface.
2. Apply a thin coat of neck grease that is dedicated for roll necks to the roll neck surface.
3. During assembly of the roll and chock, carry out centering while taking care not to damage the chock seal.
4. During assembly of the roll and chock, tighten the adjusting nut fully and back it off by a certain amount, then lock the nut. The back-off amount is 1/8 to 1/6 of a turn for large bearings (nut thread pitch to be 5 mm or more), and 1/6 to 1/4 for small bearings.
5. After completion of the assembly of the roll and chock, confirm that the drain hole in the chock is not blocked with grease.

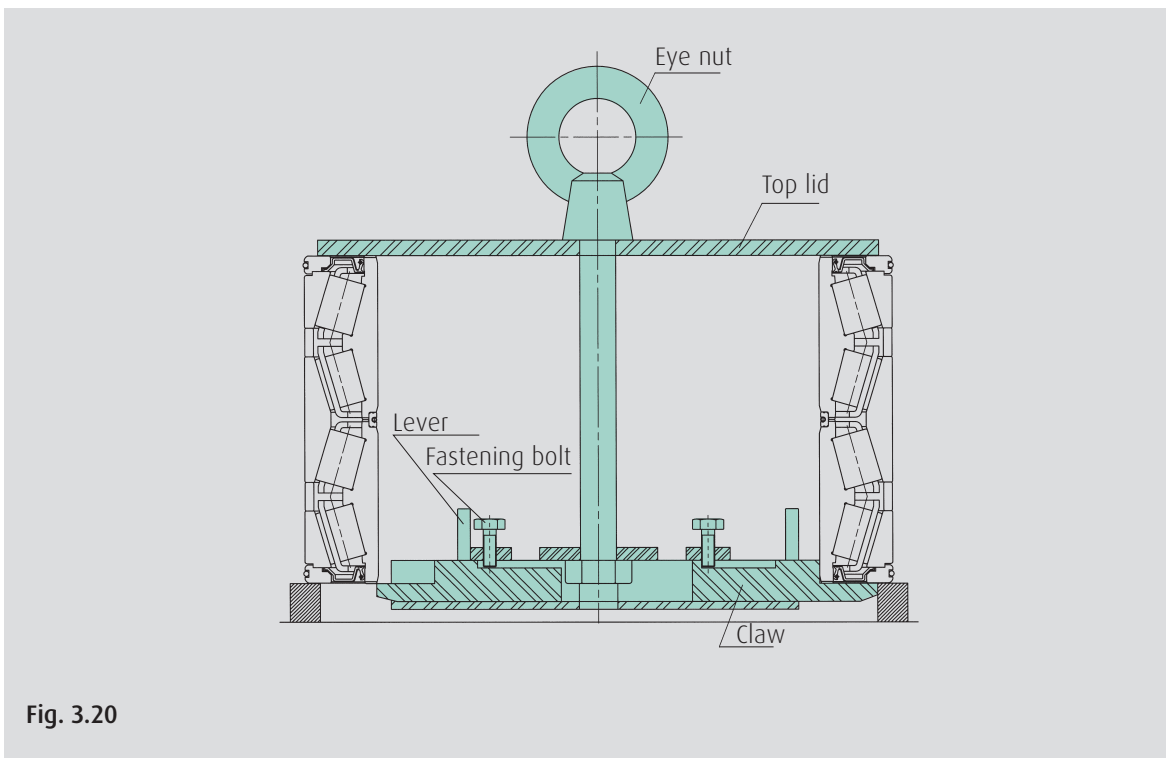
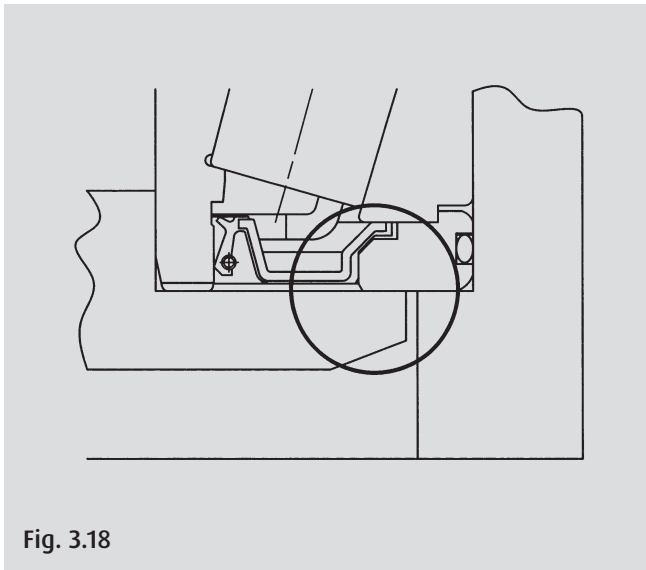

3. Bearing Assembling Procedure

3.3 Four-row cylindrical roller bearing, RV

3.3.1 Assembling the bearing into the chock

In this description, it is assumed that assembling begins with a part's matching symbol A on the barrel side and that the load position No. 1 is at the maximum load position. (The chock shown here has a typical construction and is an oil lubrication type bearing.)

1. Set the chock with the barrel side facing downward.
2. Apply the lubricant over the chock bore surface, and then apply the lubricant over all the surfaces of the rib ring.
3. Lift the rib ring with the marked end facing downward, and insert. (Fig. 3.21)
4. Use a clearance gauge to check if the rib ring end surface contacts the chock shoulder tightly.
5. Apply the lubricant over the outer ring with matching symbols A and B and over the roller's rolling surface, and both end surfaces of the row A rollers.
6. Place the outer ring with matching symbol A side facing downward on the cage with marked side (row A) facing downward. Install special eyebolts into the four tapped holes provided in the cage. Lift the cage and the outer ring, verify that the load position numbers match each other, and insert the outer ring into the chock. (Fig. 3.22) (If the outer ring becomes cocked, tap it lightly with a brass rod to correct its position.)
7. Apply the lubricant over the roller's rolling surface and to both end surfaces of the row B rollers.
8. Place the row B cage with the marked side (row B) facing upward, and install special eyebolts in the four tapped holes in the cage. Lift and insert the cage into the outer ring in the chock. (Fig. 3.23)
9. Apply the lubricant over all the surfaces of the rib ring and then insert it. In this case, the rib ring may be inserted by placing it on the roller end surface when the row B cage is to be assembled. Use the oil holes for lifting of the rib ring. (Fig. 3.24)
10. Apply the lubricant to the outer ring end surface with matching symbols C and D, and to the roller's rolling surface and both ends of the row C rollers.
11. Place the row C cage with the marked side (row C) facing downward, then place the outer ring with matching symbol C facing downward on the row C cage. Install special eyebolts into the four tapped holes in the cage. Lift the cage and the outer ring, verify that the load position numbers match each other, and insert it slowly into the chock. (Fig. 3.25) (If the outer ring becomes cocked, tap it lightly with a brass rod to correct its position.)
12. Apply the lubricant to the roller's rolling surface, and both ends of the row D rollers.
13. Apply the lubricant over all the surfaces of the rib ring.
14. Place the rib ring with matching symbol side facing upward on the row D cage. With the marked side facing upward, install special eyebolts into the four tapped holes in the cage, lift the cage assembly, and insert it slowly into the outer ring in the chock. (Fig. 3.26)
15. Holder lids are available in various shapes due to the diversity of recent rolling mills. Install (remove) the holder lid in compliance with the maintenance manual of the mill builder.

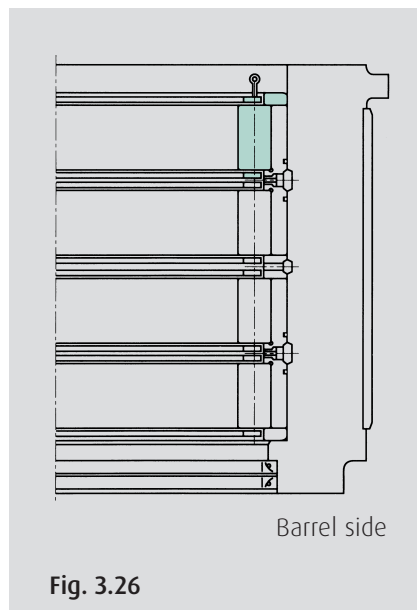
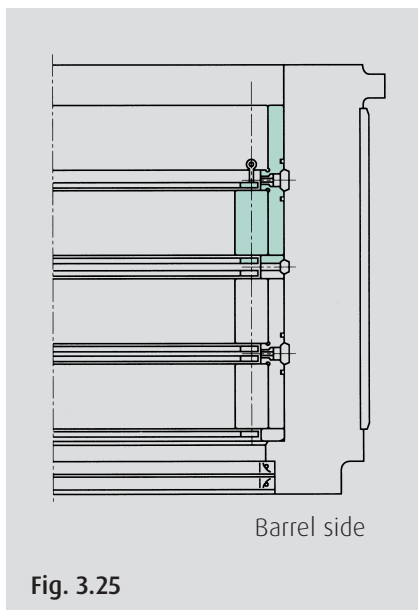
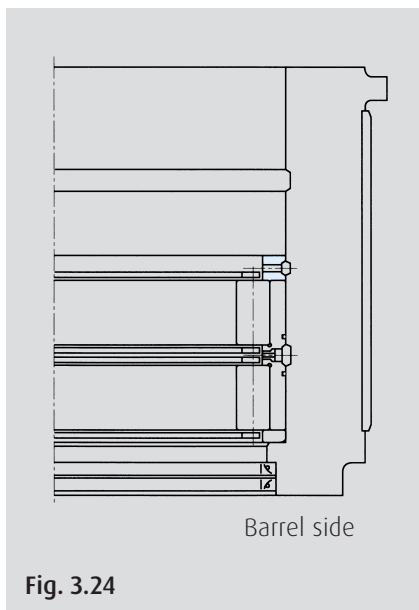
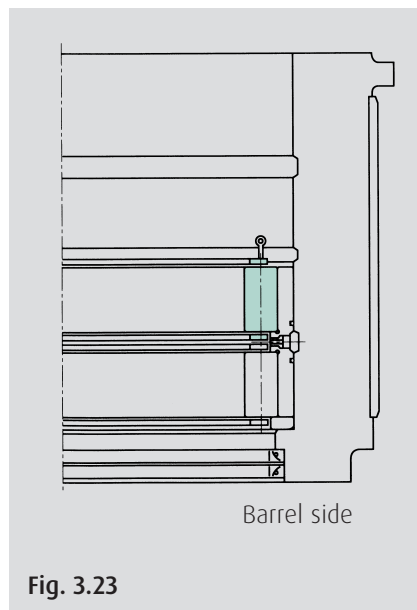
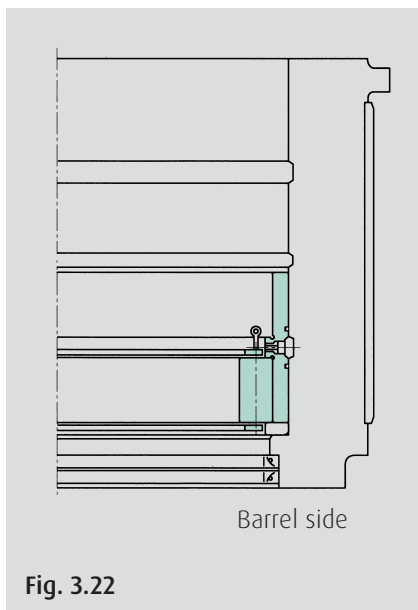
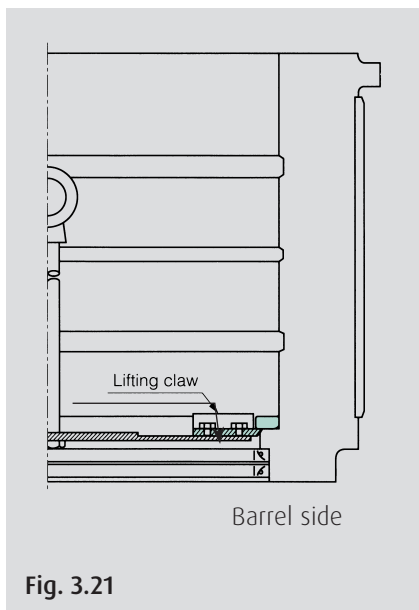

3. Bearing Assembling Procedure

3.3.2 How to install and remove the inner ring

When installing the bearing inner ring onto the roll, be sure to record the number of the rolls which the inner rings will be installed on, the inner ring serial number with reference to the installation position (work or drive side), and finally, confirm the dimensions (an inspection record attached to the inner ring). This will help in the maintenance of the bearing. Normally, the inner ring may be tightly fitted onto the roll neck by shrink fitting. The method is described below:

1. Heating in oil

To expand the inner ring, heat it in an oil bath at 100°C. Take care not to allow the temperature to exceed a maximum of 120°C.

- a. Lift the inner ring with a crane and install it onto the roll neck. Assemble the inner ring with matching symbol A and then with matching symbol B. The inner ring with the outside diameter of 180 mm or more is provided with an eccentricity mark E or O in the maximum eccentricity position on the side. Provide a mark for the minimum eccentricity position of the roll neck beforehand, to allow these marks to be matched during assembly.
- b. When cooling, the inner ring shrinks axially. Press the inner ring against the fillet ring to prevent a gap between the fillet ring and inner ring, or between inner rings.
- c. The size of an oil bath used for heating should be enough to contain two to five bearings. The depth should also be enough to immerse these bearings completely. Be sure to put a wire net or similar material in the bath as shown in Fig. 3.27 to prevent the bearings from contacting the bottom directly. Also, laying a beam over the top of the bath and hanging the bearings with a hook from the beam allows for ease of handling.

2. Induction heating

This is to heat the inner ring to the required temperature within a short period of time by an induction current, in order to expand it when an inner ring having a tight fit to the roll neck is to be installed or removed. The NSK induction heater features automatic demagnetization after heating, thus enabling easy removal of inner ring from a

roll neck. With this unit, no additional work of the roll neck (such as oil hole and groove for oil injection) is necessary. For details, contact NSK.

3.3.3 Installation onto the roll neck

Before installation of the inner ring onto the roll neck, confirm the serial number, matching symbol, and inner ring notch position. Fig. 3.29 shows an example of installation with matching symbol A on the fillet ring side. Installation of a heated inner ring to the roll neck will be easier if the inner ring is first fitted into a guide sleeve as shown in Fig. 3.29 (since the sleeve outside diameter is 1 - 1.5 mm smaller than the roll neck diameter). Before installing, be sure to clean the inner ring and roll neck. When the shrink fitting process is over, allow the bearing to cool completely and measure and record the diameter of the inner ring raceway.

3.3.4 Co-grinding of the roll barrel and inner ring raceway

When accuracy is demanded for rolled plates in aluminum foil and cold rolling mills, simultaneous finish grinding of the roll barrel and inner ring raceway track must be made after shrink fitting of the bearing inner ring to the roll neck. This is to minimize the runout between the inner ring raceway track and roll barrel. This method enhances the plate accuracy and is called "co-grinding."

1. Carry out grinding of the step (roll grinding support), which is a reference surface for the roll. After grinding, check the roundness, run-out, and cylindricity. (Fig. 3.30)
2. After grinding of the step (roll grinding support), grind the roll neck. After grinding, check the roundness, run-out, and cylindricity. (Fig. 3.31) Install the inner ring with its max. position (E or O) matched to the minimum run-out position of the roll neck.
3. Grind the raceway of the inner ring installed on the roll neck. (In this case, NSK will instruct the finish dimension and raceway surface roughness.) (Fig. 3.32)
4. When the work on the raceway surface of the inner ring is over, grind the roll barrel surface. (Fig. 3.33)

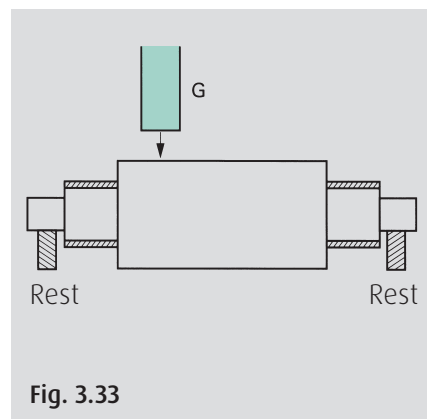
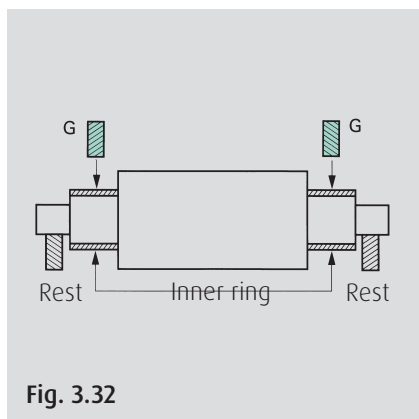
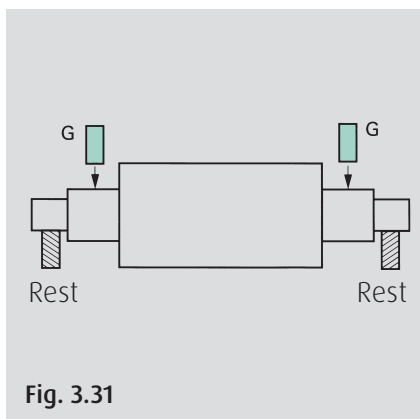
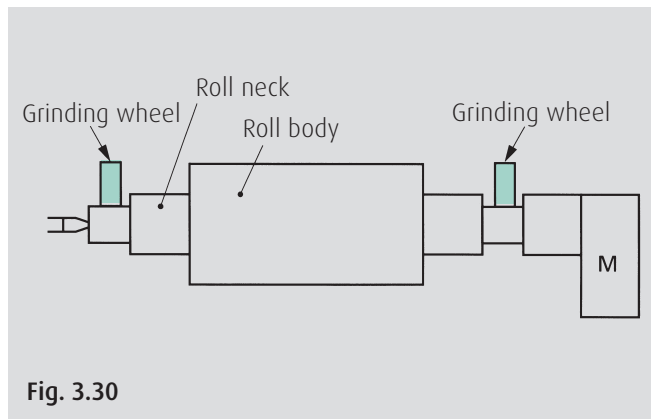
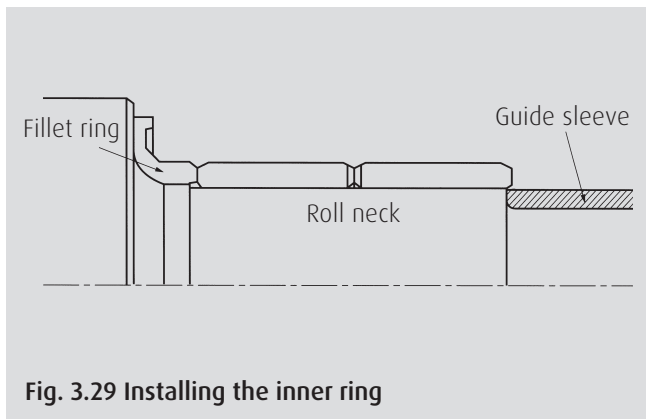
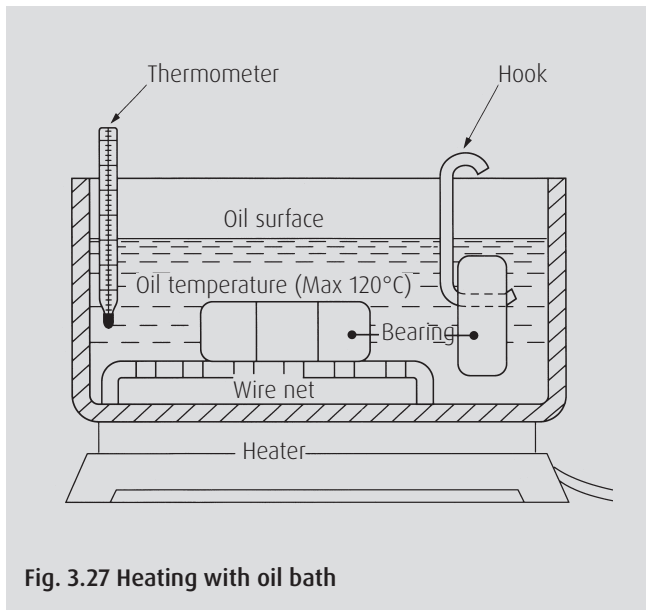

3. Bearing Assembling Procedure

3.4 Double-cone tapered roller bearing, KDH, KH (TDI)

3.4.1 Assembling the bearing into the chock

In this description, the part with matching symbol A is on the roll barrel side of the thrust block. (The thrust block shown has a typical construction.)

1. Set the thrust block with the barrel side down.
2. Apply the lubricant to the thrust block bore surface.
3. Apply the lubricant over all the cup surfaces with matching symbol A.
4. Lift the cup with a lifting tool and insert it slowly into the thrust block. (Fig. 3.34)
5. When the cup has a spacer, apply the lubricant to the cup spacer and insert it slowly into the block.
6. Apply the lubricant to the cone bore surface and both end surfaces, the roller's rolling surface, and both end surfaces, and the cup with matching symbol B. Rotate the cage and rollers to spread the lubricant to the cone raceway and rib surfaces.
7. Place the cup with matching symbol B on the cone assembly with matching symbol A down, install eyebolts into the four tapped holes in the cage. Lift them and insert slowly into the thrust block. (Fig. 3.35) For a window type press cage, use a lifting tool as shown in Fig. 2.1.
8. For a bearing without cup spacer and for which preloading is made with a spring, adjust the clearance according to the procedure described in Section 3.4.2.
9. Installing (removing) the holder lid. The holder lid is available in various shapes due to the diversity of recent rolling mills. Install (remove) the holder lid in compliance with the maintenance manual of the mill builder.

3.4.2 Clearance adjustment of the bearing using preload springs

Generally, the double-cone tapered roller bearing has no cup spacer and the bearing is preloaded with a spring. Adjust the clearance as described below.

1. Follow the steps from (1) to (7) of the procedure described in Section 3.4.1, but do not use the preload springs.
2. Tighten the end cover bolts temporarily.
3. Measure the clearance between the chock and end cover at four equally-divided points around the bolts and determine the average clearance (t). (Fig. 3.36).
4. Remove the end cover and install the springs, then assemble the bearing and install the shim of predetermined thickness (T). This thickness can be determined. (Fig. 3.37, Table 3.1)
5. Other cautions.
Depending on the type, the springs installed in the end cover are allowed to either drop or not. If the spring is a drop type, fill an adequate amount of grease in the spring hole to hold it by the viscosity of the grease.

Table 3.1

Spring allowance (Δa)	Predetermined shim thickness (T)
0.4 ~ 0.6	$T = \Delta a + t$

If the shim is not metallic, determine its thickness while taking the shim deflection allowance into account.

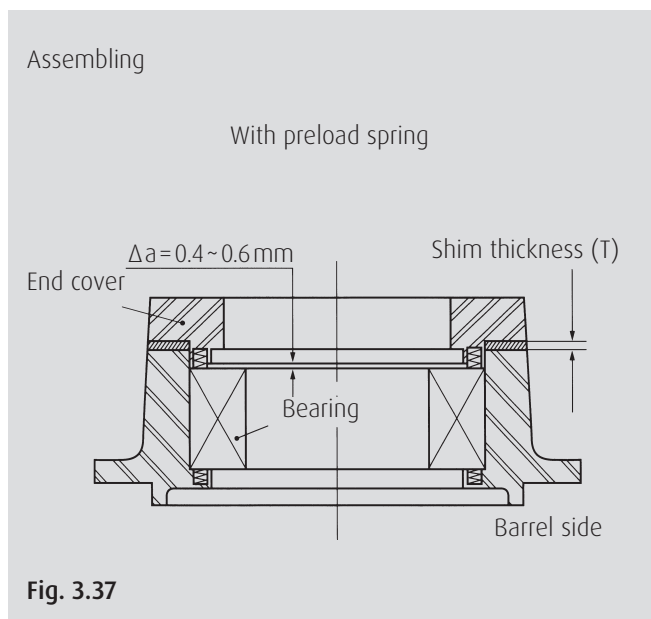
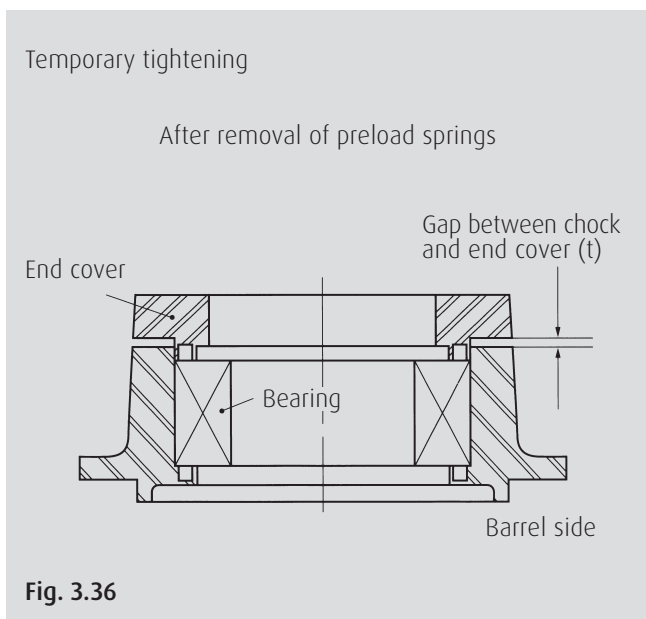
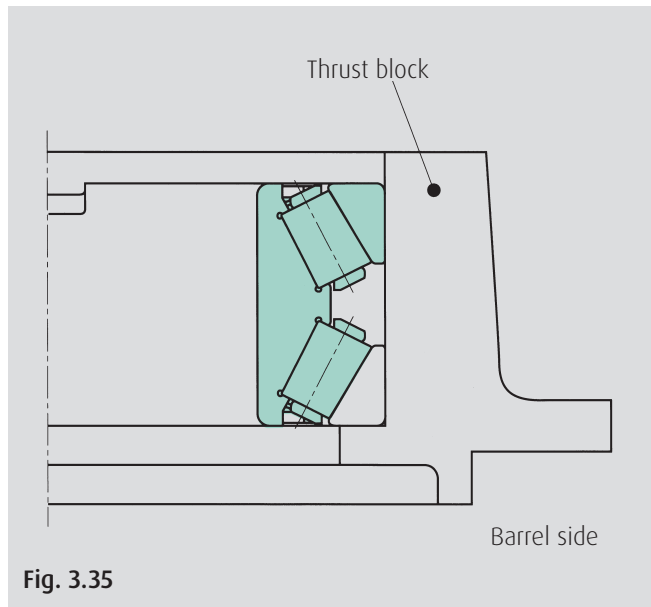
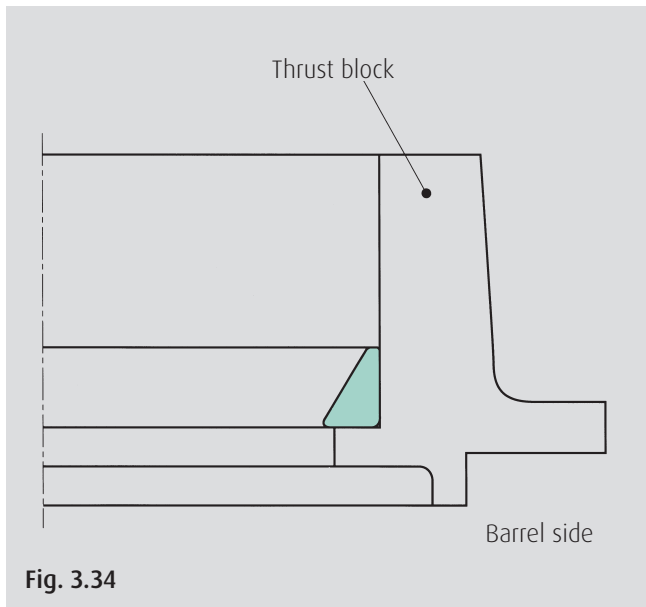

3. Bearing Assembling Procedure

3.5 Double-direction tapered roller thrust bearing, TFD

3.5.1 Assembling the bearing

1. Apply a thin coat of grease over the outer ring with matching symbol A and place the outer ring on the blocks with the raceway surface facing upward. (Fig. 3.38) Then, apply the specified amount of grease on the raceway surface as lubrication, spreading it evenly over the surface. Apply a sufficient amount of grease to the rib surface.
2. After applying specified amount of grease over the periphery of the cage and rollers with matching symbol A, then place them slowly on the outer ring. Check the cage direction by confirming that the cage contacts the outer ring at (Point A) and check that there is a clearance between the cage and outer ring at (Point B) as shown in Fig. 3.39.
3. After applying a thin coat of grease over the entire inner ring surface and carrying out its centering with care, then place it slowly onto the rollers. After placement, apply the specified amount of grease over the entire raceway periphery. (Fig. 3.40)
4. Place the outer ring spacer, which has a thin grease coating, on the outer ring end surface (rib). (Fig. 3.41)
5. Place the cage and rollers with matching symbol B on the inner ring. Confirm that the cage evenly contacts the inner ring raceway at (Point C) of Fig. 3.42. Apply the specified amount of grease over the roller periphery. (Fig. 3.42)
6. Apply a thick coat of grease evenly over the entire periphery of the outer ring rib with matching symbol B. Apply a thin coat of grease over the other surfaces. Place the outer ring slowly onto the rollers. (Fig. 3.43) Carry out centering with care. Fill specified amount of grease through the oil hole of the outer ring spacer into the bearing. Apply the specified amount of grease in the oil hole and groove of the outer ring. Apply a thin coat of grease over the outside surface. Using a tool as shown in Fig. 2.1.6, assemble the bearing assembly into the chock.

3.5.2 Adjusting the bearing holder lid during assembly

1. Remove the preload spring from the chock.
2. Using a jig, assemble the bearing into the chock.
3. Remove the O-ring and preload spring from the bearing holder lid, and install the holder lid on the chock.
4. Tighten the holder lid bolts temporarily.
5. Measure the clearance between the chock end surface and lid flange surface (Δsp) with a clearance gauge at several points around the bolts and determine the average (Δsp). (Fig. 3.44)
6. Set the shim combination thickness (Δsm) as follows:
$$\Delta sm = \Delta sp + 0.5 \text{ (mm)}$$
7. Remove the lid and install the shim of set thickness (Δsm) on the lid.
8. Using a jig, remove the bearing from the chock, install the preload spring, and reassemble the bearing into the chock.
9. Mount the O-ring and spring to the lid and install the lid on the chock.
10. Tighten the lid bolts with an even torque.
11. After assembly, confirm that $CL1 + CL2 = 0.5\text{mm}$. (Fig. 3.45)

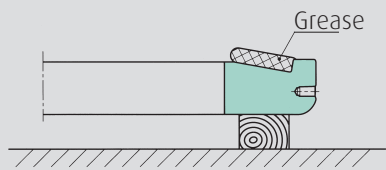

Fig. 3.38

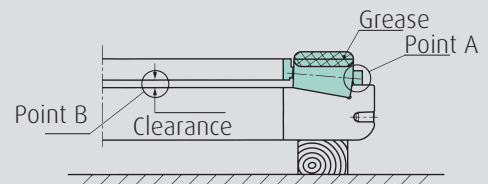

Fig. 3.39

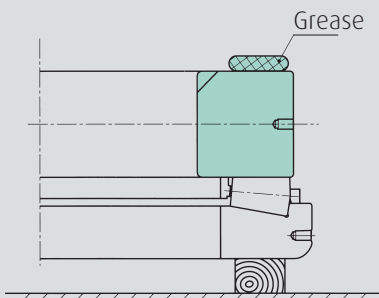

Fig. 3.40

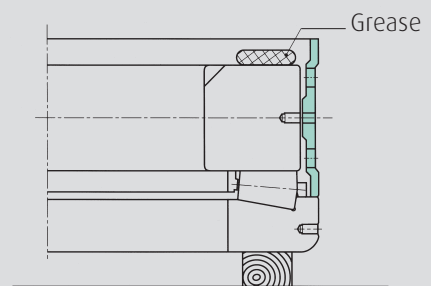

Fig. 3.41

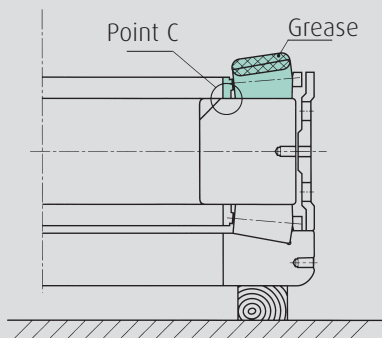

Fig. 3.42

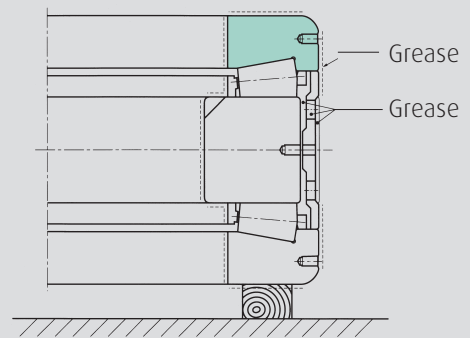

Fig. 3.43

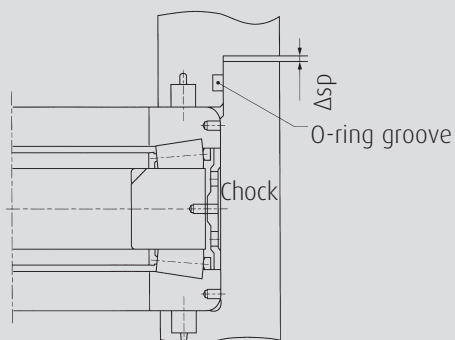

Fig. 3.44 Temporary assembly without preload springs

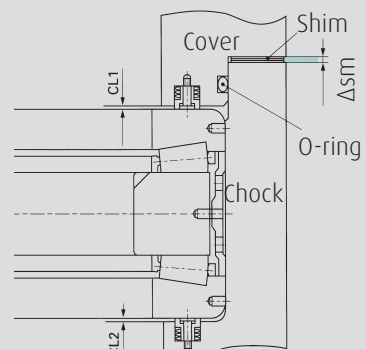

Fig. 3.45 Assembly with preload springs

4. Inspection Items

4.1 General inspection items

After the cleaning of a used roll neck bearing, carry out the inspection described below. Make any corrections necessary, so that the bearing will be ready for reuse.

1. Check if the bearing has been assembled in the order of the matching symbols.
2. Check the inner ring end surface for scoring or cracks. Remove scoring with oil stone, if any.
3. Check the inner ring bore surface for scoring, cracks, or discoloration.
4. Check the raceway surface of the outer or inner ring and the roller rolling surface for any abnormal contact. If there may be a moment load due to contact with the raceway surface, check the clearance between the chock liner and keeper plate for any abnormality and correct it if the clearance is larger than the standard. In the case of a four-row tapered roller bearing, strong contact of two rows may be attributed to insufficient tightening of the front lid. Readjust the packing thickness. For a relatively small bearing with strong contact of two outside rows, the problem may be due to overtightening of the front lid.
5. Check the raceways of the inner and outer rings and the roller rolling surface for flaking. Raceway and rolling surfaces may suffer fatigue due to repeated load after extended use, resulting in flaking. As a rule, bearings having such flaking must not be reused. If flaking is minor and occurs on the outer ring, grind the area around the flaking with a hand grinder as shown in Fig. 4.1, round off the boundary between raceway and ground surfaces with an oil stone, and change the load position for reuse. If the pin type cage has an inspection pin, remove the pin as shown in Fig. 4.2. The inner ring raceway can be checked.
6. Check the raceway and rollers for any rust. If rust is observed on the raceway and rollers, any minor rust can be removed with sand paper or oil stone. If there is deep-rooted rusting in an interval equivalent to roller pitch over the entire length of the roller, the bearing must be scrapped.
7. Check the rolling surface and rollers for any smearing. Minor smearing can be rounded off by an oil stone. By improving the lubrication at time of reuse, further progress of smearing can be prevented.
8. Check the raceway surfaces of the inner or outer ring and the roller rolling surface for excessive denting or assembly damage. Excessive dents due to inclusion of foreign materials may lead to early flaking. It is essential to remove the cause. Most important is to prevent foreign materials from mixing-in with the cooling water and entering the chock by improving the seal or by direct grease supply to the seal. It is also necessary to improve filtering of the circulating cooling water. Round off any assembly damage by oil stone or sand paper.
9. Check the roller for chipping or head scoring. Chipped roller end or excessive head scoring is a cause for scrapping. Minor scoring may allow further use of the bearing after improvement of lubrication.
10. Check the cage for abnormality. If a contact trace is observed at the cage surfaces (outside, bore, and end faces), which should originally not contact anywhere, substantial wear or scoring may occur in the cage pockets or pins (pin type cage) in contact with the rollers. It is generally required to improve the lubricating conditions.

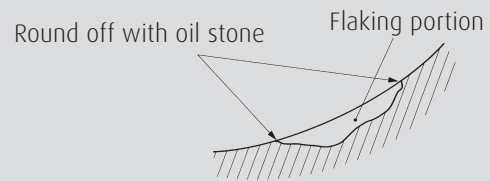
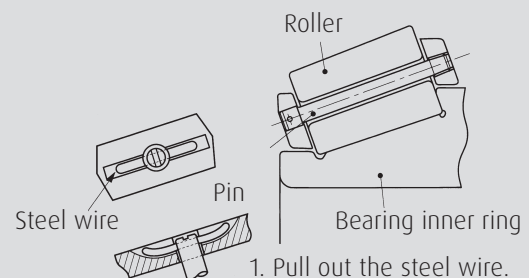

Fig. 4.1 Correction of flaking in the raceway surface



1. Pull out the steel wire.
2. Remove pin with a screwdriver.
3. Take out roller.

Fig. 4.2 How to remove the inspection pin for a pin type cage

4.2 Inspection of a sealed bearing

1. Separating the roll and chock
 - › Bearing disassembling
 - › Residual amount, state, foreign matter, and water drops in bearing grease
 - › Grease adhesion on the outer ring raceway and roller rolling surface
 - › Grease adhesion of the outer ring, rollers, cage and seal holder
2. Cleaning of bearing
 - › Wear, contact surface width, contact position of seal sliding surface
 - › Rust and dent in the seal holder end surface
 - › Pull-out, deformation, deformed garter spring, cuts in the main seal, cracks, and wear in the seal lip
 - › Replace main seal, bore seal, or O-ring if there is damage or wear. Especially if cracks in the seal lip can be observed when handling it, it should be replaced.

4.3 Inspection of parts other than bearing

When the chock is used for a long time, the chock bore is deformed due to difference in the thickness, rolling load, and fretting. Measure the chock bore once every year or two and keep a record of the roundness and wear amount. The roll neck diameter decreases also due to wear and regrinding and should be recorded. In this manner, the scrapping standard must be adjusted according to the practical conditions. The main seal is often damaged during mounting of the roll and chock, and should be replaced if any damage is found. In addition, the end surface of the thrust rib and fillet ring may develop fretting and step wear after long-time use. This causes excessively small contact area on the inner ring, resulting in scoring or thermal cracks in the inner ring end surface. Correct the end surface of the

thrust rib from time to time to eliminate such step wear. Control of the clearance between the chock liner and mill housing (window clearance) as well as that between the keeper plate and chock wing is also an important item. Increase in the clearance causes inclination of the chock, readily allowing a moment load on the bearing and resulting in premature flaking and seizure. Check the grease in the bearing periodically to know its mechanical and chemical properties as well as the degree of mixing-in of water and foreign materials. In particular, water, sand, and metallic powder shorten the life of the bearing. It is therefore necessary, depending on the degree of contamination, to review fundamentally the grease supply interval, supply method, and supply amount in addition to improvement of the seal.

4.4 Bearing service record

Keeping a record of the bearing's usage history and recording the results are quite important to ensure wise and long use of the bearings. Fig. 4.3 shows an example of a service record form. Each bearing requires its own form and each form registers the bearing serial number. The form also contains other data: the assembly date of such bearing, stand No., chock No., mounting position, rolling record and time, rolling tonnage, bearing inspection and correction history. This record should be referenced to schedule the purchasing of replacement bearings to ensure an adequate inventory. Besides, this is a valuable source of data for maintenance and improvement of the bearing.

For your reference, the recommended values for roll neck diameter and chock bore relative to the inner ring bore and outer ring outside diameter of the bearing to be used are shown in Tables 4.1~4.5.

4. Inspection Items

Fig. 4.3 Example of bearing service record

ROLL NECK BEARING SERVICE RECORD																
Name of rolling mill _____				Roll bearing _____				Lubricant _____								
Bearing No. _____				Date of acceptance _____				Total rolling time _____								
Boundary dimensions _____				Operation start date _____				Cumulative rolling tonnage _____								
Bearing serial No. _____				Scrapping date _____												
Bearing clearance _____				Reason for scrapping _____												
Reassembling frequency	Assembling		Chock No.	Roll No.	Stand No.	Mounting position	Outer ring load position No.	Removal		Rolling time	Rolling tonnage	Cumulative rolling tonnage	Date of inspection		Lubricant state	Remarks
	Date	Time						Date	Time				Brg. check	Brg. correction		
1						T□□□ B□□□										
2						T□□□ B□□□										
3						T□□□ B□□□										

Table 4.1 Fits of the metric design four-row tapered roller bearing to the roll neck

Units: μm

Nominal bore diameter d (mm)		Single plane mean bore diameter deviation Δdmp		Tolerance for roll neck diameter		Clearances		Wear limit of roll neck (reference)
over	incl	high	low	high	low	min.	max.	
80	120	0	-20	-120	-150	100	150	300
120	180	0	-25	-150	-175	125	175	350
180	250	0	-30	-175	-200	145	200	400
250	315	0	-35	-210	-250	175	250	500
315	400	0	-40	-240	-300	200	300	600
400	500	0	-45	-245	-300	200	300	600
500	630	0	-50	-250	-300	200	300	600
630	800	0	-75	-325	-400	250	400	800
800	1000	0	-100	-375	-450	275	450	900
1000	1250	0	-125	-425	-500	300	500	1000
1250	1600	0	-160	-510	-600	350	600	1200

Table 4.2 Fits of the metric design four-row tapered roller bearing to the chock

Units: μm

Nominal outside diameter D (mm)		Single plane mean outside diameter deviation ΔDmp		Tolerance for chock diameter		Clearances		Wear limit of chock (reference)
over	incl	high	low	high	low	min.	max.	
120	150	0	-18	+57	+25	25	75	150
150	180	0	-25	+100	+50	50	125	250
180	250	0	-30	+120	+50	50	150	300
250	315	0	-35	+115	+50	50	150	300
305	400	0	-40	+110	+50	50	150	300
400	500	0	-45	+105	+50	50	150	300
500	630	0	-50	+100	+50	50	150	300
630	800	0	-75	+150	+75	75	225	450
800	1000	0	-100	+150	+75	75	250	500
1000	1250	0	-125	+175	+100	100	300	600
1250	1600	0	-160	+215	+125	125	375	750
1600	2000	0	-200	+250	+150	150	450	900

Table 4.3 Fits of the inch design four-row tapered roller bearing to the roll neck

Units: μm

Nominal bore diameter d (mm)				Bore diameter deviation Δd_s		Tolerance for roll neck diameter		Clearances		Wear limit of roll neck (reference)
over		incl		high	low	high	low	high	low	
(mm)	(inch)	(mm)	(inch)							
101,600	4.0000	127,000	5.0000	+ 25	0	- 100	- 125	100	150	300
127,000	5.0000	152,400	6.0000	+ 25	0	- 125	- 150	125	175	350
152,400	6.0000	203,200	8.0000	+ 25	0	- 150	- 175	150	200	400
203,200	8.0000	304,800	12.0000	+ 25	0	- 175	- 200	175	225	450
304,800	12.0000	609,600	24.0000	+ 51	0	- 200	- 250	200	301	600
609,600	24.0000	914,400	36.0000	+ 76	0	- 250	- 325	250	401	800
914,400	36.0000	1219,200	48.0000	+ 102	0	- 300	- 400	300	502	1000
1219,200	48.0000	-	-	+ 127	0	- 375	- 475	375	602	1200
800	1000			0	-100	-375	-450	275	450	900
1000	1250			0	-125	-425	-500	300	500	1000
1250	1600			0	-160	-510	-600	350	600	1200

Table 4.4 Fits of the inch design four-row tapered roller bearing to the chock

Units: μm

Nominal outside diameter D (mm)				Outside diameter deviation ΔD_s		Tolerance for chock diameter		Clearances		Wear limit of chock (reference)
over		incl		high	low	high	low	high	low	
(mm)	(inch)	(mm)	(inch)							
-	-	304,800	12.0000	+ 25	0	+ 75	+ 50	25	75	150
304,800	12.0000	609,600	24.0000	+ 51	0	+ 150	+ 100	49	150	300
609,600	24.0000	914,400	36.0000	+ 76	0	+ 225	+ 150	74	225	450
914,400	36.0000	1219,200	48.0000	+ 102	0	+ 300	+ 200	98	300	600
1219,200	48.0000	1524,000	60.0000	+ 127	0	+ 375	+ 250	123	375	750
1524,000	50.0000	-	-	+ 157	0	+ 450	+ 300	143	450	900

Table 4.5 Recommended fitting of four-row cylindrical roller bearing using shrink-fit inner ring

Units: μm

Nominal bore diameter d, or outside diameter D (mm)		Tolerance for roll neck diameter (tolerance class)		Tolerance for chock bore diameter (G7)	
over	incl	high	low	high	low
80	120	+ 45	+ 23(r6)	-	-
120	140	+ 52	+ 27(r6)	+ 54	+ 14
140	180	+ 68	+ 43(p6)	+ 54	+ 14
180	200	+ 79	+ 50(p6)	+ 61	+ 15
200	225	+ 109	+ 80(r6)	+ 61	+ 15
225	250	+ 113	+ 84(r6)	+ 61	+ 15
250	280	+ 126	+ 94(r6)	+ 69	+ 17
280	305	+ 165	+ 130	+ 69	+ 17
315	355	+ 165	+ 130	+ 75	+ 18
355	400	+ 190	+ 150	+ 75	+ 18
400	450	+ 220	+ 170	+ 83	+ 20
450	500	+ 250	+ 190	+ 83	+ 20
500	560	+ 280	+ 210	+ 92	+ 22
560	630	+ 320	+ 250	+ 92	+ 22
630	710	+ 350	+ 270	+ 104	+ 24
710	800	+ 390	+ 310	+ 104	+ 24
800	900	+ 440	+ 350	+ 116	+ 26
900	1000	+ 480	+ 390	+ 116	+ 26
1000	1250	+ 530	+ 430	+ 133	+ 28
1250	1600	-	-	+ 155	+ 30

5. Lubrication

5.1 Purpose and effect

The purpose of lubrication is to reduce friction and wear inside the bearing and thus to prevent seizure. Effects of the lubrication are described below:

1. Reduction in the wear and friction
To prevent contact between metals and to reduce friction and wear by forming a protective oil film over the mutual contact portion of the bearing ring, rolling element, and cage.
2. Removal of the frictional heat and cooling
To remove the heat generated through friction or heat transmitted from the outside and to cool the bearing by oil, preventing overheating of the bearing and degradation of the lubricating oil, by means of the circulating oil method.
3. Extension of contact fatigue life
To extend the rolling contact fatigue life of a bearing, by forming a sufficiently thick oil film over the rotating rolling contact surface. Lubrication can also prevent entry of foreign materials into the bearing and prevent rusting or corrosion.

5.2 Lubrication method

The rolling bearing lubrication method is accomplished either with grease or oil. Merits and demerits are compared in Table 5.1. Selection of the lubrication method most appropriate to the operation conditions and purpose of the bearing is most important for the bearing to demonstrate its highest performance.

Table 5.1 Merits and demerits of grease and oil lubrication

Item	Grease lubrication	Oil lubrication
Housing sealing system	Simplification possible in general	Slightly complicated, Requires careful maintenance
Speed	Applicable when the speed is medium or below	Applicable even when the speed is high
Cooling effect	None	Effective heat removal (circulating lubrication)
Removal of dust and water	Difficult	Possible (circulating lubrication)
Nearby mechanical devices can share a common lubrication system	Difficult	Easy
Maintenance	Easy	Requires checks at short intervals because of oil leakage, etc.

5.2.1 Grease lubrication

Generally speaking, grease lubrication is a convenient way of lubrication as the seal unit becomes simplified. Namely, once the grease is filled, no more supply is necessary for a considerably long time. Actually, a bearing filled with grease is used as it is (sealing method), an adequate amount of grease is filled in a housing and replenished or changed after a given interval (grease filling method), or grease supply is provided by a centralized manner (centralized greasing method).

Recently, with the grease itself being improved, its application field has expanded. But it is still necessary to select the best grease and lubrication method while considering the speed, operating temperature, grease filling rate, and grease life. For a roll neck bearing, the lubrication practice employed frequently nowadays is to use a grease filling method, not the centralized lubrication method, so as to shorten the time necessary for the roll exchange procedure. It is particularly necessary to establish a work standard with due consideration of the reliability of the seal unit, grease characteristics, and grease supply amount in the roll shop.

1. Grease filling amount in the housing (chock)
The amount of grease to be filled into the housing (chock) varies depending on the housing (chock) construction, space volume, and atmosphere. The general guideline is described below. First, fill a sufficient amount of grease into the bearing, then depending on the speed range fill the grease amount (shown in Table 5.2) into the space (excluding the shaft and bearing in the chock)

Table 5.2 Grease filling amount

Rotating conditions	Ratio for the space volume	Remarks
From extremely low to low speeds	2/3 ~ 1	Including prevention of water entry at low speed
Low to medium speeds	1/2 ~ 2/3	Applications at general speeds
Medium to high speeds	1/3 ~ 1/2	Small filling amount for high speed applications

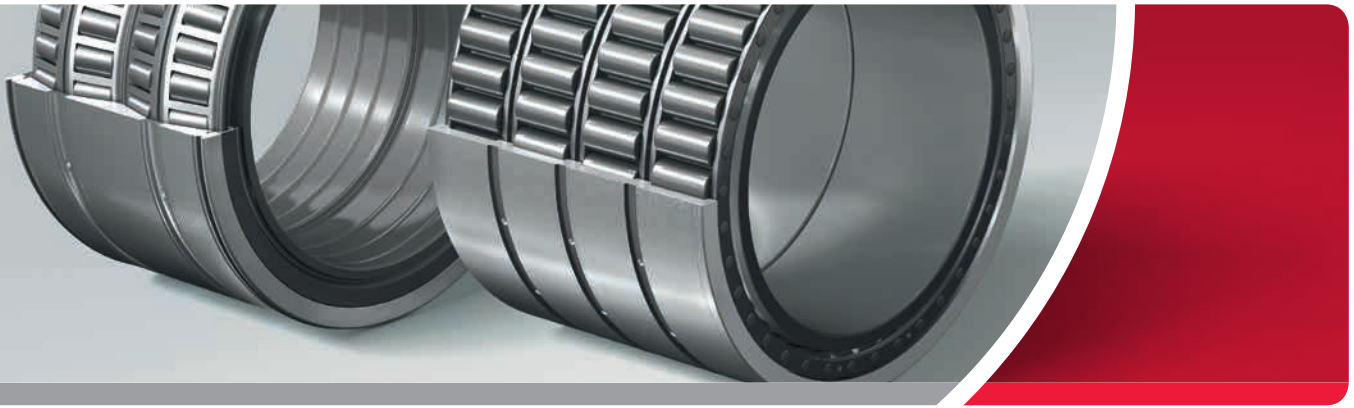

2. Grease supply

Generally speaking, once filled, grease need not be added for a long time. Depending on the operation conditions, however, frequent grease supply or change may become necessary. Due attention must be paid to this point when designing the housing. In blooming or shape steel rolling mills with centralized lubrication of the roll neck bearing, the specified amount of grease is supplied at a set interval. When the grease filling method is employed as in the case of the roll neck bearing of a cold rolling mill, new grease is added until the old grease is pushed out slightly from the seal. The cycle of disassembly and cleaning of the sealed bearing, namely grease change, varies depending on operation and actual rolling conditions and thus cannot be set to a standard interval. In practice, determine the typical disassembly and cleaning interval schedule by checking its state periodically for about one year after initial start-up.

Typical disassembly/cleaning interval

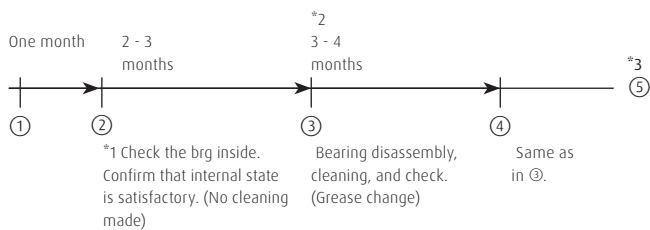

- *1. Add a new grease amount equal to the lost amount during inspection.
- *2. This interval is determined from the inspection results of ③. If damage or wear of seals or O-rings is observed during an inspection of a sealed bearing (Section 4.2), replace it with a new one. Though the replacement interval varies depending on operating conditions, it is decided based on the conditions when checked. It is usually around 6 months.
- *3. Final disassembly/cleaning interval ⑤ is determined on the basis of the inspection result of ④. Generally, the recommended interval of disassembly for the sealed bearing of the roll neck is about 3 to 6 months though this may vary depending on the operation conditions.

5.2.2 Oil lubrication

1. Forced oil circulation lubrication

For high-speed or high ambient-temperature applications, cooling of the bearing with oil is necessary. Forced oil circulation lubrication is the method used most frequently. In this method, the oil returns to the tank via drain pipe after lubrication and cooling of the bearing's inside, then the oil is cooled, filtered, and forced to circulate for lubrication again by a pump. The drain pipe size is normally two times or more larger than that of the supply pipe to prevent overfilling of the lubricant. The guideline for the required supply amount for forced lubrication is determined as follows:

$$Q \cong \frac{1.89 \times 10^{-6}}{T_2 - T_1} d \cdot \mu \cdot n \cdot F \text{ (N)} \quad (5.1)$$

$$Q \cong \frac{1.85 \times 10^{-5}}{T_2 - T_1} d \cdot \mu \cdot n \cdot F \text{ {kgf}} \quad (5.1)$$

where,

- Q : Oil supply rate (liters/min)
- T_1 : Oil temperature at oil inlet (°C)
- T_2 : Oil temperature at oil outlet (°C)
- d : Bearing bore (mm)
- n : Bearing speed (min⁻¹)
- F : Load on the bearing (N) {kgf}
- μ : Dynamic friction coefficient of bearing

Bearing type	Approximate value of μ
Cylindrical roller bearing	0.001
Tapered roller bearing	0.002

Using the value thus calculated and considering the limit due to the size of the oil supply and drain ports, an adequate supply amount is determined. For a large bearing (bore to exceed 200 mm) subject to heavy load, the oil amount determined with equation (5.1) may be too large. The recommended value would be 2/3 to 1/2 of the amount.

5. Lubrication

2. Oil mist lubrication method

The mist oil from the oil mist generator is fed to the lubrication point via piping and sprayed in a form of readily adhering particles from a fitting (nozzle) in the housing or bearing. Oil mist lubrication method has the following advantages:

- › More suitable for applications with higher speed than oil bath lubrication
- › High viscosity oil can be used, with thick oil film formed. This is advantageous against seizure and promotes a longer bearing fatigue life.
- › Only the minimum required amount of new oil is constantly supplied, effectively lubricating the bearing with a minimum of oil consumption.
- › Oil stains on machinery and product are less than in the case of grease lubrication. After disassembly, cleaning of parts is easier.

a) Determining the mist amount

The air-oil mist amount can be calculated as follows:

$$Q_m \cong A \cdot d \cdot R \quad (5.2)$$

where,

Q_m : Mist amount (ft³/min)

A : Factor (for rolling mill, nominal speed $A = 0.05$)

d : Bearing bore (inch)

R : No. of rows of rolling elements

For high speed applications, value of Q_m is increased by two or four times.

b) Mist flow rate in piping

The size of the distribution pipe to feed the required mist amount to each fitting must be one at which the mist flow rate in the piping becomes 5 m/sec or less. Higher flow rates may cause excessive condensation of mist in the distribution pipe, causing uneven mist supply and a partial deficiency.

c) Fitting installation position

The fitting is installed near the bore of the housing (chock) or to the outer ring of the bearing. The latter is used particularly for backup roll bearings of high speeds. In the case of the work roll neck bearing of a rolling mill with a high rolling load, the nozzle may be installed directly to the outer ring spacer.

d) Vent

The vent is an important element to keep the oil volume in the housing constant and to keep a satisfactory flow of mist in the bearing. Normally, the vent is provided in a position to enable the oil level to be maintained at a height which is equal to about the middle of the bottom rolling element.

e) Selection of the mist oil to be used

The mist oil to be used must be a high-grade lubricating oil with extreme pressure performance and oxidation stability. This oil must also be readily misted. It is also desirable that the oil can be re-coagulated readily after passing through the fitting. A lubricating oil dedicated for oil mist use (satisfies all these requirements) can be found in the market. The oil viscosity varies depending on the operation conditions, but is generally 330 - 430 mm²/s {cSt} at 40°C for roll neck bearings of rolling mills.

f) Operation conditions of a mist generator

General conditions are described below:

Pressure distribution in pipe :500 mm in water column

Heating air temperature :65-80°C

Oil temperature :50°C

When a large bearing is used at high speed and is to be lubricated with mist, the effectiveness of such lubrication varies depending on the construction around the bearing. Please consult NSK.

3. Oil-air lubrication

Features of an oil-air lubrication system

- › Correct and stable oil supply at the set amount to the bearing, without being affected by the temperature change of lubricating oil and compressed air and pressure change in the piping.

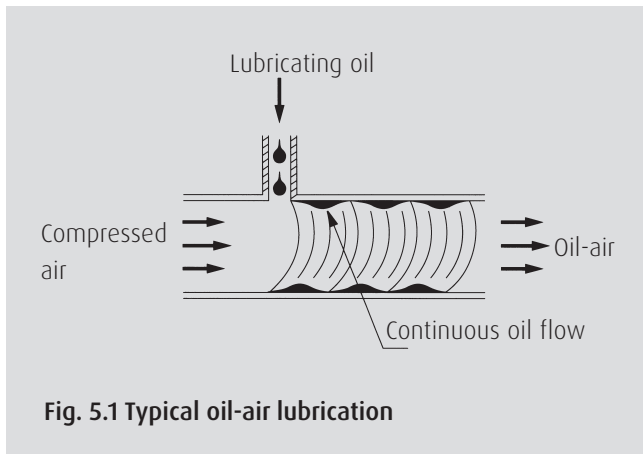

Fig. 5.1 Typical oil-air lubrication

- › Substantial savings in oil consumption.
A high-performance distributor in the oil-air system ensures correct supply of the lubrication oil to the bearing, which in turn makes it easy to determine the supply amount to each point beforehand. As a result, only the minimum required amount of oil is necessary, contributing to a reduction of the oil consumption, to about 1/10 that of oil-mist lubrication. The lubrication oil consumption can be saved greatly by this method.

Required oil quantity Q can be calculated as follows:

$$Q \cong A \cdot D \cdot B \text{ (ml/h)} \quad (6.1)$$

where,

A : Coefficient (Generally $A = 0.00003$, but it may change depending on the operating conditions.)

D : Bearing outside diameter (mm)

B : Bearing width (mm)

- › Prevention of foreign materials from entering the bearing by means of pneumatic pressure in the housing. Since the compressed air is normally supplied along with the oil into the housing, the sealing function is enhanced, thereby preventing entry of water and scale from the outside. The result is an ideal bearing operation state, with the bearing life extended substantially.
- › Easy piping
Oil-air lubrication is made by using compressed air to supply the oil. There is no influence caused by the direction of piping.
- › Multi-branching distribution of oil-air
Most systems now enable correct distribution of the oil-air to multiple lubrication points (patent pending). The piping system is therefore simplified, ensuring easy maintenance.
- › Clean environment around machinery
Since the oil-air lubrication supplies the minimum required set amount of oil, the oil collected in the housing can be recovered periodically through the drain port. The equipment's environment can therefore be maintained in a cleaner condition.



NSK AMERICAS

United States
NSK Corporation
Ann Arbor MI
1.888.446.5675

Canada
NSK Canada Inc.
Mississauga ON
1.888.603.7667

Mexico
NSK Rodamientos Mexicana,
S.A. de C.V.
Silao Guanajuato MX
52.472.500.9500

Brazil
NSK Brasil Ltda.
Suzano SP
55.11.4744.2500

Argentina
NSK Argentina SRL
Buenos Aires
54.11.4704.5100

Latin America
NSK Latin America Inc.
Miramar FL
1.305.477.0605

Website: www.nskamericas.com
NSK Global: www.nsk.com

Every care has been taken to ensure the accuracy of the data contained in this brochure, but no liability can be accepted for any loss or damage suffered through errors or omissions.

Printed in the USA ©NSK 2022.
The contents of the publication are the copyright of the publishers.