



BEARING MAINTENANCE GUIDE

MOUNTING AND HANDLING PRACTICES FOR OPERATIONAL RELIABILITY



NSK TECHNICAL SERVICES



BEARING MAINTENANCE GUIDE

Every care has been taken to ensure the accuracy of the data contained in this catalog, but no liability can be accepted for any loss or damage suffered through errors or omissions.

Printed in the USA ©NSK 2025. The contents of the publication are the copyright of the publishers.

BMG v3 / ACAT / 25

Website: www.nsk.com/am-en

NSK Global: www.nsk.com

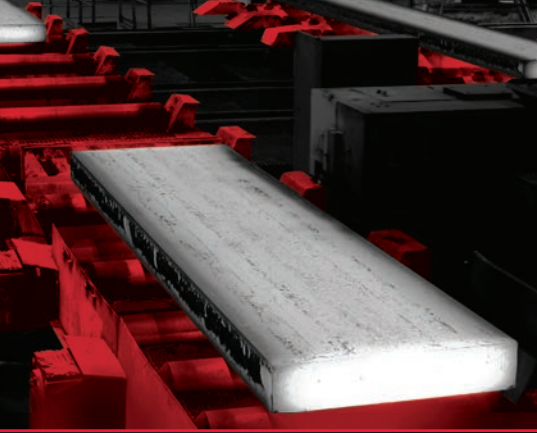

A GLOBAL PARTNER AND SOLUTIONS PROVIDER

As a leading manufacturer of rolling bearings and linear technology components, NSK can be found on almost every continent - with production facilities, sales offices and technology centers - providing our customers with responsive design and decision-making, effective logistics and dedicated local service.

CONTENTS

- A BEARING TYPES AND CHARACTERISTICS
- B MOUNTING AND DISMOUNTING
- C SHAFT AND HOUSING FITS
- D LUBRICATION
- E TROUBLESHOOTING / BEARING DAMAGE
- F MAINTENANCE TOOLS / TECHNICAL SUPPORT



THE NSK COMPANY

NSK commenced operations as the first Japanese manufacturer of rolling bearings in 1916. From the outset, we have been continuously expanding and improving not only our product portfolio but also our range of services for various industrial sectors. In this context, we develop technologies in the fields of rolling bearings, linear systems, components for the automotive industry and mechatronic systems. Our research and production facilities in the Americas, Europe, and Asia are linked together in a global technology network. Here we concentrate not only on the development of new technologies, but also on the continuous optimization of quality – at every process stage.

At the core of our research activities is the development of advanced material and lubricant technologies, simulation applications using a variety of analytical systems, and technological innovation in the field of mechatronics.



NSKHPS

A detailed, close-up photograph of a bearing assembly, showing the inner and outer rings and the balls. The lighting is dramatic, highlighting the metallic surfaces. The text 'NSKHPS' is visible on the inner ring.

SECTION A:

BEARING TYPES AND CHARACTERISTICS

COMMON BEARING TYPES AND COMPONENTS	A3
ROLLING BEARING TYPES AND CHARACTERISTICS	A5
Load Capacity and Bearing Types	A7
Permissible Speed and Bearing Types	A7
Misalignment of Inner/Outer Rings	A8
Rigidity	A8
Noise and Torque	A8
Running Accuracy and Bearing Types	A8
BALL BEARING TYPES	A9
ROLLER BEARING TYPES	A11
PILLOW BLOCKS AND BEARING UNITS	A13

COMMON BEARING TYPES AND COMPONENTS

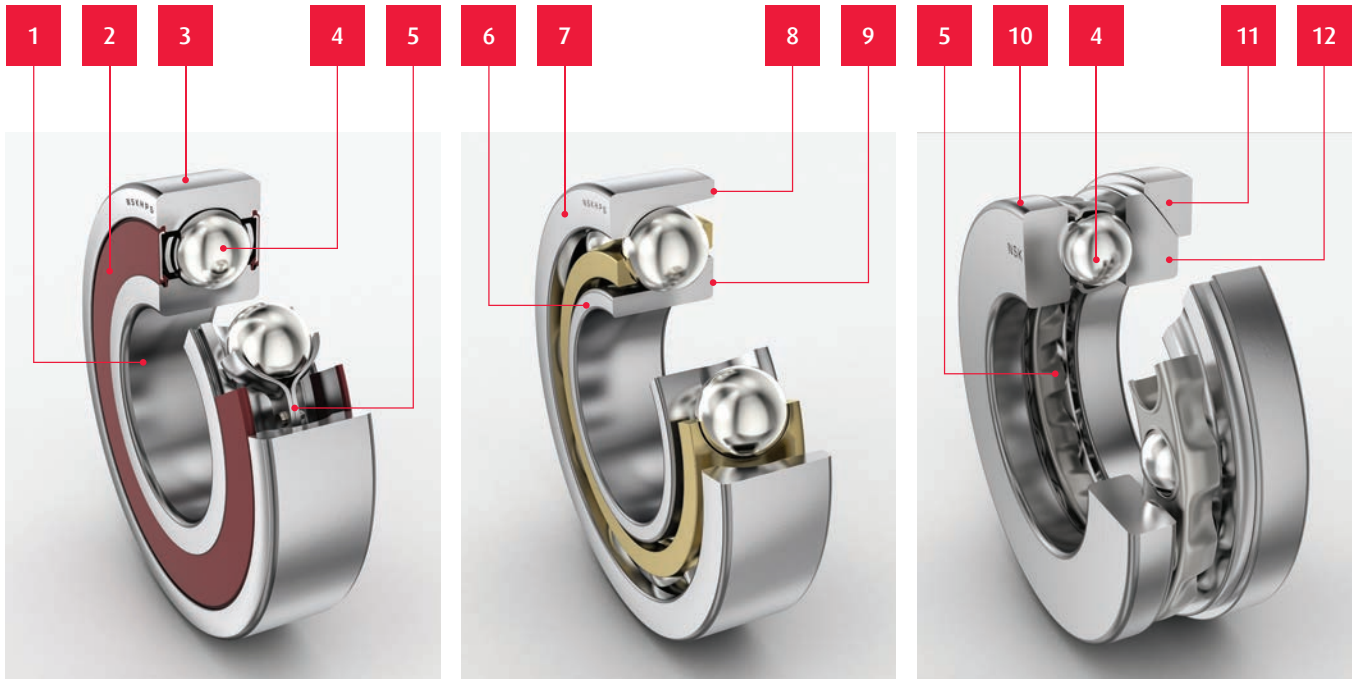

Deep groove ball bearing, sealed

Angular contact ball bearing, single row

Thrust ball bearing, single direction

ROLLING BEARING DESIGN AND CLASSIFICATION

Rolling bearings generally consist of two rings, rolling elements, and a cage, and they are classified into radial bearings or thrust bearings depending on the direction of the main load. In addition, depending on the type of rolling elements, they are classified into ball bearings or roller bearings, and they are further segregated by differences in their design or specific purpose.

A selection of representative bearing types and naming of components is shown above. A general classification of ball and roller bearing types available from NSK and an overview of their operating characteristics can be found on the pages that follow.

1	inner ring
2	seal (similarly shield)
3	outer ring
4	ball
5	cage
6	inner ring front face
7	outer ring back face
8	outer ring front face

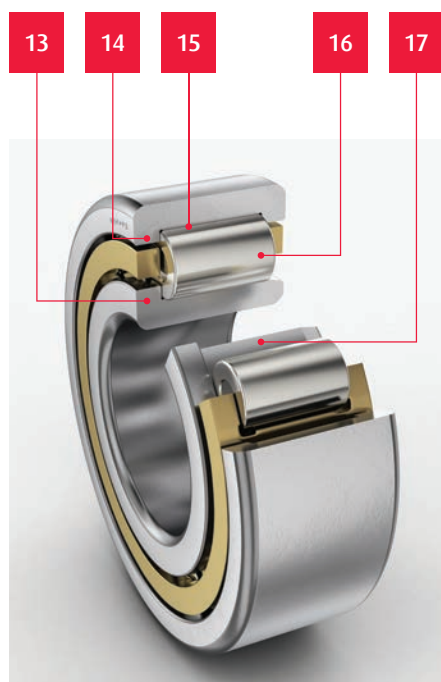

Cylindrical roller bearing, single row



Spherical roller bearing





Tapered roller bearing, single row

9	inner ring back face
10	shaft washer
11	housing washer
12	aligning seat washer
13	inner ring flange
14	outer ring flange
15	outer ring raceway
16	cylindrical roller

17	inner ring raceway
18	spherical roller
19	lubrication feature - groove, holes
20	cone front face flange
21	cup
22	tapered roller
23	cone back face flange
24	cone

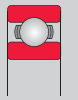
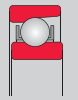
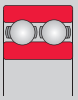
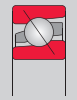
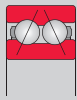
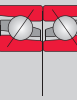
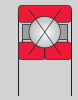
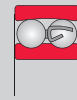
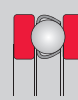
ROLLING BEARING TYPES AND CHARACTERISTICS

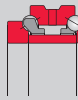
BEARING TYPE		DEEP GROOVE BALL BEARINGS			ANGULAR CONTACT BALL BEARINGS				SELF-ALIGNING BALL BEARINGS	THRUST BALL BEARINGS		
		Single row	Magneto	Double row	Single row	Double row	Duplex	Four-point		with flat seat	with aligning seat	Double direction thrust
CHARACTERISTICS												
Load Capacity	Radial	fair	poor	good	good	good	good	poor	fair	not possible	not possible	not possible
	Axial	fair - two directions	poor - one direction only	fair - two directions	good - one direction only	good - two directions	good - two directions	good - two directions	poor - two directions	good - one direction only	good - one direction only	good - two directions
	Combined	fair	poor	fair	good	good	good	fair	poor	not possible	not possible	not possible
High Speeds		excellent	good	fair	excellent	fair	good	good	good	not possible	not possible	fair
High Accuracy		excellent			excellent		excellent	good		good		excellent
Rigidity							good					good
Angular Misalignment		good	poor	poor	poor	poor	poor	poor	excellent	not possible	excellent	not possible
Self-aligning Capability									●		●	
Ring Separability			●							●	●	●
Fixed-end Bearing		●				●	●	●	●			
Free-end Bearing		○				○	○	○	○			
Tapered Bore Option									●			
Remarks			Two bearings are usually mounted in opposition		Contact angles of 15, 25, 30 and 40° Two bearings are usually mounted in opposition Clearance adjustment is necessary	Contact angles of 25, 30 and 32°	DF and DT combinations cannot be used as free-end bearings	Contact angle of 35°				

SPHERICAL ROLLER BEARINGS	CYLINDRICAL ROLLER BEARINGS				TAPERED ROLLER BEARINGS		NEEDLE ROLLER BEARINGS	THRUST ROLLER BEARINGS			BEARING TYPE	
	Single Row	with inner ring rib	with thrust collar	Double Row	Single Row	Double / multi-row		Spherical	Cylindrical	Tapered		
											CHARACTERISTICS	
excellent	good	good	good	excellent	good	excellent	good	poor	not possible	not possible	Radial	Load Capacity
fair - two directions	not possible	fair - one direction only	fair - two directions	not possible	good - one direction only	good - two directions	not possible	excellent - one direction only	excellent - one direction only	excellent - one direction only	Axial	
good	not possible	fair	fair	not possible	good	excellent	not possible	poor	not possible	not possible	Combined	
fair	excellent	good	good	good	fair	fair	good	poor	poor	poor	High Speeds	
	excellent			excellent	good						High Accuracy	
	good	good	good	excellent	good	excellent	good		excellent	excellent	Rigidity	
excellent	fair	fair	fair	poor	fair	poor	poor	excellent	not possible	not possible	Angular Misalignment	
●								●			Self-aligning Capability	
	●	●	●	●	●	●	●	●	●	●	Ring Separability	
●			●			●					Fixed-end Bearing	
○	●			●		○	●				Free-end Bearing	
●				●							Tapered Bore Option	
	Inclusive of NU and N types	Inclusive of NJ and NF types	Inclusive of NH and NUP types	Inclusive of NN and NNU types	Two bearings are usually mounted in opposition Clearance adjustment is necessary	KH and KV types cannot be used as free-end bearings			Including needle roller thrust bearings		Remarks	

● applicable ○ applicable, but it is necessary to allow shaft contraction / elongation at fitting surfaces

COMMON BEARING TYPES AND COMPONENTS

LOAD CAPACITY AND BEARING TYPES

Depending upon the application, rolling bearings may be subjected to the various types of loads listed below:

- › Radial load
- › Axial load
- › Combined radial and axial loads
- › Moment loads

When considering bearing selection, it is critical that the bearing type possesses performance characteristics suited to the type and magnitude of the load. The axial load carrying capacity of a bearing is closely related to the radial load capacity in a manner that depends on the bearing type as shown in **Figure 1**. When bearings of the same dimension series are compared, roller bearings have a higher load capacity than ball bearings and are superior if shock loads exist.

PERMISSIBLE SPEED AND BEARING TYPES

The maximum speed of rolling bearings varies depending, not only the type of bearing, but also its size, type of cage, loads, lubricating method, heat dissipation, etc. Using the assumption of employing a common oil bath lubrication method, the relative speed characteristics for common bearing types are approximately ranked in **Figure 2**.

Fig. 1 - Relative Load Capacities of Bearing Types

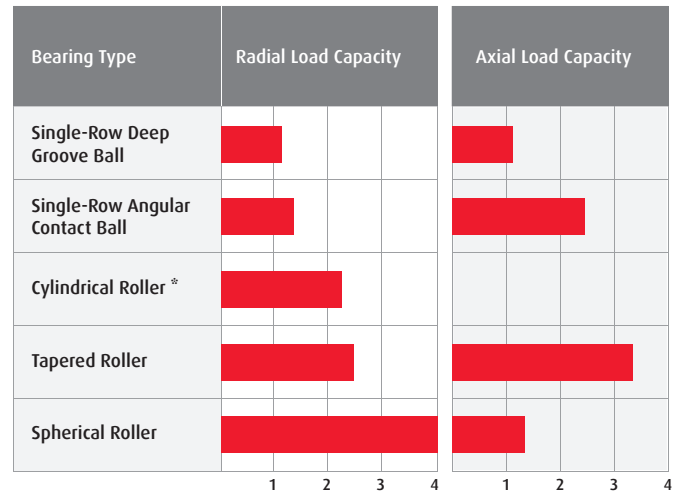
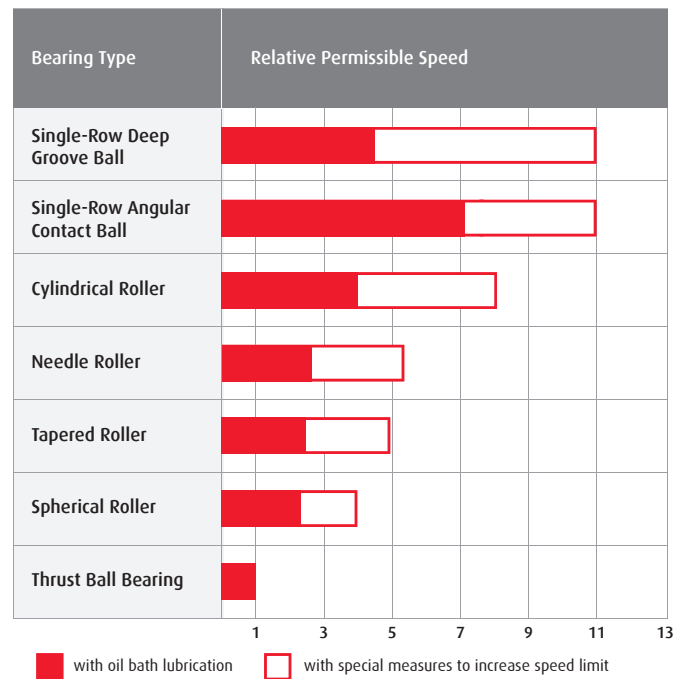

Fig. 2 - Relative Permissible Speeds of Bearing Types



MISALIGNMENT OF INNER/OUTER RINGS

Because of deflection of a shaft caused by applied loads, dimensional error of the shaft and housing, and mounting errors, the inner and outer rings are slightly misaligned. The permissible misalignment varies depending on the bearing type and operating conditions, but usually it is a small angle less than 0.0012 radian (4 minutes). When the misalignment is expected to be greater than this value, bearings having a self-aligning capability, such as self-aligning ball bearings, spherical roller bearings, and certain bearing units, should be selected.

RIGIDITY

When loads are imposed on a rolling bearing, some elastic deformation occurs in the contact areas between the rolling elements and raceways. The rigidity of the bearing is determined by the ratio of bearing load to the amount of elastic deformation of the inner and outer rings and rolling elements. Consequently, since roller bearings are deformed less by load, they are more often selected than ball bearings. When extra high rigidity is required, bearings are given a preload, which means that they have a negative clearance. Angular contact ball bearings and tapered roller bearings are sometimes preloaded.

NOISE AND TORQUE

Since rolling bearings are manufactured with very high precision, noise and torque are minimal. For deep groove ball bearings and cylindrical roller bearings particularly, the noise level is sometimes specified depending on their purpose. For high precision miniature ball bearings, the starting torque is specified. Deep groove ball bearings are typically recommended for applications in which low noise and torque are required, such as motors and instruments.

Fig. 3 - Relative Inner Ring Radial Runout of Highest Accuracy Class of Bearing Types

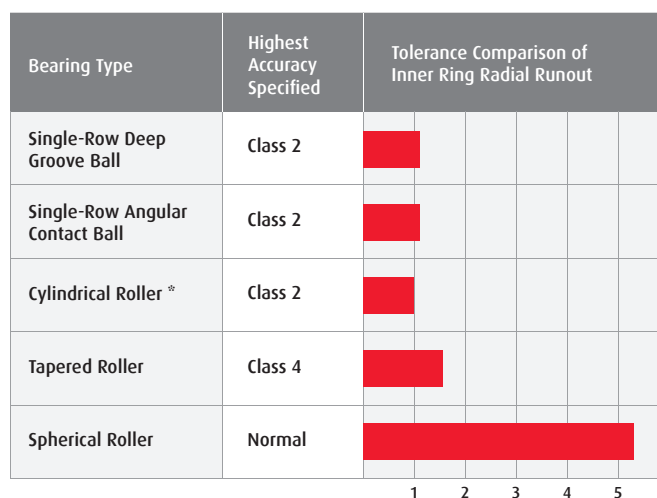

RUNNING ACCURACY AND BEARING TYPES

The running accuracy of rolling bearings is specified in various ways, and the specified accuracy classes vary depending on the bearing type. For applications that require high running accuracy or high speeds, high precision bearings of Class 5, 4 or 2 are used. For comparison purposes, inner ring radial runout for the highest running accuracy specified for common bearing types is shown in **Figure 3**. Deep groove and angular contact ball bearings and cylindrical roller bearings are most suitable for applications requiring high running accuracy.

BALL BEARING TYPES



DEEP GROOVE BALL BEARINGS

Single Row (4.1)

- › open, with contact seals, non-contact seals, shields
- › with a snap ring groove, with or without a snap ring

Max Type with filling slot (4.2)

- › open, with shields

Magneto type (4.3)

Creep-Free™ type (4.4)

- › open, with contact seals, shields

Double Row

ANGULAR CONTACT BALL BEARINGS

Single Row (4.5)

- › for single mounting or universal matching
- › with 15°, 25°, 30° or 40° contact angle

Single Row, high precision

- › for single mounting or universal matching
- › in duplex, triplex and quadruplex sets (4.6)
- › with non-contact seal (4.7)
- › with 15°, 25° or 30° contact angle

Single Row Ultra High-Speed, high precision

- › for single mounting or universal matching
- › in duplex, triplex and quadruplex sets
- › with non-contact seal
- › with 18° or 25° contact angle

Double Row (4.8)

- › open, with contact seals, non-contact seals, shields
- › with a snap ring groove, with or without a snap ring
- › with 25° or 32° contact angle

Four-Point contact (4.9)

SELF-ALIGNING BALL BEARINGS

- › with a cylindrical or tapered bore (4.10)
- › open, with contact seals
- › with an extended inner ring

THRUST BALL BEARINGS

Single Direction

- › with flat seat (4.11)
- › with aligning seat, with or without aligning seat washer (4.12)

Double Direction

- › with flat seat (4.13)
- › with aligning seat, with or without aligning seat washer (4.14)

ANGULAR CONTACT THRUST BALL BEARINGS

Single Row (Direction), high precision (4.15)

- › for single mounting or universal matching
- › in duplex, triplex and quadruplex sets
- › with 30° or 40° contact angle

Single Direction, high precision (4.16)

- › for universal matching
- › with 50° contact angle

Double Direction, high precision (4.17)

- › with 60° contact angle

ANGULAR CONTACT BALL SCREW SUPPORT BEARINGS

Single Row, high precision (4.18)

- › for single mounting or universal matching
- › open, with contact seals
- › with 60° contact angle

Double Row, high precision

- › for single mounting or universal matching
- › with contact seals
- › for housing (4.19) or direct face-mounting (4.20)
- › with 60° contact angle

Fig. 4 - Ball Bearing Types

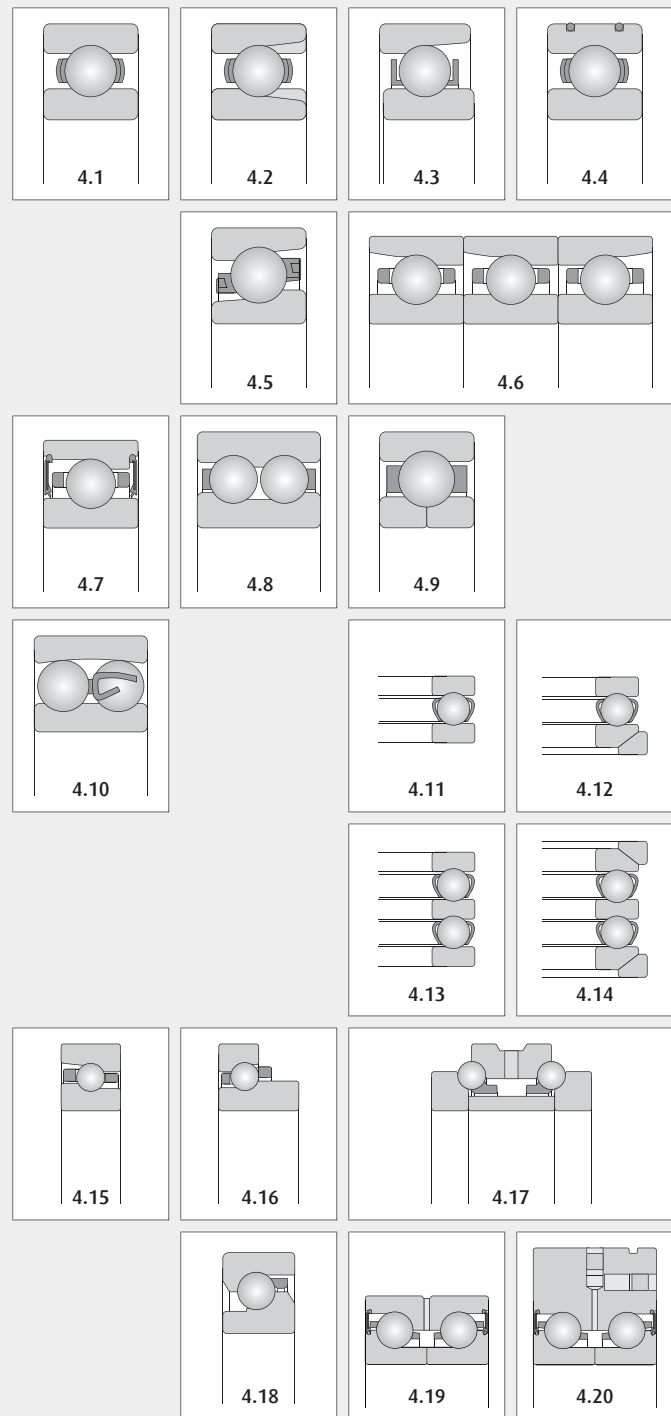

ROLLER BEARING TYPES



SPHERICAL ROLLER BEARINGS

Open type (5.1)

- › with cylindrical or tapered bore

With integral contact seal (5.2)

- › with cylindrical or tapered bore

With removable seal (5.3)

- › with cylindrical or tapered bore

CYLINDRICAL ROLLER BEARINGS

Single Row

- › NU type - no flange on inner ring (5.4)
- › NJ type - one flange on inner ring (5.5)
- › N type - no flange on outer ring (5.6)
- › NF type - one flange on outer ring (5.7)
- › NUP type - one flange on inner ring + locating ring (5.8)
- › NH type - one flange on inner ring + thrust collar (5.9)

CYLINDRICAL ROLLER BEARINGS

Double Row, cylindrical or tapered bore

- › NNU type - no flange on inner ring (5.10)
- › NN type - no flange on outer ring (5.11)

Four-Row (5.12)

- › with cylindrical or tapered bore
- › with or without inner / outer ring flanges

FULL COMPLEMENT CYLINDRICAL ROLLER BEARINGS

Single Row

- › NCF type - flanges on inner ring + retaining ring (5.13)

Double Row

- › NNCF type - flanges on inner ring + retaining ring (5.14)
- › crane sheave type - corrosion resistant, lubricating features, closures and snap rings

NEEDLE ROLLER BEARINGS DRAWN CUP NEEDLE ROLLER BEARINGS (5.15)

- › solid needle roller bearings (5.16)
- › cage and roller assemblies (5.17)
- › thrust needle roller bearings
- › cam followers
- › roller followers (5.18)
- › components

TAPERED ROLLER BEARINGS

Single Row (5.19)

- › for single mounting or duplex arrangement

Double Row

- › double cup / single cone - TDO configuration (5.20)
- › double cone / single cup - TDI configuration
- › with normal or steep angle

Four Row

- › KV type - TQO configuration
- › KVE / KVS type - KV sealed-clean design (5.21)

ROLLER THRUST BEARINGS

Spherical Roller Thrust Bearings (5.22)

- › single direction

Cylindrical Roller Thrust Bearings (5.23)

- › single direction

Tapered Roller Thrust Bearings

- › single direction (5.24)
- › double direction

CROSSED ROLLER BEARINGS (5.25)

Fig. 5 - Roller Bearing Types

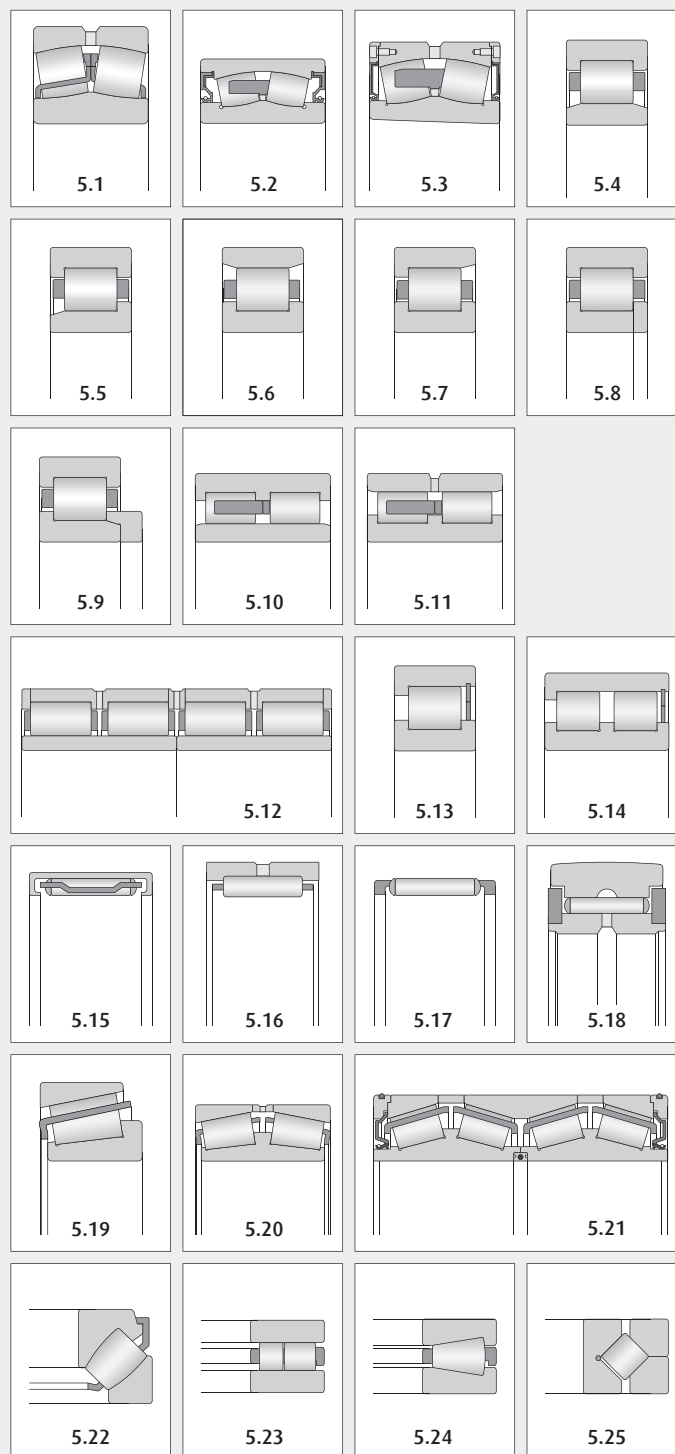

PILLOW BLOCKS AND BEARING UNITS

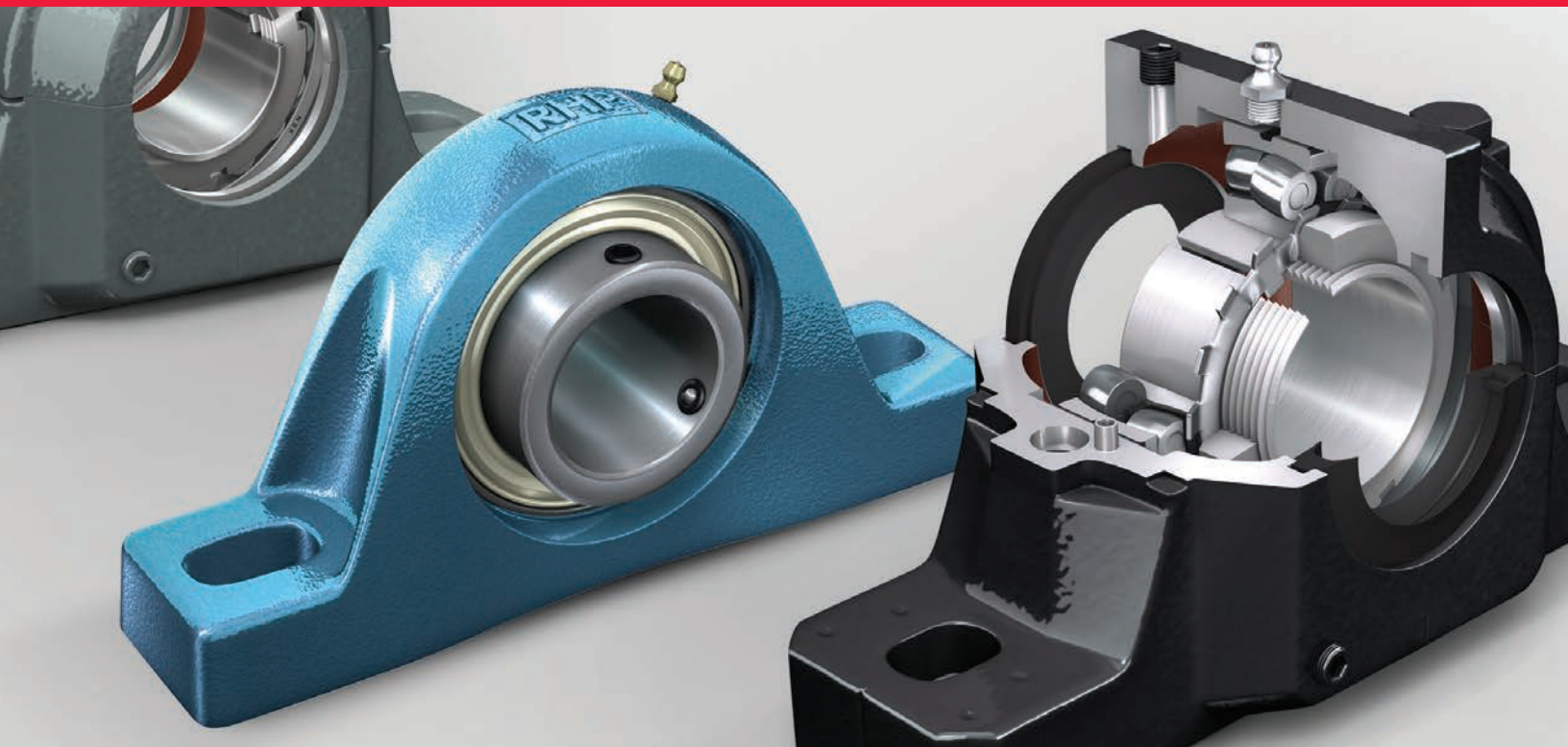

SPLIT PILLOW BLOCKS

SAF Series (6.1)

- › general duty
- › in cast iron, ductile iron and cast steel material
- › for self-aligning ball bearings or spherical roller bearings
- › with contact and non-contact triple seal rings, or special labyrinth seals for contaminated environments

SDAF Series (6.2)

- › heavy duty
- › in cast iron, ductile iron and cast steel material
- › for spherical roller bearings
- › with contact and non-contact triple seal rings, or special labyrinth seals for contaminated environments

SNN Series (6.3)

- › light to medium duty
- › in cast iron
- › for self-aligning ball bearings or spherical roller bearings
- › with contact and non-contact seal

BALL BEARING UNITS

Pillow Block Units, cast iron

- › normal base (6.4) *
- › short base (6.5)

Flange Units, cast iron

- › four bolt, square type (6.6) *
- › four bolt, round type (6.7) *
- › three bolt *
- › two bolt (6.8, 6.9) *

Cartridge Units, cast iron (6.10, 6.11)

Take-up Units, cast iron (6.12)

Belt Tensioner Units, cast iron (6.13)

Hanger Units, cast iron (6.14)

Pillow Block Units, pressed steel (6.15)

Flange Units, pressed steel

- › three bolt (6.16, 6.17)
- › two bolt (6.18)

* also available in corrosion resistant stainless steel or thermoplastic

INSERT BEARINGS

- › with set screw lock (6.19)
- › with eccentric collar lock (6.20)
- › with taper sleeve lock (6.21)
- › with single lip, flinger, triple lip seals

Fig. 6 - Pillow Blocks and Bearing Units

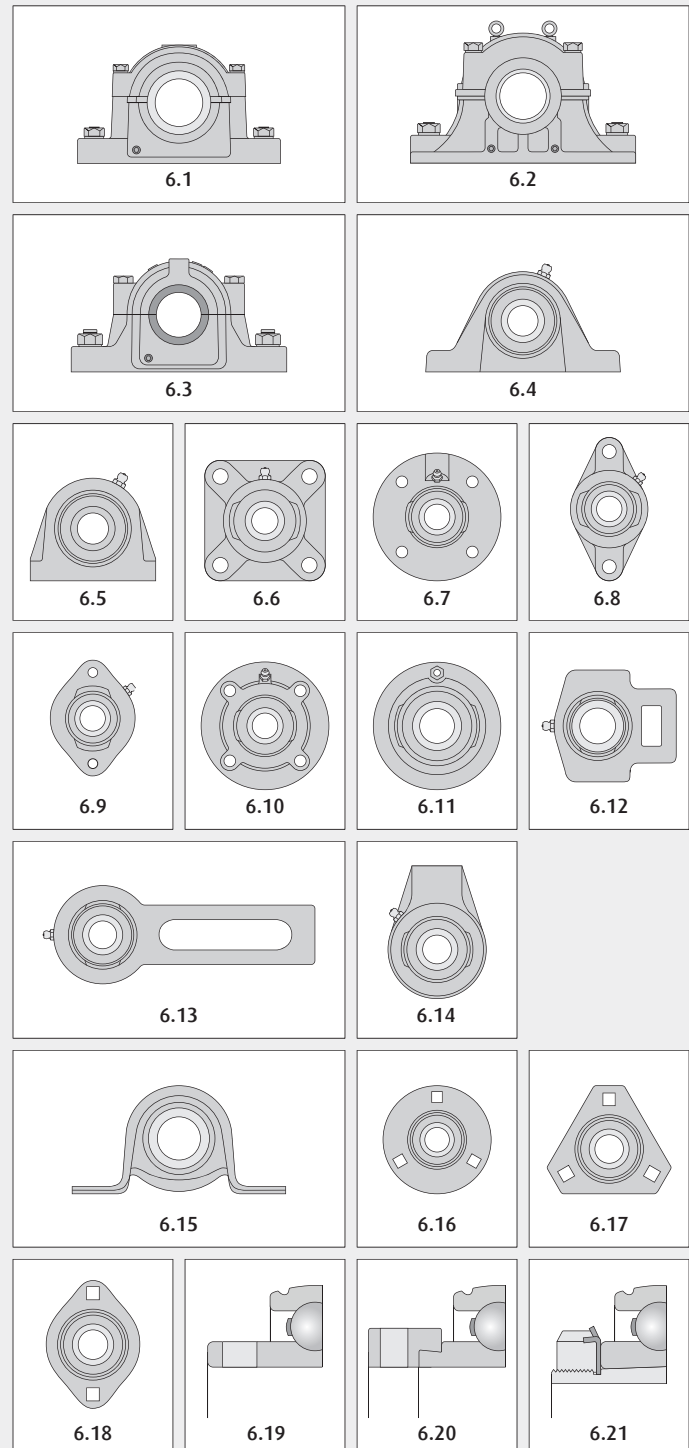



**SECTION B:
MOUNTING AND
DISMOUNTING**

GETTING STARTED	B3
Proper Handling of Bearings	B3
Bearing Storage	B4
Work Site, Tools and Equipment	B4
METHODS OF MOUNTING	B5
Selection of Mounting Methods	B5
MOUNTING BEARINGS WITH CYLINDRICAL BORES	B6
Press Fits	B6
Shrink Fits	B7
MOUNTING BEARINGS WITH TAPERED BORES	B8
Measuring Bearing Clearance	B9
Radial Clearance Reduction Method	B11
Axial Drive-up Method	B13
Angular Drive-up Method	B18
Handling of Adapter Sleeves and Lock Nuts	B19
Handling Instructions for Hydraulic Nuts	B21
MOUNTING SPHERICAL ROLLER BEARINGS WITH ADAPTER SLEEVE	B23
Lock Nut Method	B23
Hydraulic Nut Method	B25
Oil Injection Method	B27
MOUNTING SPHERICAL ROLLER BEARINGS WITH WITHDRAWAL SLEEVE	B29
Lock Nut Method	B29
Hydraulic Nut Method	B31
Oil Injection Method	B33
MOUNTING SPHERICAL ROLLER BEARINGS ON TAPERED SHAFTS	B35
Lock Nut Method	B35
Hydraulic Nut Method	B38
MOUNTING SELF-ALIGNING BALL BEARINGS	B39
MOUNTING PILLOW BLOCKS AND SEALS	B43
MOUNTING BALL BEARING UNITS	B47
METHODS OF DISMOUNTING	B49
CHECKING SHAFTS AND HOUSINGS	B51
CHECKING SLEEVES AND LOCK NUTS	B53
CHECKING DAMAGED BEARINGS	B54

MOUNTING ROLLING BEARINGS - GETTING STARTED

The approach to mounting rolling bearings warrants careful consideration as it significantly impacts their performance. Bearings are high precision components, regardless of size. To ensure optimal performance and long operating life, a high standard for handling and mounting every bearing is critical. This includes establishing a clean environment equipped with the correct tools and an understanding of the bearing's characteristics to determine the correct mounting method.

PROPER HANDLING OF BEARINGS

Since rolling bearings are high precision machine parts, they must be handled accordingly. Even if high quality bearings are used, their expected performance cannot be achieved if they are not handled properly. The main precautions to be observed are as follows:

Keep Bearings and Surrounding Area Clean

Dust and dirt have harmful effects on bearings. It is necessary to keep bearings and their environment, including worktables, handling equipment, and tools, as clean as possible. Leave the bearings in their packaging until ready to use.

Careful Handling

Dropping or mishandling the bearing can result in brinelling, cage damage, ring fracture, seal damage and other damage detrimental to the life and quiet running of the bearing.

Use Proper Tools

Always use the proper equipment when handling bearings and avoid general purpose tools.

Prevent Corrosion

Keep the bearings in the packaging until ready to use. Store in a temperature and humidity controlled room. Handle with clean, dry hands or wear gloves. Bearings should NOT be cleaned of rust preventative oil (RP) unless specifically instructed.



BEARING STORAGE

To prevent rusting, each bearing is treated and packed with an anticorrosive agent, but depending on the environment of the storing place, the effectiveness of the corrosion countermeasures varies greatly. Careful attention is necessary to select a suitable place to keep and stock replacement bearings.

General recommended practices for optimal bearing storage include:

- › Keep the bearing stored in its original packaging
- › Lay the bearing on its side
- › The storage room should be temperature controlled with variation of no more than 5 degrees F (3 degrees C)
- › The storage room should be humidity controlled with a relative humidity of less than 60% at all times
- › The storage room should be free of external vibration
- › Bearings should be stored on a shelf with appropriate load capacity at least 12 inches from the floor

Bearing Storage Duration

Storage duration is affected by the environment (temperature, humidity, vibration, etc.). The following storage times assume an appropriate environment and unopened packaging.

- › Ungreased, individually packaged bearings: up to 5 years
- › Ungreased, bulk packaged bearings: up to 3 years
- › Greased, individually packaged bearings: from 1 to 10 years depending on the grease type. Consult NSK for more details.
- › Greased, bulk packaged bearings: up to 2 years depending on the grease type. Consult NSK for more details.

WORK SITE, TOOLS AND EQUIPMENT

Select or prepare a clean work site where a working table, surface plate, cleaning tank, and bearing heater or oil heating tank are provided and where heavy material such as the bearing, sleeve, shaft, etc. can be freely and safely moved. Jigs, tools, measuring instruments and environment of work site shall always be kept clean in order to prevent introducing dust or contamination into the bearing and its operating environment.

Prior to the start of bearing mounting work, examine the steps involved in the mounting method by referring to the drawing and confirming that all necessary jigs and tools required for installation are in order. Depending on the work, preparation of a special jig may be necessary; therefore, preliminary examination and assessment is recommended.

METHODS OF MOUNTING

SELECTION OF MOUNTING METHODS

The method of mounting rolling bearings strongly affects their accuracy, life, and performance, so their mounting deserves careful attention. Their characteristics should first be thoroughly studied, and then they should be mounted in the proper manner. It is recommended that the handling procedures for bearings be fully investigated by the design engineers and that standards be established with respect to the following items:

- › **Cleaning the bearings and related parts**
- › **Checking the dimensions and finish of related parts**
- › **Mounting**
- › **Inspection after mounting**
- › **Supply of lubricants**

Bearings should not be unpacked until immediately before mounting. When using ordinary grease lubrication, the grease should be packed in the bearings without first cleaning them.

Even in the case of ordinary oil lubrication, cleaning the bearings is not required. However, bearings for instruments or for high speed operation must first be cleaned with clean filtered oil in order to remove the anti-corrosion agent. After the bearings are cleaned with filtered oil, they should be protected to prevent corrosion. Do not clean prelubricated bearings.

Bearing mounting methods depend on the bearing type and type of fit. As bearings are usually used on rotating shafts, the inner rings require a tight fit. Bearings with cylindrical bores are usually mounted by pressing them onto the shafts (press fit) or heating them to expand their diameter (shrink fit). Bearings with tapered bores can be mounted directly on tapered shafts or cylindrical shafts using tapered sleeves.

Table 1 - Methods of Bearing Mounting

BEARING INNER RING SHAPE	SHAFT SHAPE AND FEATURES		MOUNTING PARTS AND FEATURES		WORKING METHOD
	Shape	Features	Parts	Features	
cylindrical bore	cylindrical	<ul style="list-style-type: none"> › shaft with shoulder › with or without oil duct 	<ul style="list-style-type: none"> › with or without spacer 	--	<ul style="list-style-type: none"> › dead-blow mallet › press › oil heating tank › induction heater
tapered bore	tapered	<ul style="list-style-type: none"> › shaft with shoulder › with or without oil duct 	<ul style="list-style-type: none"> › with or without spacer 	--	<ul style="list-style-type: none"> › lock nut › hydraulic nut
tapered bore	cylindrical	<ul style="list-style-type: none"> › shaft with shoulder 	<ul style="list-style-type: none"> › adapter sleeve › with or without spacer 	<ul style="list-style-type: none"> › with or without oil duct 	<ul style="list-style-type: none"> › lock nut › hydraulic nut › oil injection pump
tapered bore	cylindrical	<ul style="list-style-type: none"> › shaft with shoulder 	<ul style="list-style-type: none"> › withdrawal sleeve 	<ul style="list-style-type: none"> › with or without oil duct 	<ul style="list-style-type: none"> › lock nut › hydraulic nut › oil injection pump

MOUNTING BEARINGS WITH CYLINDRICAL BORES

Press Fits

Fitting with a press requires large force and is therefore widely used for small to medium sized bearings. A mounting tool is placed on the inner ring as shown in **Figure 1.1** and the bearing is slowly pressed onto the shaft with a press until the side of the inner ring rests against the shoulder of the shaft. The mounting tool must not be placed on the outer ring for press mounting, as it may cause the rolling elements to create brinelling indentations on the raceway surfaces as a result of the force applied to the outer ring.

The mounting method using a dead-blow mallet should only be used for small ball bearings with minimally tight fits when a press is not available or cannot be accommodated. In the case of tight interference fits or for medium and large bearings, this method should not be used. Any time a hammer is used, a mounting tool must be placed on the inner ring.

When both the inner and outer rings of non-separable bearings require a tight fit, a mounting tool is placed on both rings as shown in **Figure 1.2**, and both rings are fitted at the same time using a screw or hydraulic press. Since the outer ring of self-aligning ball bearings may misalign, a mounting tool such as that shown in **Figure 1.2** should always be used.

In the case of separable bearings, the inner and outer rings may be mounted separately. In this case, assembly of the inner and outer rings should be done carefully to align the inner and outer rings correctly. Careless or forced assembly may cause scratches on the rolling contact surfaces.

A light oil can be applied to the bearing seat in the case of a tight fit. Anti-fretting paste can be applied to the bearing seat in the case of a loose fit. Do not use molybdenum disulfide (MoS₂) paste on any surface.

A light oil added onto the bore and shaft is sufficient. MoS₂ paste may introduce lube compatibility or other issues such as potential slipping on the journal.



Fig. 1 - Press Fitting of Inner / Inner and Outer Rings

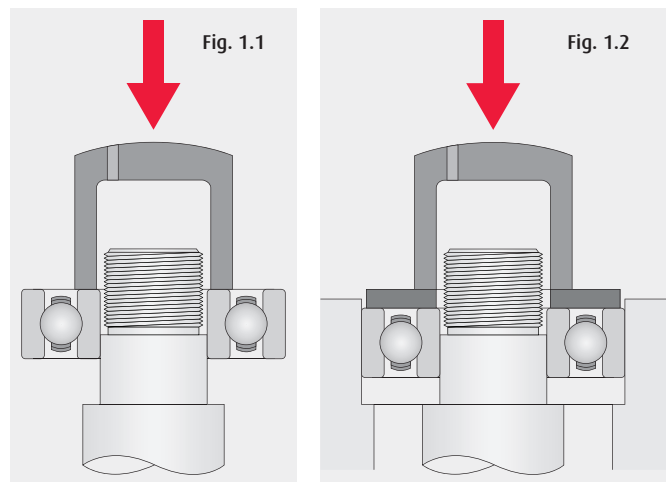

METHODS OF MOUNTING

Shrink Fits

Since press fitting large bearings requires a large force, a shrink fit is widely used. This method prevents an excessive force being imposed on the bearings and allows for relatively quick mounting. Primary methods employed are heating via an oil bath or with an induction heater.

For the oil bath method, the bearings are first heated in a high-quality mineral oil (**Figure 2**) to expand them before mounting. The oil bath should be large enough to accommodate two to five bearings, with a sufficient amount of oil to completely cover the bearings.

Precautions to follow when making shrink fits include:

- › Do not heat bearings to more than 120°C
- › Suspend bearings, or place them on a wire net at the bottom of an oil tank

- › Heat the bearings to a temperature 20 to 30°C higher than the lowest temperature required for mounting without interference to compensate for cooling during mounting
- › After mounting, the bearings will shrink axially and radially; press the bearing firmly against the shaft shoulder using locating methods to avoid a clearance between the bearing and shoulder.

The expansion of inner rings for various temperature differences and bearing sizes is illustrated in **Figure 3**.

After mounting a bearing in place, cool it and apply lubricant to its inner and outer surfaces. At that point, make sure the bearing is free of any dirt. Except when preload is applied to a bearing, a clearance is usually needed for the bearing after mounting; therefore, confirm that the bearing rotates smoothly. For roller bearings, clearance can be measured using a feeler gauge.

Fig. 2 - Oil Bath Heating Method

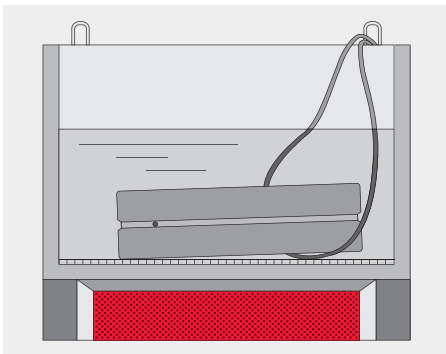

Fig. 3 - Temperature and Thermal Expansion of Inner Ring

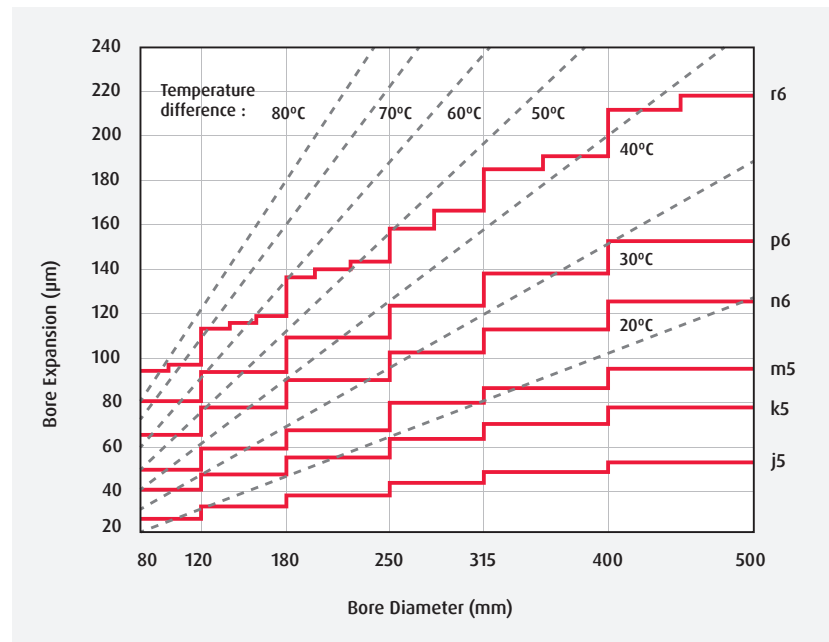
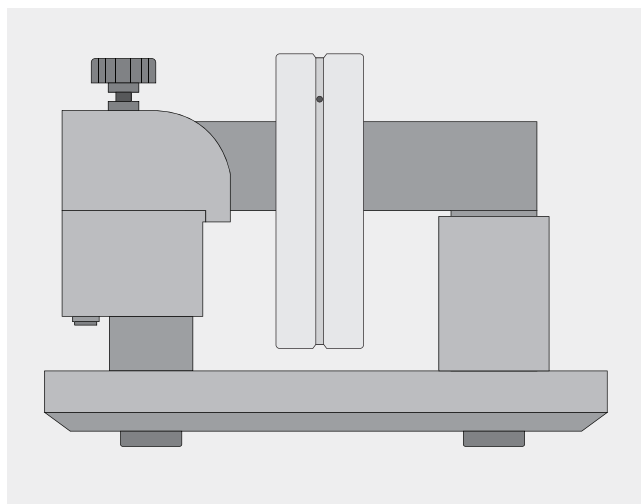

Fig. 4 - Induction Heater Method



An alternative to heating bearings in oil is the use of bearing heaters and electromagnetic induction (**Figure 4**). With induction heating, electricity in a coil produces a magnetic field that induces a current inside the bearing, generating heat. Uniform heating of the bearing is possible, making shrink fitting efficient and clean. Many induction heaters include an automatic demagnetization cycle. Always demagnetize bearings to ensure that they do not attract metallic particles.

A bearing mounted on a shaft cools rapidly, and after heating, an expanded bearing shrinks in a crosswise direction. In some cases, therefore, in order to avoid a clearance between the inner ring and shoulder, press the bearings firmly against the shoulder by means of a shaft nut or other appropriate tool. After mounting a bearing in place, cool it and apply lubricant to its inner and outer surfaces. At that point, make sure the bearing is free of any dirt. Except when preload is applied to a bearing, a clearance is usually needed for the bearing after mounting; therefore, confirm that the bearing rotates smoothly. For roller bearings, clearance can be measured using a feeler gauge.

MOUNTING BEARINGS WITH TAPERED BORES

Bearings with tapered bores are mounted in place using adapter or withdrawal sleeves or mounted directly onto tapered shafts. The degree of fit is determined by reduction in clearance and push-in amount of the sleeves (or bearings). For spherical roller bearings, a decrease in clearance during mounting is usually measured by a feeler gauge.

Spherical roller bearings with tapered bores have generally been manufactured considering the reduction in clearance. Traditionally the method of radial internal clearance reduction is used, but in some cases the push-in amount (axial movement) of the inner ring or withdrawal sleeve is measured instead of directly measuring the reduction in clearance. The angular drive-up by lock nut method is another method used for a select series of spherical roller bearings.

When a feeler gauge cannot be used for small roller bearings because of the small clearance after mounting them in position, the amount of axial movement must be measured instead of the reduction in clearance. Also, in cases where a large bearing is heated in oil to expand it for facilitating mounting, axial movement must also be measured. In this case, the bearing should be initially mounted on the shaft before it is heated, and this initial position measured, then the final mounting position can be determined by the amount of axial movement from the initial mounting position after the bearing has been heated. At this stage, the intended reduction in clearance must be confirmed by measuring the initial clearance prior to heating and the final clearance after cooling.

Supporting information and data for radial clearance reduction, axial drive-up and angular drive-up methods can be found on **pages B11-18**. Step by step mounting instructions utilizing the various methods for bearing and shaft types described in **Table 1**, as well as handling sleeves, lock nuts and hydraulic nuts follow.

MOUNTING BEARINGS WITH TAPERED BORES

MEASURING BEARING CLEARANCE

The internal clearance in rolling bearings during operation influences bearing performance, including fatigue life, rigidity, vibration, noise, and heat generation. Consequently, measuring the internal bearing clearance during mounting is critical to ensure designed bearing performance is achieved. When measuring the internal bearing clearance, pay careful attention to locate the rollers in the appropriate position(s) for the various methods.

MEASURING UNMOUNTED BEARING CLEARANCE

When measuring unmounted internal bearing clearance, stand the bearing upright (vertically) on a flat surface. Rotate the inner ring clockwise and counterclockwise at least one half rotation while keeping both rings and roller sets aligned to each other. Adjust the rollers until one roller on both sides is located at the top (12 o'clock) position. Measure the clearance at the appropriate position(s) with a feeler gauge.



Bearing Outside Diameter Is Smaller Than 200 mm

Measure a single clearance value across both sets of rollers of the bearing (Δr_T , **Figure 5**). Insert the feeler gauge blade to the side of the rollers positioned at the top of the bearing. Select a blade thinner than the minimum value of internal clearance (as listed on **Table 2, page B12**). Slide the blade between the rollers and the outer ring raceway until there is slight resistance. Do not force a blade between the rollers and raceway if the blade pinches. Repeat this process with a thicker blade each time until the blade does not pass between the rollers and the outer ring raceway. Repeat the procedure again at a different outer ring raceway location and different rollers.

Bearing Outside Diameter Is Larger Than 200 mm

For most cases, the clearance measurement method used for unmounted bearings with outside diameter less than 200 mm is adequate. However, the outer ring of large bearings may deform slightly into an elliptical shape due to its own weight. For the purpose of obtaining the true geometrical internal clearance it is recommended to measure multiple clearance values from both rows of the bearing at 3 positions: the top (12 o'clock), the right (3 o'clock), and the left (9 o'clock) (**Figure 6**).

As previously described, use the feeler gauge to measure the clearance values at the top of the bearing (Δr_T) from each row of the bearing. The internal clearance for this position is:

$$\Delta r_T = 1/2 (\Delta r_{T1} + \Delta r_{T2})$$

Repeat the clearance measurements for the right and left positions. The respective internal clearances are as follows:

$$\Delta r_L = 1/2 (\Delta r_{L1} + \Delta r_{L2})$$

$$\Delta r_R = 1/2 (\Delta r_{R1} + \Delta r_{R2})$$

The internal clearance for the bearing is calculated as follows:

$$\Delta r = 1/2 (\Delta r_T + \Delta r_L + \Delta r_R)$$

Fig. 5 - Measuring Clearance (O.D < 200 mm)

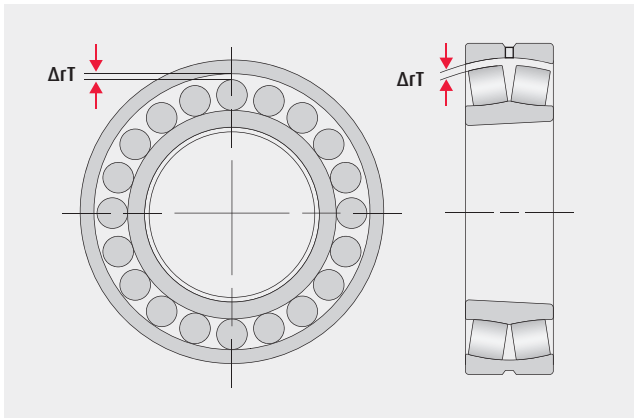

Fig. 6 - Measuring Clearance (O.D > 200 mm)

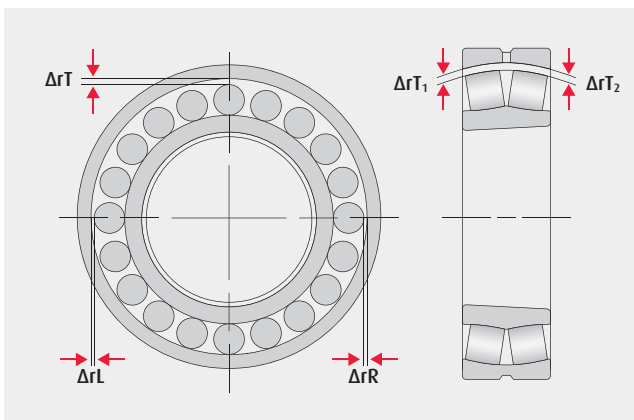
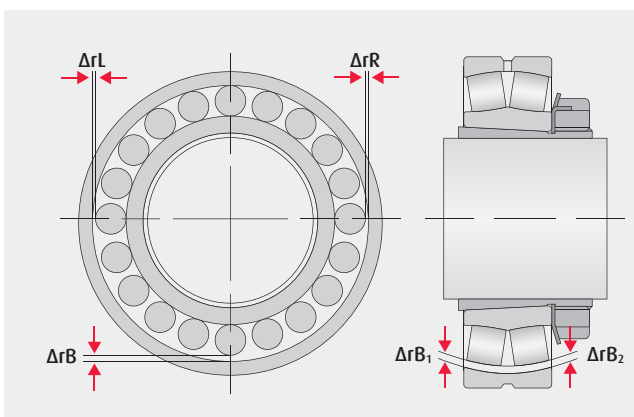

Fig. 7 - Measuring Mounted Clearance (O.D > 200 mm)



MEASURING MOUNTED BEARING CLEARANCE

When measuring mounted internal bearing clearance it is recommended to follow the same methodology employed prior to the bearing mounting for comparative purposes. In this case the mounted bearing is seated and suspended on a shaft in an upright (vertical) orientation. Rotate the inner ring clockwise and counterclockwise at least one half rotation while keeping both rings and roller sets aligned to each other. Adjust the rollers until one roller on both sides is located at the bottom (6 o'clock) position. Measure the clearance at the appropriate position(s) with a feeler gauge.

Bearing Outside Diameter Is Smaller Than 200 mm

Follow the procedure described / employed for measuring unmounted bearings, but in this case measuring clearance from the side of the roller(s) positioned at the bottom of the bearing to measure the clearance ΔrB (6 o'clock).

Bearing Outside Diameter Is Larger Than 200 mm

Follow the procedure described / employed for measuring unmounted bearings, but in this case measuring clearance from the side of the roller(s) positioned at the bottom of the bearing to measure the clearance ΔrB (6 o'clock). If measuring true geometrical internal clearance, measure the clearance at the bottom, ΔrB (6 o'clock), the right, ΔrR (3 o'clock), and the left, ΔrL (9 o'clock) (**Figure 7**).

Follow the calculations provided on **page B9**, substituting clearance values for ΔrT with ΔrB .

Note: In cases where the mounted bearing is resting on a bench or seated in a housing, the clearance measurement should be taken from the 12 o'clock position (**Figure 6**) rather than the bottom position as described above.

MOUNTING BEARINGS WITH TAPERED BORES

RADIAL CLEARANCE REDUCTION METHOD

PROCEDURE - ADAPTER SLEEVES

Spherical roller bearings with tapered bores must be mounted to a tapered shaft, adapter sleeve, or withdrawal sleeve. When pushing the bearing onto the tapered shaft or sleeve, the inner ring of the bearing expands, resulting in an increase of interference fit to the shaft and a **Reduction in Radial Internal Clearance**. Obtaining proper interference and internal clearance is important when mounting the bearing.

The bearing should be driven up the tapered shaft or sleeve in small increments. The radial internal clearance should be measured after each incremental adjustment to ensure that the bearing isn't driven up too far onto the taper. Repeat the procedure of driving up the bearing in small increments until the desired radial internal clearance reduction is obtained.

See **Table 2**.

Note: Always use clearance tables provided by the manufacturer of the bearing installed. Using alternative tables can result in clearances that are too tight or loose, and lead to bearing damage, including inner ring fracture. Always verify the final radial internal clearance with a feeler gauge.

If heat is used to install the bearing - make sure the bearing and mating components (shaft, etc.) have all cooled to the same temperature before measuring

If a lock washer is used to lock the nut - prior to bending the lock washer tab into the slot of the nut, verify once again that the clearance matches specification and has not changed during installation of the lock washer.

If a hydraulic nut is used to install the bearing - verify the radial internal clearance before locking the lock nut.

If an oil injection pump is used to assist in installation - the oil pressure must be bled to zero before verifying the final measurement with the feeler gauge. Measuring with oil injection pressure still applied can make the measurement appear smaller than the actual clearance of the bearing

CLEARANCE REDUCTION AMOUNT

When radial internal clearance is CN (normal clearance), C3 or C4, target the clearance adjustment at the lower end of the reduction range unless the bearing is subject to high vibration, heavy loads or is manufactured with case hardened inner rings, in which case the upper end of the reduction range is recommended.

When the load condition is known, target the following clearance reduction amounts:

- › For light or normal loads, use the lower half of the reduction range
- › For heavy or shock loads, use the upper half of the reduction range

INTERNAL CLEARANCE ADJUSTMENT

Perform the adjustment by measuring the clearance reduction amount with the feeler gauge.

- › For measurement position and measured point, refer to **Measuring Bearing Clearance on pages B9 and 10**.
- › When mounting a bearing on a tapered shaft, repeat the clearance measurement each time the bearing is driven up by the lock nut, end plate, end cap or hydraulic nut.
- › When using an adapter sleeve, repeat the clearance measurement each time the bearing is driven up by the lock nut or hydraulic nut.
- › When using a withdrawal sleeve, measure clearance each time the withdrawal sleeve is driven up by the lock nut or hydraulic nut.

Record the value of each clearance measurement for use in the clearance adjustment process.

Table 2 - Radial Clearance Reduction for Spherical Roller Bearings with Tapered Bore

NOMINAL BORE DIAMETER (MM)		RADIAL INTERNAL CLEARANCE (INCH)						REDUCTION IN RADIAL CLEARANCE (INCH)		AXIAL DISPLACEMENT* (INCH)				MINIMUM PERMISSIBLE RESIDUAL CLEARANCE AFTER MOUNTING (INCH)		
		CN		C3		C4				Taper 1:12		Taper 1:30				
over	incl.	min	max	min	max	min	max	min	max	min	max	min	max	CN	C3	C4
30	40	0.0014	0.0020	0.0020	0.0026	0.0026	0.0033	0.0010	0.0012	0.0157	0.0177	-	-	0.0004	0.0010	0.0014
40	50	0.0018	0.0024	0.0024	0.0031	0.0031	0.0039	0.0012	0.0014	0.0177	0.0217	-	-	0.0006	0.0012	0.0018
50	65	0.0022	0.0030	0.0030	0.0037	0.0037	0.0047	0.0012	0.0014	0.0177	0.0217	-	-	0.0010	0.0014	0.0024
65	80	0.0028	0.0037	0.0037	0.0047	0.0047	0.0059	0.0016	0.0018	0.0236	0.0276	-	-	0.0012	0.0016	0.0030
80	100	0.0031	0.0043	0.0043	0.0055	0.0055	0.0071	0.0018	0.0022	0.0276	0.0335	0.0689	0.0846	0.0014	0.0020	0.0033
100	120	0.0039	0.0053	0.0053	0.0067	0.0067	0.0087	0.0020	0.0024	0.0295	0.0354	0.0748	0.0886	0.0018	0.0026	0.0043
120	140	0.0047	0.0063	0.0063	0.0079	0.0079	0.0102	0.0024	0.0028	0.0354	0.0433	0.0886	0.1083	0.0022	0.0031	0.0051
140	160	0.0051	0.0071	0.0071	0.0091	0.0091	0.0118	0.0026	0.0031	0.0394	0.0512	0.0984	0.1280	0.0024	0.0039	0.0059
160	180	0.0055	0.0079	0.0079	0.0102	0.0102	0.0134	0.0028	0.0035	0.0433	0.0551	0.1083	0.1378	0.0028	0.0043	0.0067
180	200	0.0063	0.0087	0.0087	0.0114	0.0114	0.0146	0.0031	0.0039	0.0512	0.0630	0.1280	0.1575	0.0028	0.0043	0.0075
200	225	0.0071	0.0098	0.0098	0.0126	0.0126	0.0161	0.0035	0.0043	0.0551	0.0669	0.1378	0.1673	0.0031	0.0051	0.0083
225	250	0.0079	0.0106	0.0106	0.0138	0.0138	0.0177	0.0039	0.0047	0.0630	0.0748	0.1575	0.1870	0.0035	0.0055	0.0091
250	280	0.0087	0.0118	0.0118	0.0154	0.0154	0.0193	0.0043	0.0055	0.0669	0.0866	0.1673	0.2165	0.0039	0.0059	0.0098
280	315	0.0094	0.0130	0.0130	0.0169	0.0169	0.0213	0.0047	0.0059	0.0748	0.0945	0.1870	0.2362	0.0043	0.0063	0.0110
315	355	0.0106	0.0142	0.0142	0.0185	0.0185	0.0232	0.0055	0.0067	0.0866	0.1063	0.2165	0.2657	0.0047	0.0071	0.0118
355	400	0.0118	0.0157	0.0157	0.0205	0.0205	0.0256	0.0059	0.0075	0.0945	0.1181	0.2362	0.2953	0.0051	0.0079	0.0130
400	450	0.0130	0.0173	0.0173	0.0224	0.0224	0.0283	0.0067	0.0083	0.1063	0.1299	0.2657	0.3248	0.0055	0.0087	0.0142
450	500	0.0146	0.0193	0.0193	0.0248	0.0248	0.0311	0.0075	0.0094	0.1181	0.1457	0.2953	0.3642	0.0063	0.0094	0.0154
500	560	0.0161	0.0213	0.0213	0.0268	0.0268	0.0343	0.0083	0.0106	0.1339	0.1693	0.3346	0.4331	0.0067	0.0106	0.0161
560	630	0.0181	0.0236	0.0236	0.0299	0.0299	0.0386	0.0091	0.0118	0.1457	0.1890	0.3642	0.4724	0.0079	0.0122	0.0181
630	710	0.0201	0.0264	0.0264	0.0335	0.0335	0.0429	0.0102	0.0130	0.1654	0.2087	0.4134	0.5118	0.0087	0.0130	0.0205
710	800	0.0224	0.0295	0.0295	0.0378	0.0378	0.0480	0.0110	0.0146	0.1772	0.2323	0.4528	0.5906	0.0094	0.0154	0.0232
800	900	0.0252	0.0331	0.0331	0.0421	0.0421	0.0539	0.0122	0.0161	0.1969	0.2598	0.4921	0.6496	0.0110	0.0169	0.0260
900	1,000	0.0280	0.0366	0.0366	0.0469	0.0469	0.0598	0.0134	0.0181	0.2165	0.2913	0.5512	0.7283	0.0122	0.0185	0.0287
1,000	1,120	0.0303	0.0406	0.0406	0.0512	0.0512	0.0657	0.0146	0.0197	0.2323	0.3150	0.5906	0.7874	0.0142	0.0209	0.0315

*Axial displacement values apply only to solid steel shafts or hollow steel shafts where the bore is equal to or less than one-half of the outside diameter. If the material is other than steel, or if thin wall journals are used, please consult NSK.

Taper 1:12 applies to series 213, 222, 223, 230, 231, 232, 233, 238 and 239. Taper 1:30 applies to series 240, 241 and 242.

For normal (CN) clearance, target the middle of the reduction range. For C3 or C4 clearance, target the upper half of the reduction range. For light or normal loads, target the lower half of the reduction range. For heavy or shock loads, target the upper half of the reduction range.

MOUNTING BEARINGS WITH TAPERED BORES

AXIAL DRIVE-UP METHOD

AXIAL DRIVE-UP METHOD

This method can be used for medium and large bearings with a tapered bore being mounted with an adapter or withdrawal sleeve, or directly onto a tapered shaft. The hydraulic nut provides the drive-up force to seat the bearing on the journal. This method is most beneficial as the bearings get large and the required force becomes too great for other manual methods. **Tables 3.1 to 3.9** provide the pressure necessary to move the bearing into the starting position along with a measured axial drive-up distance, typically executed with use of a dial indicator.

Figure 8 illustrates axial drive-up starting and final positions (**Figure 8.1**) as well as relative sliding surfaces for mounting directly onto a tapered shaft (**Figure 8.2**), with an adapter sleeve (**Figure 8.3, 8.4**) or withdrawal sleeve (**Figure 8.5**).

Table 3.1 - Series 213
Pressure and Axial Drive-Up for Spherical Roller Bearings

PART NO.	TOTAL REDUCTION IN RADIAL CLEARANCE (INCH)		PRESSURE AND DRIVE-UP		REMAINING DRIVE-UP DISTANCE (INCH)
	min	max	1 Surface (psi)	2 Surfaces (psi)	
21310EAK	0.0012	0.0014	359	652	0.0185
21311EAK	0.0012	0.0014	262	476	0.0168
21312EAK	0.0012	0.0014	366	666	0.0185
21313EAK	0.0012	0.0014	355	645	0.0184
21314EAK	0.0016	0.0018	456	828	0.0238
21315EAK	0.0016	0.0018	369	670	0.0222
21316EAK	0.0016	0.0018	388	705	0.0224
21317EAK	0.0018	0.0022	349	635	0.0245
21318EAK	0.0018	0.0022	350	636	0.0246
21319CAMK	0.0018	0.0022	423	770	0.0258
21320CAMK	0.0018	0.0022	455	826	0.0255
21322CAMK	0.0020	0.0024	458	832	0.0284

Fig. 8 - Axial Drive-Up and Sliding Surfaces

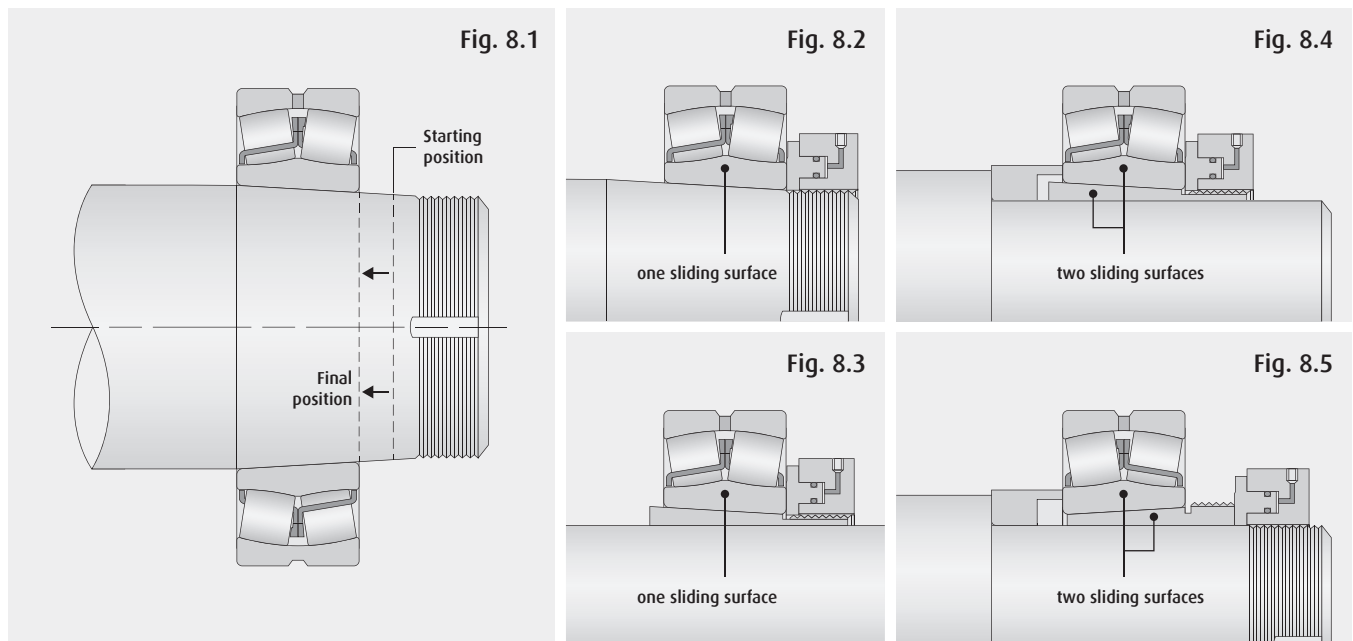

Table 3.2 - Series 222
Pressure and Axial Drive-Up for Spherical Roller Bearings

PART NO.	TOTAL REDUCTION IN RADIAL CLEARANCE (INCH)		PRESSURE AND DRIVE-UP		REMAINING DRIVE-UP DISTANCE
			1 Surface	2 Surfaces	
	min	max	psi	psi	inch
22210EAK	0.0012	0.0014	148	269	0.0153
22211EAK	0.0012	0.0014	145	263	0.0152
22212EAK	0.0012	0.0014	166	302	0.0154
22213EAK	0.0012	0.0014	189	343	0.0157
22214EAK	0.0016	0.0018	197	357	0.0198
22215EAK	0.0016	0.0018	162	294	0.0193
22216EAK	0.0016	0.0018	177	322	0.0195
22217EAK	0.0018	0.0022	223	406	0.0230
22218EAK	0.0018	0.0022	244	443	0.0232
22219EAK	0.0018	0.0022	261	475	0.0233
22220EAK	0.0018	0.0022	252	459	0.0230
22222EAK	0.0020	0.0024	273	495	0.0250
22224EAK	0.0020	0.0024	284	517	0.0251
22226EAK	0.0024	0.0028	333	606	0.0294
22228CAMK	0.0024	0.0028	349	634	0.0296
22230CAMK	0.0026	0.0031	399	726	0.0332
22232CAMK	0.0026	0.0031	375	682	0.0331
22234CAMK	0.0028	0.0035	446	811	0.0371
22236CAMK	0.0028	0.0035	349	635	0.0361
22238CAMK	0.0031	0.0039	391	711	0.0409
22240CAMK	0.0031	0.0039	407	740	0.0413
22244CAMK	0.0035	0.0043	431	783	0.0458
22248CAMK	0.0039	0.0047	468	851	0.0505
22252CAMK	0.0043	0.0055	515	937	0.0575
22256CAMK	0.0043	0.0055	431	784	0.0569
22260CAMK	0.0047	0.0059	471	856	0.0619
22264CAMK	0.0055	0.0067	526	956	0.0712

Table 3.3 - Series 223
Pressure and Axial Drive-Up for Spherical Roller Bearings

PART NO.	TOTAL REDUCTION IN RADIAL CLEARANCE (INCH)		PRESSURE AND DRIVE-UP		REMAINING DRIVE-UP DISTANCE
			1 Surface	2 Surfaces	
	min	max	psi	psi	inch
22310EAK	0.0012	0.0014	382	695	0.0167
22311EAK	0.0012	0.0014	409	744	0.0170
22312EAK	0.0012	0.0014	406	738	0.0168
22313EAK	0.0012	0.0014	371	674	0.0166
22314EAK	0.0016	0.0018	489	889	0.0217
22315EAK	0.0016	0.0018	494	898	0.0215
22316EAK	0.0016	0.0018	488	888	0.0214
22317EAK	0.0018	0.0022	573	1042	0.0252
22318EAK	0.0018	0.0022	555	1009	0.0250
22319EAK	0.0018	0.0022	544	989	0.0248
22320EAK	0.0018	0.0022	610	1110	0.0252
22322EAK	0.0020	0.0024	711	1293	0.0282
22324EAK	0.0020	0.0024	692	1258	0.0279
22326CAMK	0.0024	0.0028	757	1376	0.0321
22328CAMK	0.0024	0.0028	765	1391	0.0319
22330CAMK	0.0026	0.0031	828	1505	0.0357
22332CAMK	0.0026	0.0031	754	1371	0.0356
22334CAMK	0.0028	0.0035	666	1211	0.0376
22336CAMK	0.0028	0.0035	641	1166	0.0376
22338CAMK	0.0031	0.0039	678	1232	0.0423
22340CAMK	0.0031	0.0039	796	1447	0.0443
22344CAMK	0.0035	0.0043	737	1340	0.0481
22348CAMK	0.0039	0.0047	758	1378	0.0529
22352CAMK	0.0043	0.0055	802	1458	0.0600
22356CAMK	0.0043	0.0055	756	1375	0.0600
22360CAMK	0.0047	0.0059	765	1391	0.0646
22364CAMK	0.0055	0.0067	891	1620	0.0749

*Values apply only to solid steel shafts or hollow steel shafts where the shaft bore is equal to or less than one-half of the shaft outside diameter. If the material is other than steel, or if thin wall journals are used, please consult NSK.

MOUNTING BEARINGS WITH TAPERED BORES

AXIAL DRIVE-UP METHOD

Table 3.4 - Series 230
Pressure and Axial Drive-Up for Spherical Roller Bearings

PART NO.	TOTAL REDUCTION IN RADIAL CLEARANCE (INCH)		PRESSURE AND DRIVE-UP		REMAINING DRIVE-UP DISTANCE
			1 Surface	2 Surfaces	
	min	max	psi	psi	inch
23020CDK	0.0018	0.0022	129	235	0.0216
23022CDK	0.002	0.0024	169	308	0.0239
23024CDK	0.002	0.0024	149	271	0.0237
23026CDK	0.0024	0.0028	201	365	0.0282
23028CDK	0.0024	0.0028	179	326	0.0279
23030CDK	0.0026	0.0031	198	359	0.0312
23032CDK	0.0026	0.0031	179	326	0.0311
23034CDK	0.0028	0.0035	213	387	0.0345
23036CDK	0.0028	0.0035	207	377	0.0343
23038CAMK	0.0031	0.0039	216	393	0.0387
23040CAMK	0.0031	0.0039	249	453	0.0393
23044CAMK	0.0035	0.0043	238	433	0.0431
23048CAMK	0.0039	0.0047	206	375	0.0467
23052CAMK	0.0043	0.0055	238	433	0.0531
23056CAMK	0.0043	0.0055	219	398	0.0532
23060CAMK	0.0047	0.0059	264	481	0.0582
23064CAMK	0.0055	0.0067	256	465	0.0661
23068CAMK	0.0055	0.0067	270	491	0.0664
23072CAMK	0.0059	0.0075	250	454	0.0721
23076CAMK	0.0059	0.0075	230	419	0.0719
23080CAMK	0.0059	0.0075	233	424	0.072
23084CAMK	0.0067	0.0083	238	433	0.0803
23088CAMK	0.0067	0.0083	231	420	0.0801
23092CAMK	0.0075	0.0094	260	473	0.0908
23096CAMK	0.0075	0.0094	225	410	0.0901

Table 3.5 - Series 231
Pressure and Axial Drive-Up for Spherical Roller Bearings

PART NO.	TOTAL REDUCTION IN RADIAL CLEARANCE (INCH)		PRESSURE AND DRIVE-UP		REMAINING DRIVE-UP DISTANCE
			1 Surface	2 Surfaces	
	min	max	psi	psi	inch
23120CK	0.0018	0.0022	213	387	0.022
23122CK	0.002	0.0024	261	474	0.0246
23124CK	0.002	0.0024	255	463	0.0244
23126CK	0.0024	0.0028	283	514	0.0286
23128CK	0.0024	0.0028	258	470	0.0283
23130CK	0.0026	0.0031	369	671	0.0323
23132CK	0.0026	0.0031	344	626	0.0323
23134CK	0.0028	0.0035	323	588	0.0351
23136CK	0.0028	0.0035	329	599	0.0352
23138CK	0.0031	0.0039	378	688	0.0399
23140CK	0.0031	0.0039	392	712	0.0401
23144CK	0.0035	0.0043	385	700	0.0442
23148CK	0.0039	0.0047	376	684	0.0482
23152CAMK	0.0043	0.0055	432	785	0.055
23156CAMK	0.0043	0.0055	366	666	0.0545
23160CAMK	0.0047	0.0059	402	730	0.0591
23164CAMK	0.0055	0.0067	466	847	0.068
23168CAMK	0.0055	0.0067	496	901	0.0686
23172CAMK	0.0059	0.0075	456	829	0.0743
23176CAMK	0.0059	0.0075	409	745	0.0738
23180CAMK	0.0059	0.0075	391	711	0.0739
23184CAMK	0.0067	0.0083	467	849	0.083
23188CAMK	0.0067	0.0083	423	769	0.0824
23192CAMK	0.0075	0.0094	491	892	0.0936
23196CAMK	0.0075	0.0094	466	847	0.0934

*Values apply only to solid steel shafts or hollow steel shafts where the shaft bore is equal to or less than one-half of the shaft outside diameter. If the material is other than steel, or if thin wall journals are used, please consult NSK.

Table 3.6 - Series 232
Pressure and Axial Drive-Up for Spherical Roller Bearings

PART NO.	TOTAL REDUCTION IN RADIAL CLEARANCE (INCH)		PRESSURE AND DRIVE-UP		REMAINING DRIVE-UP DISTANCE
			1 Surface	2 Surfaces	
	min	max	psi	psi	inch
23218CK	0.0018	0.0022	287	521	0.0227
23219CK	0.0018	0.0022	290	527	0.0227
23220CK	0.0018	0.0022	327	595	0.023
23222CK	0.002	0.0024	378	687	0.0252
23224CK	0.002	0.0024	361	656	0.0249
23226CK	0.0024	0.0028	400	727	0.0292
23228CK	0.0024	0.0028	437	795	0.0294
23230CK	0.0026	0.0031	505	919	0.033
23232CK	0.0026	0.0031	484	880	0.0331
23234CK	0.0028	0.0035	524	953	0.0366
23236CK	0.0028	0.0035	462	839	0.0362
23238CK	0.0031	0.0039	486	883	0.0405
23240CK	0.0031	0.0039	519	944	0.0411
23244CK	0.0035	0.0043	556	1011	0.0455
23248CAMK	0.0039	0.0047	579	1053	0.0498
23252CAMK	0.0043	0.0055	648	1178	0.0569
23256CAMK	0.0043	0.0055	539	981	0.0561
23260CAMK	0.0047	0.0059	577	1050	0.0607
23264CAMK	0.0055	0.0067	667	1213	0.0701
23268CAMK	0.0055	0.0067	672	1222	0.0702
23272CAMK	0.0059	0.0075	659	1199	0.0763
23276CAMK	0.0059	0.0075	636	1155	0.0763
23280CAMK	0.0059	0.0075	616	1119	0.0762
23284CAMK	0.0067	0.0083	689	1252	0.0855
23288CAMK	0.0067	0.0083	655	1190	0.0852
23292CAMK	0.0075	0.0094	782	1423	0.0974
23296CAMK	0.0075	0.0094	722	1313	0.0965

Table 3.7 - Series 239
Pressure and Axial Drive-Up for Spherical Roller Bearings

PART NO.	TOTAL REDUCTION IN RADIAL CLEARANCE (INCH)		PRESSURE AND DRIVE-UP		REMAINING DRIVE-UP DISTANCE
			1 Surface	2 Surfaces	
	min	max	psi	psi	inch
23926CAMK	0.0024	0.0028	98	177	0.0271
23932CAMK	0.0026	0.0031	98	177	0.0301
23934CAMK	0.0028	0.0035	93	170	0.0331
23936CAMK	0.0028	0.0035	109	197	0.0333
23938CAMK	0.0031	0.0039	104	189	0.0373
23940CAMK	0.0031	0.0039	125	227	0.0377
23944CAMK	0.0035	0.0043	106	192	0.0414
23948CAMK	0.0039	0.0047	94	170	0.0452
23952CAMK	0.0043	0.0055	140	254	0.0521
23956CAMK	0.0043	0.0055	117	212	0.0517
23960CAMK	0.0047	0.0059	149	271	0.0563
23964CAMK	0.0055	0.0067	150	272	0.0645
23968CAMK	0.0055	0.0067	123	224	0.0638
23972CAMK	0.0059	0.0075	121	219	0.0699
23976CAMK	0.0059	0.0075	148	270	0.0705
23980CAMK	0.0059	0.0075	126	229	0.0701
23984CAMK	0.0067	0.0083	124	225	0.078
23988CAMK	0.0067	0.0083	138	251	0.0784
23992CAMK	0.0075	0.0094	141	257	0.0884
23996CAMK	0.0075	0.0094	144	261	0.0885

*Values apply only to solid steel shafts or hollow steel shafts where the shaft bore is equal to or less than one-half of the shaft outside diameter. If the material is other than steel, or if thin wall journals are used, please consult NSK.

MOUNTING BEARINGS WITH TAPERED BORES

AXIAL DRIVE-UP METHOD

Table 3.8 - Series 240
Pressure and Axial Drive-Up for Spherical Roller Bearings

PART NO.	TOTAL REDUCTION IN RADIAL CLEARANCE (INCH)		PRESSURE AND DRIVE-UP		REMAINING DRIVE-UP DISTANCE
			1 Surface	2 Surfaces	
	min	max	psi	psi	inch
24020CK30	0.0018	0.0022	172	313	0.0539
24022CK30	0.002	0.0024	222	403	0.0597
24024CK30	0.002	0.0024	188	342	0.0589
24026CK30	0.0024	0.0028	263	478	0.0703
24028CK30	0.0024	0.0028	233	423	0.0697
24030CK30	0.0026	0.0031	261	474	0.0779
24032CK30	0.0026	0.0031	248	451	0.078
24034CK30	0.0028	0.0035	294	534	0.0864
24036CK30	0.0028	0.0035	309	562	0.0868
24038CK30	0.0031	0.0039	297	540	0.097
24040CK30	0.0031	0.0039	318	579	0.0978
24044CK30	0.0035	0.0043	321	584	0.108
24048CK30	0.0039	0.0047	287	521	0.1177
24052CAMK30	0.0043	0.0055	345	627	0.134
24056CAMK30	0.0043	0.0055	297	540	0.1333
24060CAMK30	0.0047	0.0059	343	624	0.1447
24064CAMK30	0.0055	0.0067	336	611	0.1651
24068CAMK30	0.0055	0.0067	382	694	0.1668
24072CAMK30	0.0059	0.0075	357	649	0.1815
24076CAMK30	0.0059	0.0075	311	565	0.18
24080CAMK30	0.0059	0.0075	322	586	0.1804
24084CAMK30	0.0067	0.0083	329	598	0.2015
24088CAMK30	0.0067	0.0083	333	606	0.2018
24092CAMK30	0.0075	0.0094	369	671	0.2285
24096CAMK30	0.0075	0.0094	319	581	0.2268

Table 3.9 - Series 241
Pressure and Axial Drive-Up for Spherical Roller Bearings

PART NO.	TOTAL REDUCTION IN RADIAL CLEARANCE (INCH)		PRESSURE AND DRIVE-UP		REMAINING DRIVE-UP DISTANCE
			1 Surface	2 Surfaces	
	min	max	psi	psi	inch
24122CK30	0.002	0.0024	300	545	0.0609
24124CK30	0.002	0.0024	357	649	0.0617
24126CK30	0.0024	0.0028	370	674	0.0721
24128CK30	0.0024	0.0028	341	620	0.0712
24130CK30	0.0026	0.0031	457	830	0.0807
24132CK30	0.0026	0.0031	429	781	0.0805
24134CK30	0.0028	0.0035	414	752	0.0882
24136CK30	0.0028	0.0035	422	768	0.0885
24138CK30	0.0031	0.0039	442	804	0.0989
24140CK30	0.0031	0.0039	491	892	0.1003
24144CK30	0.0035	0.0043	502	913	0.1112
24148CK30	0.0039	0.0047	471	855	0.1206
24152CK30	0.0043	0.0055	591	1075	0.1393
24156CAMK30	0.0043	0.0055	485	882	0.1375
24160CAMK30	0.0047	0.0059	531	965	0.1489
24164CAMK30	0.0055	0.0067	628	1143	0.1722
24168CAMK30	0.0055	0.0067	649	1180	0.1722
24172CAMK30	0.0059	0.0075	606	1102	0.187
24176CAMK30	0.0059	0.0075	541	984	0.1857
24180CAMK30	0.0059	0.0075	503	915	0.1854
24184CAMK30	0.0067	0.0083	656	1193	0.2111
24188CAMK30	0.0067	0.0083	588	1069	0.2095
24192CAMK30	0.0075	0.0094	654	1190	0.2361
24196CAMK30	0.0075	0.0094	617	1122	0.2357

*Values apply only to solid steel shafts or hollow steel shafts where the shaft bore is equal to or less than one-half of the shaft outside diameter. If the material is other than steel, or if thin wall journals are used, please consult NSK.

MOUNTING BEARINGS WITH TAPERED BORES

ANGULAR DRIVE-UP METHOD



ANGULAR DRIVE-UP METHOD

This method can be used for series 222 and 223 spherical roller bearings and for self-aligning ball bearings and relies on tightening the lock nut to a predetermined angle specific to the bearing part number. After hand-tightening the lock nut to a position where the adapter sleeve no longer rotates or moves axially on the shaft, a reference point made at the 12 o'clock position on the lock nut face serves as the starting point to complete the bearing drive-up to the specified tightening angle with a spanner wrench and hammer. **Table 4** provides the angular turn guidelines for series 222 and 223 spherical roller bearings. For self-aligning ball bearings, see **Tables 5 and 6** on pages B41 and 42.

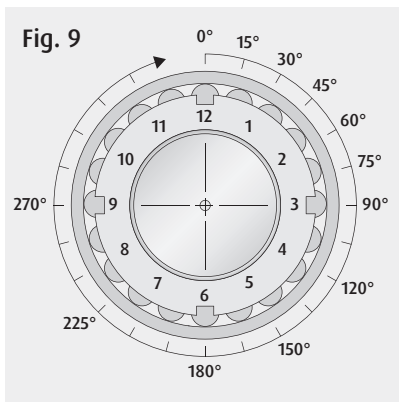

Figure 9 depicts angular turns, such as the data presented in **Table 4**, relative to a 12 o'clock reference point.

Table 4 - Series 222 and 223
Angular Drive-up for Spherical Roller Bearings, Inch and Metric Lock Nut

BORE DIAMETER (MM)	AXIAL DRIVE UP (IN)		INCH LOCK NUT	ANGULAR TURN (DEGREES)		METRIC LOCK NUT	ANGULAR TURN (DEGREES)	
	min	max		min	max		min	max
35	0.016	0.018	N07	100	115	KM7	95	105
40	0.016	0.018	N08	100	115	KM8	95	105
45	0.018	0.022	N09	115	140	KM9	105	130
50	0.018	0.022	N10	115	140	KM10	105	130
55	0.018	0.022	N11	115	140	KM11	80	100
60	0.018	0.022	N12	115	140	KM12	80	100
65	0.018	0.022	N13	115	140	KM13	80	100
70	0.024	0.028	N14	155	180	KM14	105	125
75	0.024	0.028	AN15	100	120	KM15	105	125
80	0.024	0.028	AN16	100	120	KM16	105	125
85	0.028	0.034	AN17	120	145	KM17	125	155
90	0.028	0.034	AN18	120	145	KM18	125	155
95	0.028	0.034	AN19	120	145	KM19	125	155
100	0.028	0.034	AN20	120	145	KM20	125	155
105	0.030	0.035	AN21	125	150	KM21	135	160
110	0.030	0.035	AN22	125	150	KM22	135	160
120	0.030	0.035	AN24	125	150	KM24	135	160
130	0.035	0.043	AN26	150	185	KM26	160	195
140	0.035	0.043	AN28	150	185	KM28	160	195
150	0.039	0.051	AN30	165	220	KM30	175	230
160	0.039	0.051	AN32	110	145	KM32	115	155
170	0.043	0.055	AN34	120	155	KM34	130	165
180	0.043	0.055	AN36	120	155	KM36	130	165
190	0.051	0.063	AN38	145	180	KM38	155	190
200	0.051	0.063	AN40	145	180	KM40	155	190

*Values apply only to solid steel shafts or hollow steel shafts where the shaft bore is equal to or less than one-half of the shaft outside diameter. If the material is other than steel, or if thin wall journals are used, please consult NSK.

MOUNTING BEARINGS WITH TAPERED BORES

HANDLING OF SLEEVES AND LOCK NUTS

PROCEDURE - ADAPTER SLEEVES

1. Unpack the adapter while wearing clean thin rubber gloves. Put it upright on the surface plate and remove the lock nut mounted on the adapter.
2. Wipe the surface of the shaft with clean oil to remove dirt, then wipe the shaft and the adapter bore with a clean cloth to remove oils from these surfaces. Also wipe clean the tapers of the adapter OD and bearing bore to remove oils.
3. Verify that the shaft diameter is within specification.
4. Before mounting, apply a light oil to all mating surfaces.
5. Mount the adapter sleeve so that its threaded end is toward the shaft end. For shafts with shoulders (**Figure 10**), if a spacer ring is needed, insert the adapter sleeve into the bore of the spacer ring face, then mount onto the shaft. For straight shafts without shoulders, mount the adapter ring into the desired axial position on the shaft, keeping in mind that the bearing will move up the taper as the lock nut is tightened. To facilitate mounting the adapter sleeve onto the shaft, the slot can be widened slightly by holding it open with a screwdriver or chisel.



6. Measure and record the bearing internal clearance. This is the Measured Initial Clearance.
7. With bearing and sleeve tapered surfaces aligned, mount the bearing onto the adapter sleeve. For a shaft with shoulder and spacer ring, the bearing inner ring end face should contact the spacer ring end face.

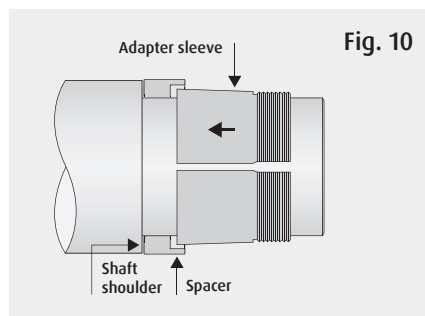

PROCEDURE - WITHDRAWAL SLEEVES

Begin by executing Steps 1 to 4 of **Procedure - Adapter Sleeves**, then continue with the following steps:

5. If a spacer ring is needed, then mount it onto the shaft.
6. Measure and record the bearing internal clearance. This is the Measured Initial Clearance.
7. Install the bearing onto the shaft with the larger side of the tapered bore oriented toward the shaft end. If a spacer ring is used, the bearing inner ring end face should contact the spacer ring end face (**Figure 11**).
8. After mounting the bearing, mount the withdrawal sleeve on the shaft with the threaded portion of the sleeve oriented toward the shaft end. Slide the withdrawal sleeve into the bearing bore as it is installed. To facilitate mounting the withdrawal sleeve onto the shaft, the slot can be widened slightly by holding it open with a screwdriver or chisel.

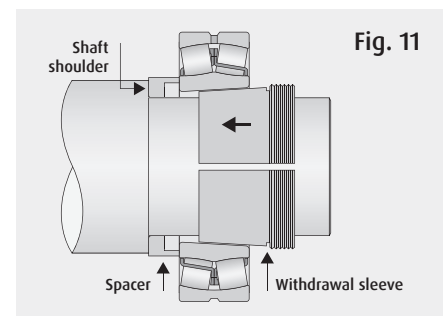

METHODS TO SECURE LOCK NUT

The lock nut should be secured from loosening during operation using a lock washer or a lock plate. The final position of a lock plate is set during radial clearance setting. A lock washer is not used during clearance setting, so lock washer thickness must be accounted for in setting its final position. The final position is verified using matching marks, vernier caliper or direct check methods.

Matching marks method (Fig. 12)

Before the lock nut is loosened, matching marks are applied to the lock nut and adapter sleeve/shaft end after completing the clearance setting (Figure 12.1). The final lock nut position is determined by a change in angle based on the thickness of the lock washer and the pitch of the lock nut (Figure 12.2). If the change in angle is more than 360 degrees, record the number of additional rotations required to remove the lock nut after determining the final position.

The change in angle is calculated as:

$$\theta = (t/p) \times 360^\circ$$

Where:

p : Thread pitch of lock nut, (mm)

t : Thickness of lock washer, (mm)

θ : Degrees by which the lock nut angular position must be reduced.

Installing the lock washer

After the lock nut has been removed, lubricate the contacting faces of the lock washer and lock nut. Install the lock washer between the lock nut and bearing, aligning the inside tab with the slot of the

adapter sleeve or key way in the shaft. Tighten the lock nut to the calculated position or beyond until a tab aligns. Do not loosen. Bend the lock washer tab until it seats in the notch.

Caution: Do not rotate the lock washer with the lock nut as the inside tab may break. Do not use sharp tools to bend the tab.

Vernier calipers method (Figure 13)

Measure the distance between the adapter sleeve end face and the nut end face with vernier calipers. The target value is the measured value less the plate thickness of the lock washer.

$$L = L_0 - t$$

Where:

L₀ : Measured value of distance between the sleeve end face and lock nut outer face (mm)

t : Thickness of lock washer (mm)

L : Target value (mm)

Direct check method

The radial clearance should be recorded upon setting. The lock nut is removed, the lock washer is set as recommended, and the lock nut is reinstalled securely. Ensure there is no deviation from the original recorded clearance setting.

Lock plate method (Figure 14)

When a lock plate is used for the nut, adjust the lock nut so that the nearest cutout on the outside of the lock nut mates with the slot of the adapter sleeve. Measure the radial clearance

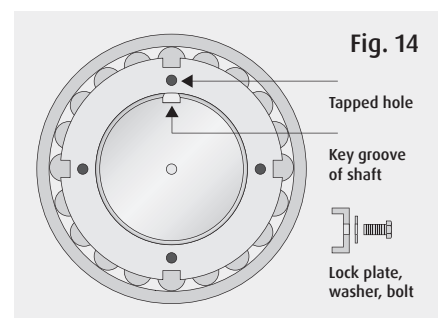
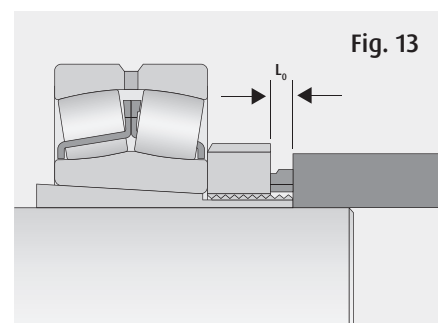
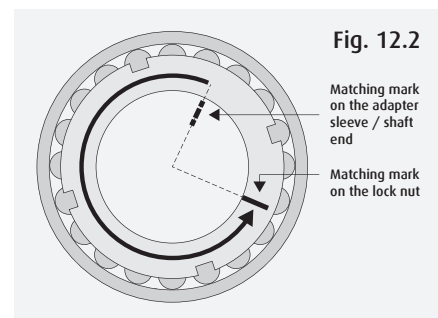
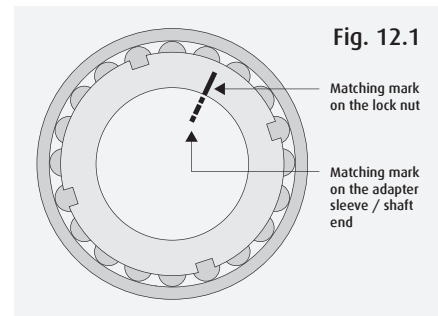

with a feeler gauge to confirm that the target radial clearance has been achieved. Insert, then fix the lock plate to the nut with the washer and bolt.

HANDLING INSTRUCTIONS FOR HYDRAULIC NUTS

Tools required: feeler gauges, portable hydraulic pump, dial indicator

The hydraulic nut is an installation tool designed to assist bearing mounting on a tapered adapter sleeve, withdrawal sleeve, or tapered shaft. After the bearing has been tightened, the hydraulic nut must be replaced with the standard lock washer and lock nut.

PROCEDURE

1. Ensure that you have the correct bearing, hydraulic nut, sleeve (if used), and tools.
2. Inspect the shaft's condition and dimensions
3. Record the following items from tables provided by the manufacturer:
 - › the internal clearance specification for the bearing
 - › the clearance reduction, starting pressure, and pushup distance for mounting
4. Using feeler gauges, measure and verify the unmounted internal clearance of the bearing. Record this measurement.



5. Clean the mating parts. Apply a thin film of low viscosity oil on the shaft and sleeve (if used).
6. Position the sleeve (if used), bearing, and any other parts (spacer, seals, etc.) loosely on the shaft as close as possible to the final desired installed position.
7. Install the hydraulic nut with the plunger toward the bearing. Turn until snug against the bearing. A bar spanner supplied with the hydraulic nut can be used to further tighten by hand. Install the spanner into the shallow hole on the outer diameter of the nut.
8. Once the nut is snug, install the dial indicator and connect the hydraulic pump to the nut.
9. Increase pressure to the hydraulic nut until the starting pressure is achieved. Zero the dial indicator.
10. Increase pressure to the hydraulic nut while measuring the internal clearance at regular intervals.

11. Continue to increase pressure until clearance reduction is achieved using the pushup distance as a guide.
12. Measure the final clearance and record this value to keep with installation details.
13. Release the pressure, measure the internal clearance to verify that it didn't change, and remove the dial indicator. Using the bar spanner, tighten the hydraulic nut to push in the plunger and return oil to the pump.
14. Disconnect the hydraulic pump and remove the hydraulic nut.
15. Install the lock washer and lock nut (the tapered side of the washer goes against the beveled side of the nut). Using the spanner wrench, tighten the nut against the bearing until snug and bend the nearest tab of the washer into a slot on the OD of the nut. If a locking clamp is used instead of a lock washer (size 44 and larger) locate the nearest locking slot so the clip fits into the notch in the adapter sleeve.



SPHERICAL ROLLER BEARINGS WITH ADAPTER SLEEVE

Method: lock nut
Shaft: cylindrical
Bearing: tapered bore
Sleeve: adapter

PROCEDURE

Begin by executing Steps 1 to 7 of **Handling Procedure - Adapter Sleeves** on **page B19**, then continue with the following steps.

8. Thread the lock nut onto the adapter sleeve without the lock washer to prevent damage to the lock washer tang due to application of heavy torque during drive-up. Advance the lock nut with the spanner wrench until it touches the bearing inner ring end face.

9. From the position where the lock nut touches the bearing inner ring end face, with the spanner wrench, continue to turn the lock nut, stopping as soon as the turning torque of the spanner wrench increases.

For a straight shaft without shoulder, back off the lock nut a little to adjust the axial position to match the specified bearing span. After axial position adjustment, turn the lock nut again with the spanner wrench and stop as soon as the turning torque increases and/or the sleeve no longer spins on the shaft. This will be the starting point for the bearing clearance adjustment

Refer to "Radial Clearance Reduction Method" on Page B11 for step 10

10. Find the nominal bore and clearance symbol of the bearing being mounted, then confirm the target **Reduction in Radial Internal Clearance** (specified value) listed in **Table 2** on **page B12**.

- › For normal (CN) clearance, target the middle of the reduction range
- › For C3 or C4 clearance, target the upper half of the reduction range
- › For light or normal loads, target the lower half of the reduction range
- › For heavy or shock loads, target the upper half of the reduction range

Fig. 15 - Spherical Roller Bearing Mounted with Adapter Sleeve on Cylindrical Shaft - Lock Nut Method

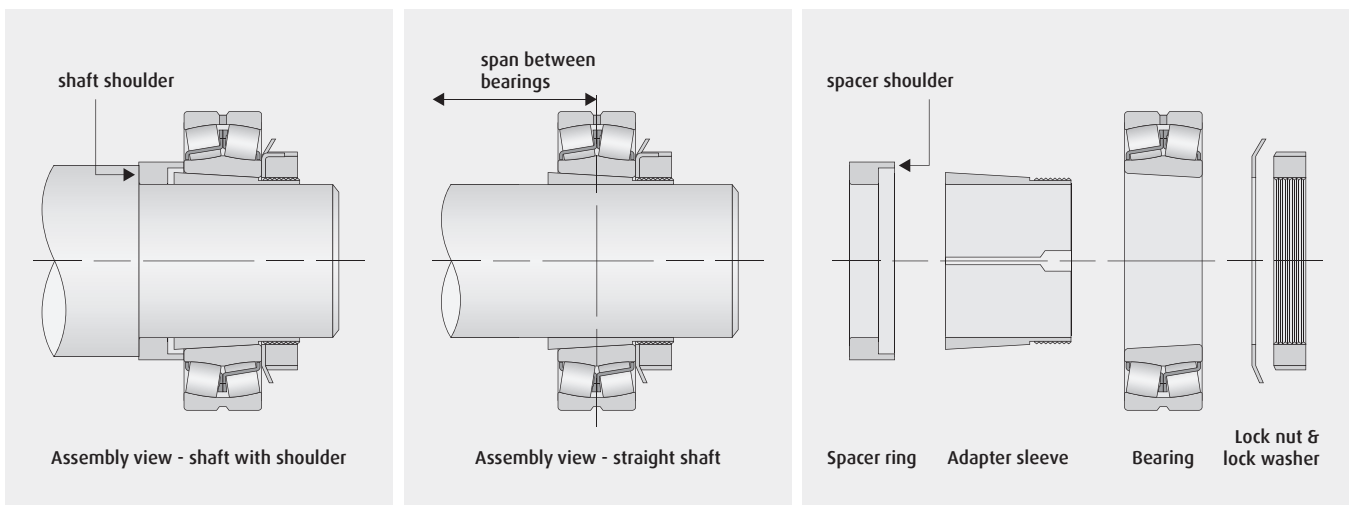

11. Turn the lock nut, measure radial internal clearance again, and repeat this operation until the radial internal clearance varies. Record this new radial clearance value, then calculate the difference between the measured initial value and the new measured value. If the obtained difference is less than the target **Reduction in Radial Internal Clearance**, continue to gradually drive the bearing up the tapered adapter by turning the nut, stopping at regular intervals to re-measure the bearing internal clearance. Repeat this operation until the target value is obtained.

Be careful to avoid driving the bearing up too far onto the tapered sleeve. If the clearance reduction amount exceeds the specified value, it may cause an improper interference and clearance that could result in inner ring fracture, abnormal temperature rise or seizure during bearing operation.



Refer to “Methods to Secure Lock Nut” on Page B20 for step 12

12. When the target **Reduction in Radial Internal Clearance** is obtained, secure the lock nut by using either a lock washer or lock plate.
13. Check to ensure that the bearing outer ring and shaft can be easily rotated by hand.

MOUNTING BEARINGS WITH TAPERED BORES

SPHERICAL ROLLER BEARINGS WITH ADAPTER SLEEVE

Method: hydraulic nut
Shaft: cylindrical
Bearing: tapered bore
Sleeve: adapter

PROCEDURE

Begin by executing Steps 1 to 7 of **Handling Procedure - Adapter Sleeves** on **page B19**, then continue with the following steps.

8. Thread the hydraulic nut onto the adapter with the plunger toward the bearing. Turn until snug against the bearing. A bar spanner supplied with the hydraulic nut can be used to further tighten by hand. Install the spanner into the shallow hole on the outer diameter of the nut.
9. Once the nut is snug, install the dial indicator and connect the hydraulic pump to the nut.
10. Increase pressure to the hydraulic nut until the starting pressure is achieved. Zero the dial indicator. This is the starting point for adjustment of the radial internal clearance.

Refer to “Axial Drive-up Method” on Page B13 for step 11

11. Confirm the target **Reduction in Radial Internal Clearance** listed in **Tables 3.1 to 3.9** on **pages B13 to B17**.
12. Increase pressure to the hydraulic nut while measuring the internal clearance at regular intervals.
13. Continue to increase pressure until clearance reduction is achieved using the drive-up distance as a guide.

Fig. 16 - Spherical Roller Bearing Mounted with Adapter Sleeve on Cylindrical Shaft - Hydraulic Nut Method

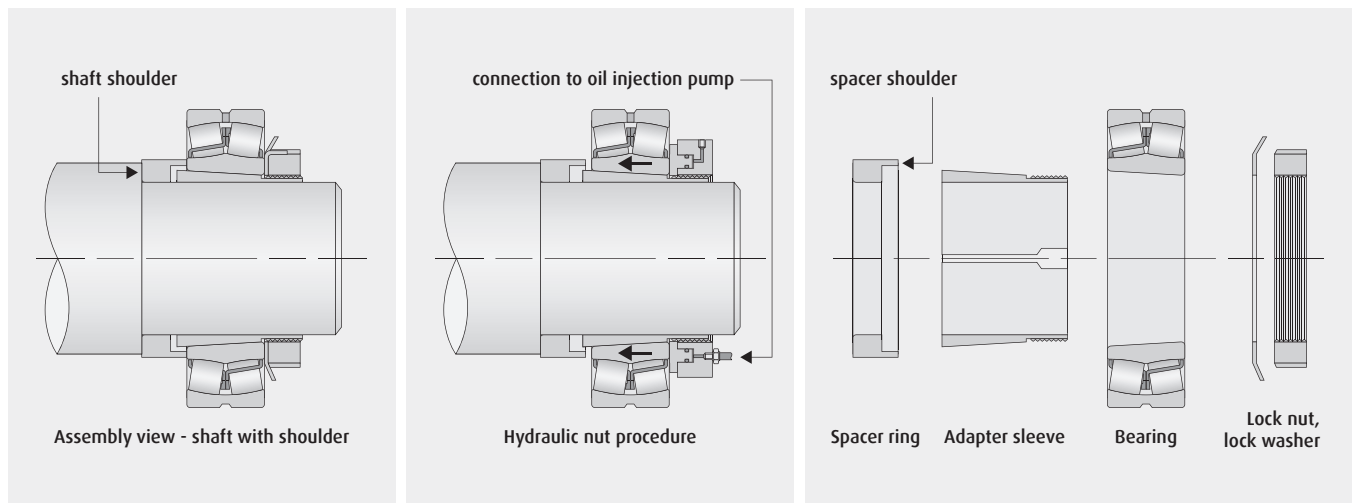



14. Measure the final clearance and record this value to keep with installation details.
15. Release the pressure, measure the internal clearance to verify that it didn't change, and remove the dial indicator. Using the bar spanner, tighten the hydraulic nut to push in the plunger and return oil to the pump.
16. Disconnect the hydraulic pump and remove the hydraulic nut.
17. Mount the lock nut with the lock washer or lock plate.
18. Check to ensure that the bearing outer ring and shaft can be easily rotated by hand.

Refer to “Methods to Secure Lock Nut” on Page B20 for step 17

MOUNTING BEARINGS WITH TAPERED BORES

SPHERICAL ROLLER BEARINGS WITH ADAPTER SLEEVE

Method: oil injection
Shaft: cylindrical
Bearing: tapered bore
Sleeve: adapter

Some adapter sleeves have oil holes (oil ducts) to assist in bearing mounting and dismounting. High pressure oil is injected via a hand operated pump into the oil hole of the adapter sleeve during mounting to temporarily expand the bearing inner ring, reducing friction. This reduces the torque necessary to turn the lock nut during drive-up of the bearing onto the adapter. For this approach to be effective, the fit between the adapter sleeve and bearing must be adequate to maintain pressure between the two tapered surfaces.

PROCEDURE

Begin by executing Steps 1 to 7 of **Handling Procedure - Adapter Sleeves** on **page B19**, then continue with the following steps.

8. Thread the lock nut onto the adapter sleeve without the lock washer to prevent damage to the lock washer tang due to application of heavy torque during drive-up. Advance the lock nut with the spanner wrench until it touches the bearing inner ring end face.

9. From the position where the lock nut touches the bearing inner ring end face, with the spanner wrench, continue to turn the lock nut, stopping as soon as the turning torque of the spanner wrench increases.

For a straight shaft without shoulder, back off the lock nut a little to adjust the axial position to match the specified bearing span. After axial position adjustment, turn the lock nut again with the spanner wrench and stop as soon as the turning torque increases and/or the sleeve no longer spins on the shaft. This will be the starting point for the bearing clearance adjustment.

Fig. 17 - Spherical Roller Bearing Mounted with Adapter Sleeve on Cylindrical Shaft - Oil Injection Method

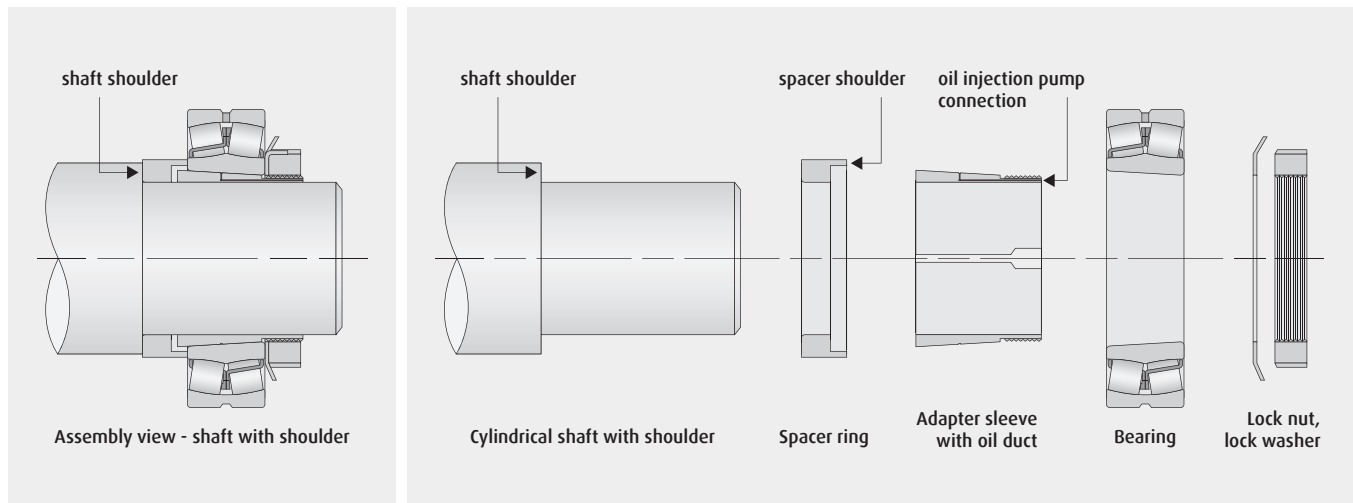

Refer to “Radial Clearance Reduction Method” on Page B11 for step 10

10. Find the nominal bore and clearance symbol of the bearing being mounted, then confirm the target **Reduction in Radial Internal Clearance** (specified value) listed in **Table 2** on **page B12**.
 - › For normal (CN) clearance, target the middle of the reduction range
 - › For C3 or C4 clearance, target the upper half of the reduction range
 - › For light or normal loads, target the lower half of the reduction range
 - › For heavy or shock loads, target the upper half of the reduction range
11. Connect the oil injection pump hose to the threaded oil hole (oil duct) of the adapter sleeve. Start the oil injection pump and begin incrementally turning the lock nut with the spanner wrench to drive up the bearing onto the adapter sleeve.

12. After each increment of drive-up, measure radial internal clearance again, and repeat this operation until the radial internal clearance changes. Record this new radial clearance value, then calculate the difference between the measured initial value and the new measured value. If this difference is less than the target **Reduction in Radial Internal Clearance**, continue to gradually drive up the bearing onto the tapered adapter with the spanner wrench (while running the oil injection pump), stopping at regular intervals to re-measure the bearing internal clearance. Repeat this operation until the target value is obtained.

Stop the pump, bleed down the oil injection pressure, and re-measure the bearing internal clearance to confirm the **Reduction in Radial Internal Clearance**. Re-start the pump and drive up the bearing further onto the adapter as necessary to reach the target **Reduction in Radial Internal Clearance** with oil injection pressure at zero.

Be careful to avoid driving the bearing up too far onto the tapered sleeve. If the clearance reduction amount exceeds the specified value, it may cause an improper interference and clearance that could result in inner ring fracture, abnormal temperature rise or seizure during bearing operation.

13. When the target **Reduction in Radial Internal Clearance** is obtained, disconnect the oil injection pump hose from the hydraulic nut and stop turning the lock nut. Mount the lock nut with the lock washer or lock plate.

Refer to “Methods to Secure Lock Nut” on Page B20 for step 13

14. Check to ensure that the bearing outer ring and shaft can be easily rotated by hand.

MOUNTING BEARINGS WITH TAPERED BORES

SPHERICAL ROLLER BEARINGS WITH WITHDRAWAL SLEEVE

Method: lock nut
Shaft: cylindrical
Bearing: tapered bore
Sleeve: withdrawal

PROCEDURE

Begin by executing Steps 1 to 8 of **Handling Procedure - Withdrawal Sleeves** on **page B19**, then continue with the following steps.

9. Thread the lock nut onto the shaft and turn it with the spanner wrench until it contacts the bearing inner ring.

10. With the spanner wrench, continue to turn the lock nut, stopping as soon as the turning torque increases and/or the sleeve no longer spins on the shaft. This is the starting point for adjustment of the radial internal clearance.

11. Find the nominal bore and clearance symbol of the bearing being mounted, then confirm the target **Reduction in Radial Internal Clearance** (specified value) listed in **Table 2** on **page B12**.

- › For normal (CN) clearance, target the middle of the reduction range
- › For C3 or C4 clearance, target the upper half of the reduction range

Refer to “Radial Clearance Reduction Method” on Page B11 for step 11

- › For light or normal loads, target the lower half of the reduction range
- › For heavy or shock loads, target the upper half of the reduction range

Fig. 18 - Spherical Roller Bearing Mounted with Withdrawal Sleeve on Cylindrical Shaft - Lock Nut Method

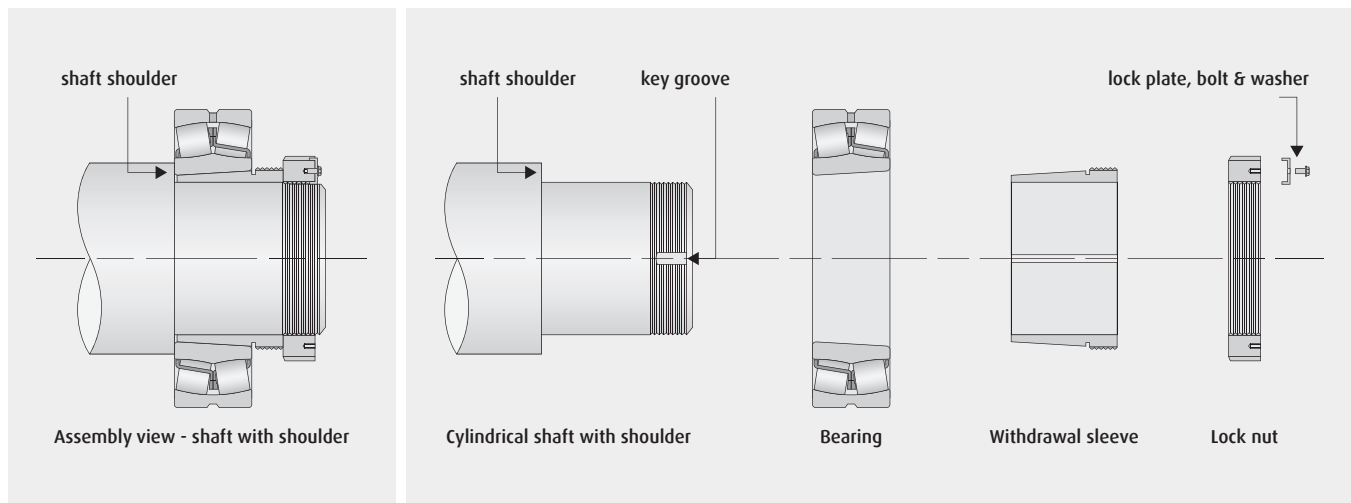

12. Turn the lock nut, measure radial internal clearance again, and repeat this operation until the radial internal clearance varies. Record this new radial clearance value, then calculate the difference between the measured initial value and the new measured value. If the obtained difference is less than the target **Reduction in Radial Internal Clearance**, continue to gradually push the bearing onto the tapered adapter by turning the nut, stopping at regular intervals to re-measure the bearing internal clearance. Repeat this operation until the target value is obtained.

Be careful to avoid driving the bearing up too far onto the tapered sleeve. If the clearance reduction amount exceeds the specified value, it may cause an improper interference and clearance that could result in inner ring fracture, abnormal temperature rise or seizure during bearing operation.



Refer to “Methods to Secure Lock Nut” on Page B20 for step 13

13. When the target **Reduction in Radial Internal Clearance** is obtained, secure the lock nut by using either a lock washer or lock plate.
14. Check to ensure that the bearing outer ring and shaft can be easily rotated by hand.

MOUNTING BEARINGS WITH TAPERED BORES

SPHERICAL ROLLER BEARINGS WITH WITHDRAWAL SLEEVE

Method: hydraulic nut
Shaft: cylindrical
Bearing: tapered bore
Sleeve: withdrawal

PROCEDURE

Begin by executing Steps 1 to 8 of **Handling Procedure - Withdrawal Sleeves** on **page B19**, then continue with the following steps.

9. Thread the hydraulic nut onto the shaft with the plunger toward the bearing. Turn until snug against the withdrawal sleeve. A bar spanner supplied with the hydraulic nut can be used to further tighten by hand. Install the spanner into the shallow hole on the outer diameter of the nut.
10. Once the nut is snug, install the dial indicator and connect the hydraulic pump to the nut.
11. Increase pressure to the hydraulic nut until the starting pressure is achieved. Zero the dial indicator. This is the starting point for adjustment of the radial internal clearance.

Refer to “Axial Drive-up Method” on Page B13 for step 12

12. Confirm the target **Reduction in Radial Internal Clearance** listed in **Tables 3.1 to 3.9** on **pages B13 to B17**.
13. Increase pressure to the hydraulic nut while measuring the internal clearance at regular intervals.

Fig. 19 - Spherical Roller Bearing Mounted with Withdrawal Sleeve on Cylindrical Shaft - Hydraulic Nut Method

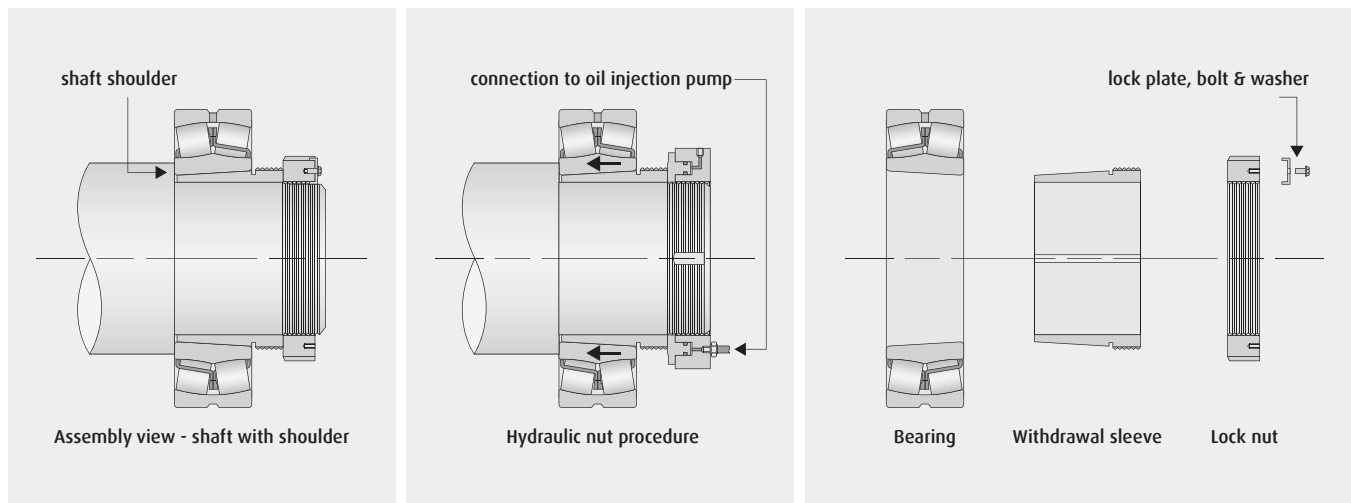



14. Continue to increase pressure until clearance reduction is achieved using the drive-up distance as a guide.
15. Measure the final clearance and record this value to keep with installation details.
16. Release the pressure, measure the internal clearance to verify that it didn't change, and remove the dial indicator. Using the bar spanner, tighten the hydraulic nut to push in the plunger and return oil to the pump.
17. Disconnect the hydraulic pump and remove the hydraulic nut.

Refer to “Methods to Secure Lock Nut” on Page B20 for step 18

18. Mount the lock nut with the lock washer or lock plate.
19. Check to ensure that the bearing outer ring and shaft can be easily rotated by hand.

SPHERICAL ROLLER BEARINGS WITH WITHDRAWAL SLEEVE

Method: oil injection
Shaft: cylindrical
Bearing: tapered bore
Sleeve: withdrawal

Some withdrawal sleeves have oil holes (oil ducts) to assist in bearing mounting and dismounting. High pressure oil is injected via a hand operated pump into the oil hole of the withdrawal sleeve during mounting to temporarily expand the bearing inner ring, reducing friction. This reduces the torque necessary to turn the lock nut during drive-up of the bearing onto the adapter. For this approach to be effective, the fit between the withdrawal sleeve and the shaft and bearing must be adequate to maintain pressure between the surfaces.

The withdrawal sleeve must be held onto the shaft by an end plate or end cap with a cutout to allow access to the oil port of the withdrawal sleeve. The end plate or cap is secured to the shaft with bolts that thread into holes cut into the shaft end. A nut cannot be easily used here, since it will block the oil port of the withdrawal sleeve.

The end plate or cap bolts are used to drive up the bearing onto the withdrawal sleeve, setting the radial internal clearance. It is not unusual for the bolt torque to be high, so use bolts with appropriate strength.

PROCEDURE

Begin by executing Steps 1 to 8 of **Handling Procedure - Withdrawal Sleeves** on **page B19**, then continue with the following steps.

9. To facilitate connection of the oil injection pump hose, orient the cutout on the end cap to match the oil hole on the removable sleeve. Mount the end cap on the shaft with the fixing bolts. If spring washers are used with the fixing bolts, insert the spring washers at this time.
10. Tighten all the bolts finger-tight, then starting with one bolt, tighten until a torque increase is felt. Next, tighten the bolt opposite the first bolt until a torque increase is felt. Continue with the remaining bolts, alternating from one side of the end cap to the other until all of the bolts are tightened to the same torque.

Fig. 20 - Spherical Roller Bearing Mounted with Withdrawal Sleeve on Cylindrical Shaft - Oil Injection Method

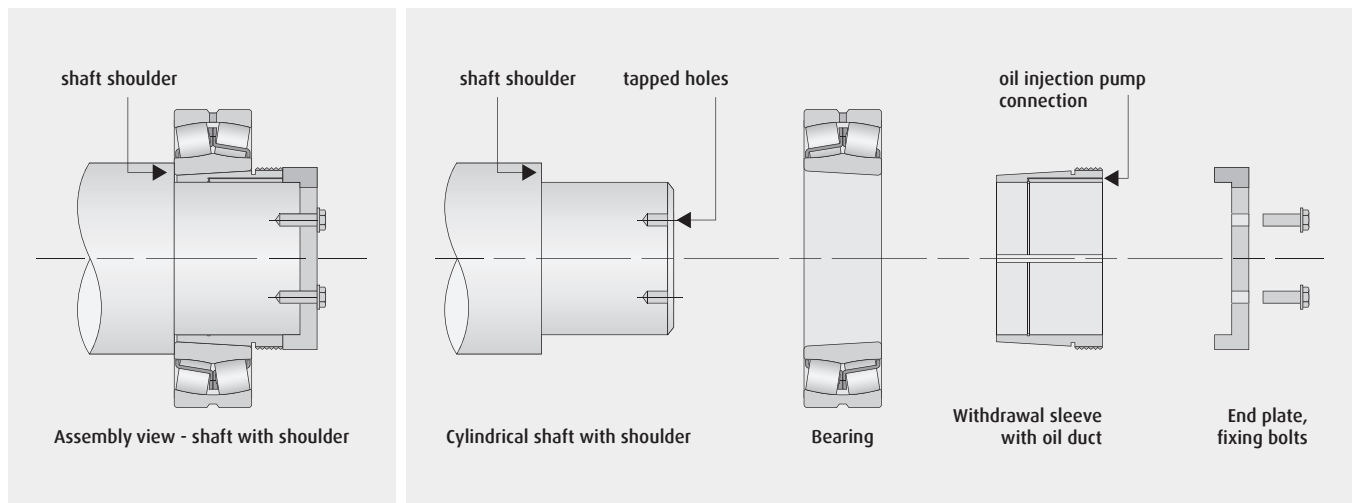

Refer to “Radial Clearance Reduction Method” on Page B11 for step 11

11. Find the nominal bore and clearance symbol of the bearing being mounted, then confirm the target **Reduction in Radial Internal Clearance** (specified value) listed in **Table 2** on **page B12**.
 - › For normal (CN) clearance, target the middle of the reduction range
 - › For C3 or C4 clearance, target the upper half of the reduction range
 - › For light or normal loads, target the lower half of the reduction range
 - › For heavy or shock loads, target the upper half of the reduction range
 12. Evenly tighten the end cap bolts to drive the withdrawal sleeve further into the bearing, then measure radial internal clearance again. Repeat this operation until the radial internal clearance varies. Record this new radial clearance value.
 13. Connect the oil injection pump hose to the threaded oil hole (oil duct) on the withdrawal sleeve. Start the oil injection pump and begin incrementally driving up the bearing onto the withdrawal sleeve by evenly tightening the end cap bolts.
 14. After each increment of drive-up, measure radial internal clearance again. Record this new radial clearance value, then calculate the difference between the measured initial value and the new measured value. If this difference is less than the target **Reduction in Radial Internal Clearance** continue to gradually drive the withdrawal sleeve into the bearing by evenly tightening the end plate or cap bolts (while running the oil injection pump), stopping at regular intervals to re-measure the bearing internal clearance. Repeat this operation until the target value is obtained.
- Stop the pump, bleed down the oil injection pressure, and re-measure the bearing internal clearance to confirm the **Reduction in Radial Internal Clearance**. Re-start the pump and drive up the bearing further onto the adapter as necessary to reach the target **Reduction in Radial Internal Clearance** with oil injection pressure at zero.
- Be careful to avoid driving the bearing up too far onto the withdrawal sleeve. If the clearance reduction amount exceeds the specified value, it may cause an improper interference and clearance that could result in inner ring fracture, abnormal temperature rise or seizure during bearing operation.
15. When the specified value is obtained, disconnect the oil injection pump hose from the hydraulic nut and stop tightening the end cap bolts. If the fixing bolts have holes for safety wire drilled in their heads, insert safety wire to secure the bolts against loosening.
 16. Check to ensure that the bearing outer ring and shaft can be easily rotated by hand.

SPHERICAL ROLLER BEARINGS - DIRECT SHAFT MOUNT

Method: lock nut
Shaft: tapered
Bearing: tapered bore
Sleeve: none

PROCEDURE

1. Wipe the surface of the shaft with clean oil to remove dirt.
2. Verify that the shaft taper is within specification. Use a sine bar and bluing compound to facilitate measurements of the taper's pitch and surface. The contact area should be at least 80%. Refer to **Checking of Tapered Shafts** on page B51.
3. Measure the bearing internal clearance and record the measured clearance value. This is the Measured Initial Clearance.
4. Mount the bearing with the taper oriented to match the shaft taper. For shafts with shoulders for use with spacers (see Fig. 21), proceed with bearing adjustment without the spacer installed. The spacer will be installed after radial clearance adjustment of the bearing.
5. Thread the lock nut onto the shaft without the lock washer to prevent damage to the lock washer tang due to application of heavy torque during drive-up. Advance the lock nut with the spanner wrench until it touches the bearing inner ring end face.

6. From the position where the lock nut touches the bearing inner ring end face, with the spanner wrench, continue to turn the lock nut, stopping as soon as the turning torque of the spanner wrench increases. This will be the starting point for the bearing clearance adjustment.

7. Find the nominal bore and clearance symbol of the bearing being mounted, then confirm the target **Reduction in Radial Internal Clearance** (specified value) listed in **Table 2** on page B12.
 - › For normal (CN) clearance, target the middle of the reduction range
 - › For C3 or C4 clearance, target the upper half of the reduction range
 - › For light or normal loads, target the lower half of the reduction range
 - › For heavy or shock loads, target the upper half of the reduction range



Refer to “Radial Clearance Reduction Method” on Page B11 for step 7

- Turn the lock nut, measure radial internal clearance again, and repeat this operation until the radial internal clearance varies. Record this new radial clearance value, then calculate the difference between the measured initial value and the new measured value. If the obtained difference is less than the target **Reduction in Radial Internal Clearance**, continue to gradually push the bearing onto

the tapered shaft by turning the nut, stopping at regular intervals to re-measure the bearing internal clearance. Repeat this operation until the target value is obtained.

Be careful to avoid driving the bearing up too far onto the tapered shaft. If the clearance reduction amount exceeds the specified value, it may cause an improper interference and clearance that could result in inner ring fracture, abnormal temperature rise or seizure during bearing operation.

*If a spacer ring will be used in the final assembly, proceed to **When a Spacer Ring is Used** on page B37.

Refer to “Methods to Secure Lock Nut” on Page B20 for step 9

- When the target **Reduction in Radial Internal Clearance** is obtained, secure the lock nut by using either a lock washer or lock plate.
- Check to ensure that the bearing outer ring and shaft can be easily rotated by hand.

Fig. 21 - Spherical Roller Bearing Mounted on Tapered Shaft - Lock Nut Method

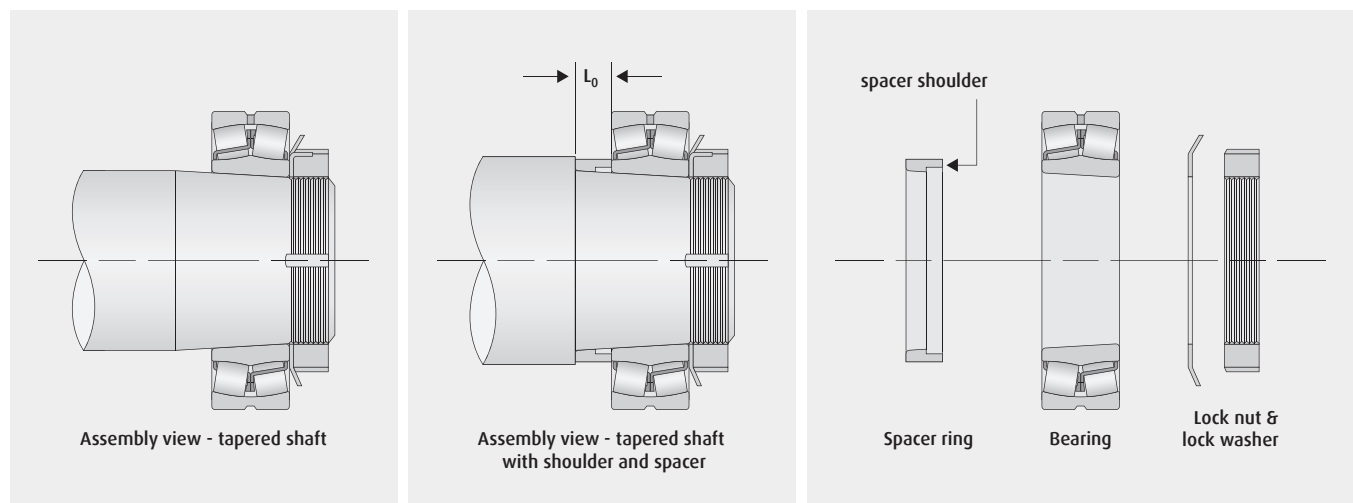

SPHERICAL ROLLER BEARINGS - DIRECT SHAFT MOUNT

Method: lock nut
Shaft: tapered
Bearing: tapered bore
Sleeve: none

WHEN A SPACER RING IS USED

Measure the gap (see “L₀”, **Figure 21** on **page B36**) between the end face of the shaft shoulder and the end face of the bearing inner ring at 8 evenly distributed positions 45 degrees apart. Calculate the mathematical mean value of the measured dimensions.

Measure the width of the spacer ring at 8 evenly distributed positions and calculate the mathematical mean value of the spacer ring width.

Compare the mathematical mean value of the gap and the spacer ring width to determine whether the spacer ring width matches the gap width. If the spacer ring is wider than the gap, it must be ground to match the width of the gap. If the spacer is already narrower than the gap width, a new spacer ring must be made to match the width of the gap.

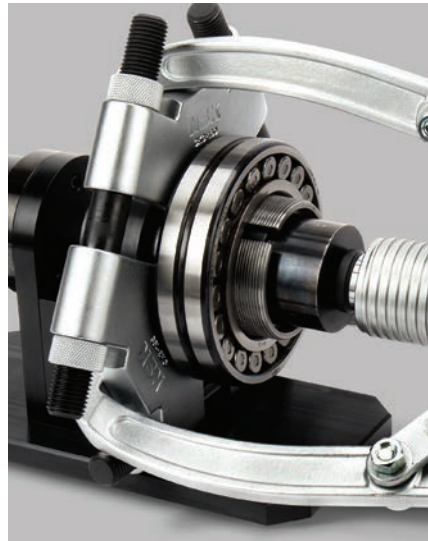

After confirming the correct width of the spacer ring, perform the following steps.

9. Back off the lock nut with a spanner wrench, leaving the lock nut still threaded onto the end of the shaft.
10. Temporarily remove the bearing using a bearing puller. Mount a 3-jaw puller plate between the shaft shoulder and the bearing. The puller plate must only contact the inner ring of the bearing, not the outer ring. Set up the bearing puller to pull on the puller plate while the threaded shaft pushes against the end of the shaft. Use a safety net as a preventative measure against any parts breaking free while pulling.
11. With the bearing loose, completely remove the lock nut and remove the bearing from the shaft.
12. Mount the spacer ring using the orientation shown in **Figure 21**.
13. Re-install the bearing and lock nut. The bearing is located in the proper position when it is pushed up tight to the correct spacer width.
14. Secure the lock nut by using either a lock washer or lock plate.
15. Check to ensure that the bearing outer ring and shaft can be easily rotated by hand.

Method: hydraulic nut
Shaft: tapered
Bearing: tapered bore
Sleeve: none

PROCEDURE

1. Wipe the surface of the shaft with clean oil to remove dirt.
2. Verify that the shaft taper is within specification. Use a sine bar and bluing compound to facilitate measurements of the taper's pitch and surface. The contact area should be at least 80%. Refer to **Checking of Tapered Shafts** on page B51.
3. Measure the bearing internal clearance and record the measured clearance value. This is the Measured Initial Clearance.
4. Mount the bearing with the taper oriented to match the shaft taper.
5. Thread the hydraulic nut onto the shaft with the plunger toward the bearing. Turn until snug against the bearing. A bar spanner supplied with the hydraulic nut can be used to further tighten by hand. Install the spanner into the shallow hole on the outer diameter of the nut.
6. Once the nut is snug, install the dial indicator and connect the hydraulic pump to the nut.
7. Increase pressure to the hydraulic nut until the starting pressure is achieved. Zero the dial indicator. This is the starting point for adjustment of the radial internal clearance.
8. Confirm the target **Reduction in Radial Internal Clearance** listed in **Tables 3.1 to 3.9** on pages B13 to B17.
9. Increase pressure to the hydraulic nut while measuring the internal clearance at regular intervals.
10. Continue to increase pressure until clearance reduction is achieved using the drive-up distance as a guide.
11. Measure the final clearance and record this value to keep with installation details.

Refer to "Axial Drive-up Method" on Page B13 for step 8

12. Release the pressure, measure the internal clearance to verify that it didn't change, and remove the dial indicator. Using the bar spanner, tighten the hydraulic nut to push in the plunger and return oil to the pump.
13. Mount the lock nut with the lock washer or lock plate.
14. Check to ensure that the bearing outer ring and shaft can be easily rotated by hand.

Fig. 22 - Spherical Roller Bearing Mounted on Tapered Shaft - Hydraulic Nut Method

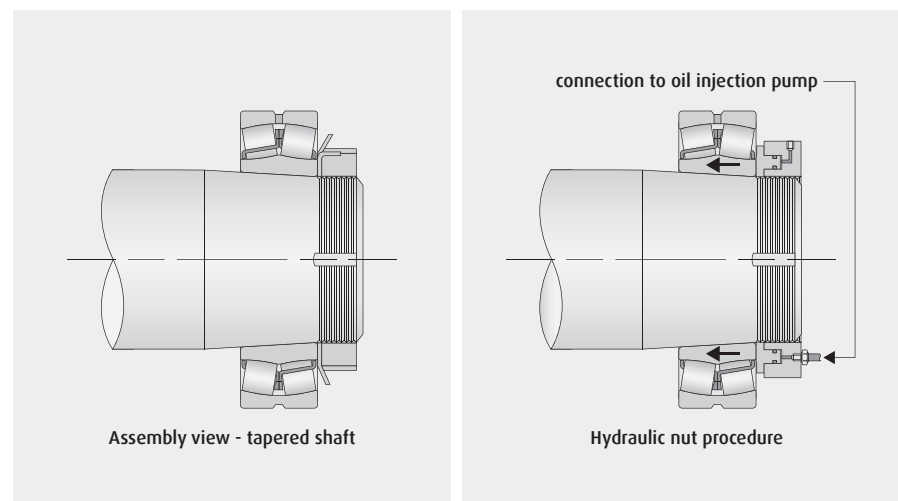

MOUNTING BEARINGS WITH TAPERED BORES

SELF-ALIGNING BALL BEARINGS WITH ADAPTER SLEEVE

Method: axial drive-up

PROCEDURE

Begin by executing Steps 1 to 7 of **Handling Procedure - Adapter Sleeves** on **page B19**, then continue with the following steps.

- Slide bearing, lock washer and lock nut onto sleeve and tighten nut with a spanner wrench until all slackness is removed.
- Measure distance from end tapered sleeve to the face of lock nut or to the face of the inner ring and note the dimension.
- Refer to **Tables 5 and 6** on **pages B41 - 42** and tighten the lock nut until the bearing has moved the required distance up the taper of the sleeve indicated by the reduction or increase in the measured distance originally noted.

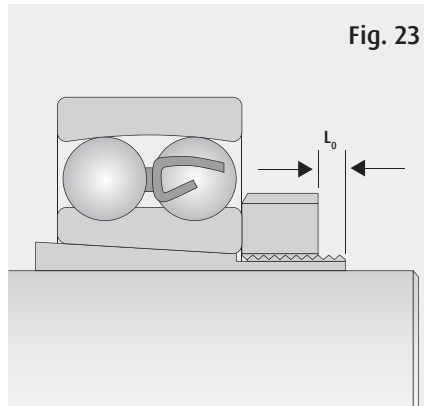

11. A self-aligning ball bearing with normal clearance when adjusted correctly should rotate freely but should have some resistance to swiveling.



12. Align one tab on the lock washer with a slot in the lock nut and bend it into the slot. If no tabs line up with the slots, slightly tighten the lock nut until one aligns. Never back off the nut to line up the tab with the slot.

Method: tightening angle

PROCEDURE

Begin by executing Steps 1 to 7 of **Handling Procedure - Adapter Sleeves** on **page B19**, then continue with the following steps.

8. Slide bearing, lock washer and lock nut onto sleeve and tighten nut with a spanner wrench until all slackness is removed.
9. Refer to **Tables 5 and 6** on **pages B41 - 42** and tighten the lock nut through the required angle, taken from chart.

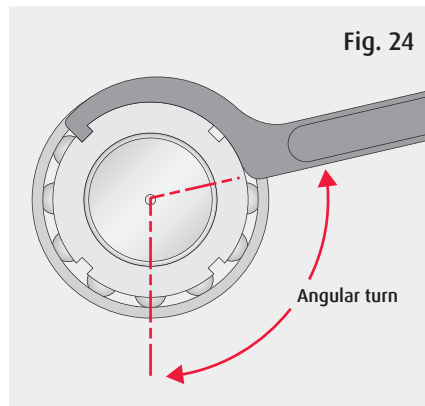

10. A self-aligning ball bearing with normal clearance when adjusted correctly should rotate freely but should have some resistance to swiveling.
11. Align one tab on the lock washer with a slot in the lock nut and bend it into the slot. If no tabs line up with the slots, slightly tighten the lock nut until one aligns. Never back off the nut to line up the tab with the slot.

Fig. 25 - Self-aligning Ball Bearing Mounted with Adapter Sleeve on Cylindrical Shaft - Lock Nut Method

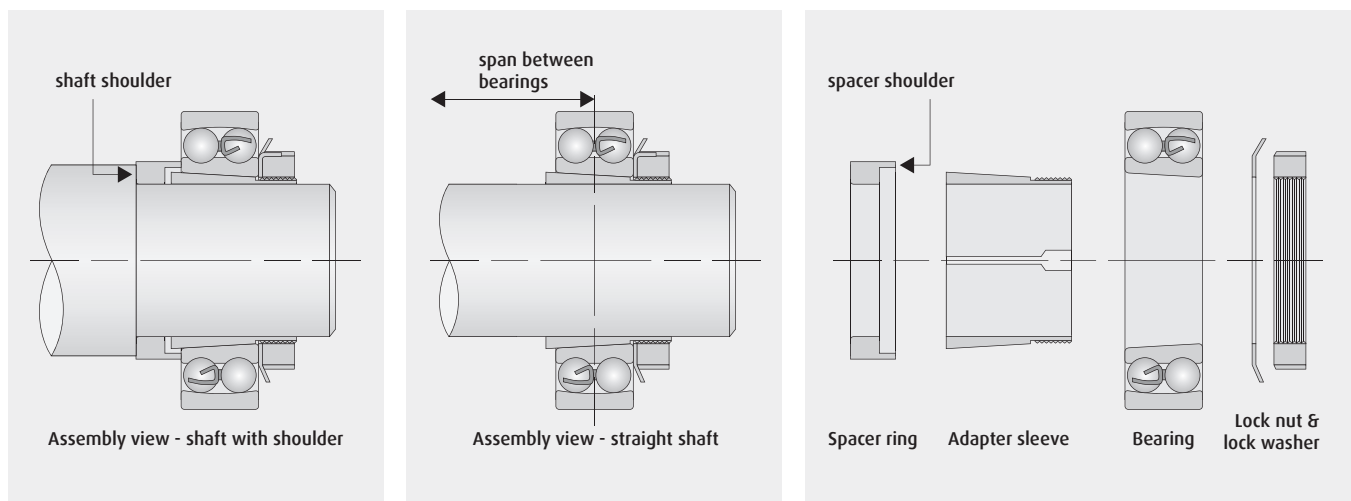

MOUNTING BEARINGS WITH TAPERED BORES

SELF-ALIGNING BALL BEARINGS WITH ADAPTER SLEEVE

Table 5 - Axial and Angular Drive-up for Self-aligning Ball Bearings - Inch Lock Nut

BORE DIAMETER (MM)	INCH LOCK NUT	AXIAL DISPLACEMENT (INCH)				ANGULAR TURN (DEGREES)			
		12K	13K	22K	23K	12K	13K	22K	23K
20	N04	0.006	0.006	0.007	0.006	70	70	75	70
25	N05	0.007	0.007	0.008	0.007	80	85	90	80
30	N06	0.007	0.007	0.008	0.007	45	45	50	45
35	N07	0.009	0.009	0.010	0.009	60	55	60	55
40	N08	0.009	0.009	0.010	0.009	60	55	60	55
45	N09	0.010	0.010	0.011	0.010	65	65	65	60
50	N10	0.010	0.010	0.011	0.010	65	65	65	60
55	N11	0.013	0.013	0.013	0.012	80	80	85	75
60	N12	0.013	0.013	0.013	0.012	80	80	85	75
65	N13	0.013	0.013	0.013	0.012	80	80	85	75
70	N14	0.017	0.017	0.017	0.016	105	105	110	100
75	AN15	0.017	0.017	0.017	0.016	70	70	70	65
80	AN16	0.017	0.017	0.017	0.016	70	70	70	65
85	AN17	0.020	0.019	0.020	0.019	85	80	85	80
90	AN18	0.020	0.019	0.020	0.019	85	80	85	80
95	AN19	0.020	0.019	0.020	0.019	85	80	85	80
100	AN20	0.020	0.019	0.020	0.019	85	80	85	80
110	AN22	0.024	0.023	0.025	-	100	95	105	-

Table 6 - Axial and Angular Drive-up for Self-aligning Ball Bearings - Metric Lock Nut

BORE DIAMETER (MM)	INCH LOCK NUT	AXIAL DISPLACEMENT (INCH)				ANGULAR TURN (DEGREES)			
		12K	13K	22K	23K	12K	13K	22K	23K
20	KM4	0.160	0.160	0.170	0.160	55	55	60	55
25	KM5	0.180	0.190	0.200	0.180	40	45	45	40
30	KM6	0.180	0.190	0.200	0.180	40	45	45	40
35	KM7	0.240	0.230	0.250	0.220	55	55	60	50
40	KM8	0.240	0.230	0.250	0.220	55	55	60	50
45	KM9	0.260	0.260	0.270	0.250	60	60	60	60
50	KM10	0.260	0.260	0.270	0.250	60	60	60	60
55	KM11	0.330	0.320	0.340	0.310	55	55	60	55
60	KM12	0.330	0.320	0.340	0.310	55	55	60	55
65	KM13	0.330	0.320	0.340	0.310	55	55	60	55
70	KM14	0.420	0.420	0.440	0.400	75	75	75	70
75	KM15	0.420	0.420	0.440	0.400	75	75	75	70
80	KM16	0.420	0.420	0.440	0.400	75	75	75	70
85	KM17	0.510	0.490	0.510	0.480	90	85	90	85
90	KM18	0.510	0.490	0.510	0.480	90	85	90	85
95	KM19	0.510	0.490	0.510	0.480	90	85	90	85
100	KM20	0.510	0.490	0.510	0.480	90	85	90	85
110	KM22	0.610	0.580	0.630	-	105	100	110	-

MOUNTING PILLOW BLOCKS AND SEALS

Installing SAF series split pillow blocks

PROCEDURE

1. Inspect the shaft condition for any burrs. Wipe the shaft with a clean cloth.
2. Verify the diameter of the shaft. Refer to **Table 9** on **page C15** for the diameter tolerance of the shaft.
3. Add seals to the inboard side of the shaft. This must be done prior to mounting the bearing. Refer to the seal mounting instructions for TER and OLB seals on **page B46**.
4. Mount the bearing, referring to the various mounting instructions for spherical roller bearings and self-aligning ball bearings on **pages B23 to B40**.
5. Attach seal to the outboard side of the shaft.
6. Position bottom half of the pillow block unit to its mounted location. Carefully lower the mounted bearing and seals into the unit.



Fig. 26 - SAF Pillow Block Assembly with Spherical Roller Bearing and OLB Seal

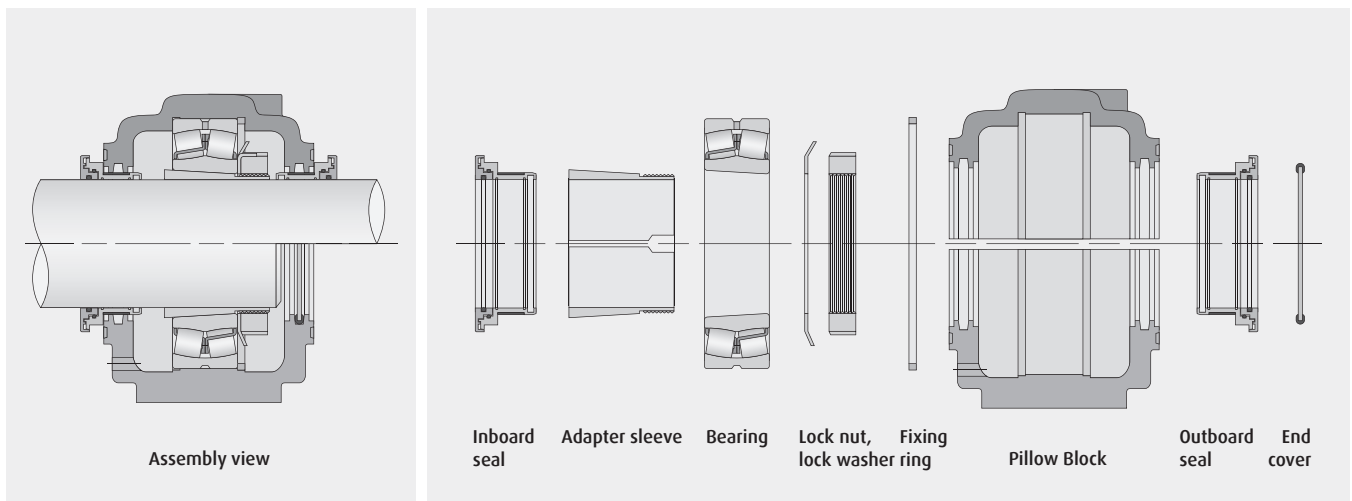



7. If grease lubrication is to be used, apply grease to the bearing. Work the grease into the bearing and add until the bottom half of the pillow block is about 1/3 to 1/2 full.
8. Identify if the bearing will be used as a fixed or expansion (float) set. If the bearing is fixed, leave the fixing ring in the unit. If it is an expansion end, remove and discard the fixing ring and ensure the bearing is centered in the housing seat.
9. Attach the upper half of the pillow block unit to the housing. Lightly apply oil to the bearing contact surfaces. (Note: caps and bases of pillow block units are not interchangeable). Tighten bolts to the torque specified in **Table 7** on **page B45**.

MOUNTING PILLOW BLOCKS AND SEALS

**Table 7 - Recommended Tightening Torque
SAF Pillow Block**

SAF PILLOW BLOCK SIZE	RECOMMENDED TIGHTENING TORQUE FOR CAP BOLTS		
	Bolt Size	Qty	Torque (ft-lbf)
509	3/8-16 UNC x 2	2	26
510	3/8-16 UNC x 2	2	26
511	1/2-13 UNC x 2 1/4	2	50
513	1/2-13 UNC x 2 1/4	2	50
515	1/2-13 UNC x 2 1/4	2	50
516	1/2-13 UNC x 2 1/4	4	50
517	1/2-13 UNC x 3	4	50
518	1/2-13 UNC x 3	4	50
520	5/8-11 UNC x 3 1/2	4	100
522	5/8-11 UNC x 3 1/2	4	100
524	5/8-11 UNC x 4	4	100
526	3/4-10 UNC x 4 1/2	4	175
528	3/4-10 UNC x 4 1/2	4	175
530	3/4-10 UNC x 5	4	175
532	3/4-10 UNC x 5	4	175
534	1-8 UNC x 6 1/2	4	245
536	1-8 UNC x 6 1/2	4	245
538	1-8 UNC x 6 1/2	4	245
540	1-8 UNC x 7	4	245
544	1-8 UNC x 7 1/2	4	245

**Table 8 - Recommended Initial Grease Fill
SAF Pillow Block**

SAF PILLOW BLOCK SIZE	RECOMMENDED INITIAL GREASE FILL (OZ)	
	Low Speed	High Speed
509	2.2	1.8
510	2.8	2
511	3.7	2.5
513	6.5	4
515	8.3	5
516	10	6
517	12	7
518	16	7.5
520	23	15
522	31	20
524	37	22
526	40	28
528	52	32
530	62	34
532	75	40
534	90	55
536	120	65
538	150	75
540	200	85
544	250	125

For data pertaining to additional series SAF pillow blocks, contact NSK.

- (1) Low speed applications Typically involve conveyors. Generally, bearings exposed to weather benefit from a relatively full grease charge to deter moisture ingress.
- (2) Higher speed applications do not require as much grease, as purging of excess will occur at the seals naturally.

Installing TER seals (Fig. 27)

PROCEDURE

1. Soak the felt strips in a lightweight oil for a few minutes. After soaking, insert into the internal seal groove nearest to the bearing. The strips may need to be trimmed to length.
2. Hand pack the grease groove with the same grease to be used in the bearing.
3. Lightly grease or oil the shaft and bore of the inboard seal to protect the shaft. Carefully slide the inboard seal onto the shaft, but clear of the bearing area.
4. Finish mounting the bearing onto the shaft.
5. Apply grease by hand to the seal grooves of the housing where the TER-OS seal will fit. This will help begin to form the contamination barrier.
6. Lower the assembled bearing, seal and shaft into the housing base. Adjust the seal position along the shaft to fit into the designated seal groove. Lubricate the bearing as specified in Table 8.

7. Attach the housing cap and tighten the cap bolts as specified in Table 7. The seal should be a tight fit.
8. Add a small amount of grease to the seal lubrication fittings to ensure the internal cavities of the seal are full. Slight grease purge from the seal showing fresh grease is preferred.
9. Relubricate the seals as often as needed. Fresh grease purge is the best way to prevent contaminant entry.

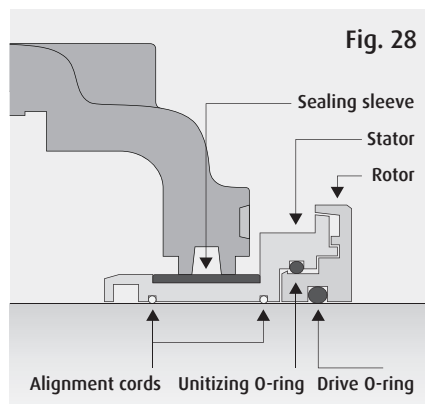
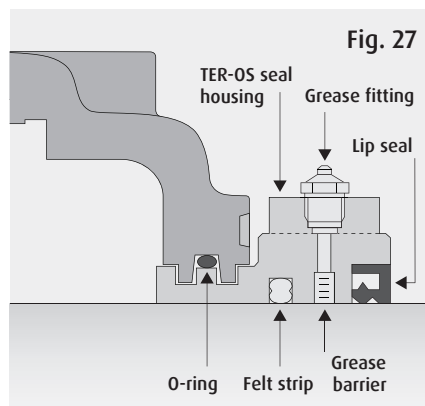

Installing OLB seals (Fig. 28)

PROCEDURE

1. In the case of a damaged bore internal diameter surface, and if the seal design does not include a stator o-ring, apply a thin layer of RTV sealant onto the stator insertion outside diameter surface.
2. Line up the contaminant exclusion port with the 6 o'clock position on the cover or housing. Using a hand arbor press or direct even pressure, apply force on the inner half of the rotor face until the bearing protective device stops at the location shoulder.
3. Lightly lubricate the shaft with the lubrication supplied. If more lubrication is needed, use a diluted mixture of liquid hand soap and water. Do not use a grease-based lubricant. While holding the cover assembly or seal alone, push on the rotor face and slide the cover assembly into position.
4. Secure the cover into place. Push firmly on the rotor to ensure full rotor/stator engagement.
5. Turn the shaft to confirm smooth operation.

Note: If the rotor and stator become separated, the rotor can be re-engaged with the stator after the cover is secured in place.

MOUNTING BALL BEARING UNITS

Installing set screw locking arrangements (Fig.29)

PROCEDURE

1. Loosen set screws clear of the bearing bore and slide the mounted unit onto the shaft.
2. Install the mounting bolts and tighten to secure mounted unit to the equipment.
3. Tighten set screws on the bearing inner ring to the recommended torque. (see **Table 9**)

Fig. 29

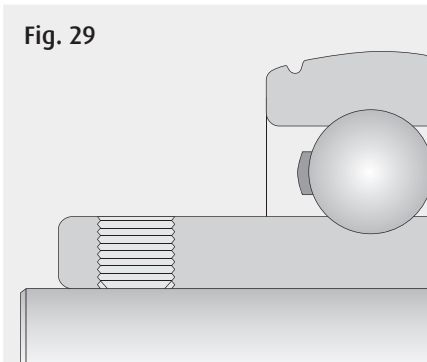

Installing eccentric locking collar locking arrangements (Fig. 30)

PROCEDURE

1. Remove the eccentric locking collar and slide the mounted unit onto the shaft.
2. Install the mounting bolts and tighten to secure mounted unit to the equipment.
3. Loosen the eccentric locking collar set screw clear of the collar bore and install onto bearing unit.
4. Engage the eccentric locking collar in the direction of shaft rotation.
5. Tighten eccentric locking collar with a drift pin and a small hammer.
6. Tighten eccentric locking collar set screw to the recommended torque. (see **Table 9**)

Fig. 30

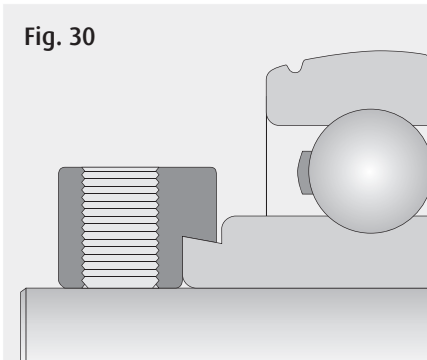
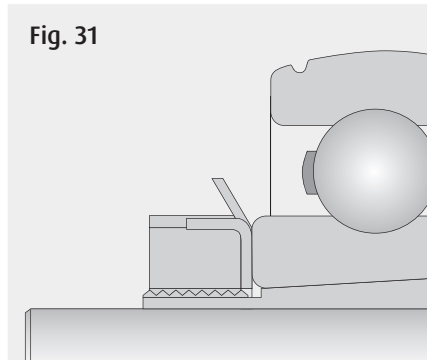

Fig. 31



Installing tapered adapter sleeve locking arrangements (Fig. 31)

PROCEDURE

1. Clean the shaft, sleeve and bearing bore of any oil or grease.
2. Install the mounted unit onto the equipment.
3. Install the mounting bolts and tighten to secure mounted unit to the equipment.
4. Position the shaft within the unit and tighten up the lockup by hand. If the sleeve assembly turns on the shaft, tap the sleeve into the bearing to obtain a positive grip.
5. Use the appropriate spanner wrench to tighten the lock nut to the recommended torque. (see **Table 10**)
6. Check that the bearing rotates freely to ensure that the internal clearance has not been completely removed.
7. Secure the nut with the appropriate locking tab. If no tab aligns with the locking slot in the nut, tighten the nut slightly until they align. Do not loosen the nut.



Table 9 - Set Screw Tightening Torques and Maximum Axial Loads

SET SCREW SIZE	SOCKET / ALLEN KEY SIZE	RECOMMENDED MAXIMUM TIGHTENING TORQUE		SET SCREW MAXIMUM AXIAL LOAD	
		newton metres (Nm)	lbf-inches	newtons (N)	lbf
1/4 UNF	1/8"	6.8	60	2,500	560
5/16 UNF	5/32"	12.4	110	3,500	785
3/8 UNF	3/16"	22.6	200	4,500	1,010
7/16 UNF	7/32"	31.6	280	7,500	1,685
1/2 UNF	1/4"	45.2	400	9,000	2,025
5/8 UNF	5/16"	53.9	477	15,000	3,370
M6 x 0.75	3 mm	5.7	50	2,500	560
M8 x 1.00	4 mm	12.4	110	3,500	785
M10 x 1.25	5 mm	27.1	240	5,000	1,235
M12 x 1.50	6 mm	38.4	340	8,000	1,800
M16 x 1.50	8 mm	53.9	477	15,000	3,370

Table 10 - Recommended Tightening Torques for Adapter Sleeve Units

SLEEVE BORE SIZE			TIGHTENING TORQUES	
mm	inch	inch	Nm	lbf-inches
20	3/4		30	265
25	15/16	1	40	355
30	1 1/8	1 3/16	50	440
35	1 1/4	1 3/8	60	530
40	1 7/16	1 1/2	65	575
45	1 11/16	1 3/4	75	660
50	1 15/16	2	85	750

It is advisable to the check tightness of the installation after 100 hours of operation.

METHODS OF DISMOUNTING

SELECTION OF DISMOUNTING METHODS

Bearings are typically removed for periodic inspection, lubrication, or for replacement. If the bearing being removed is going to be used again, it is crucial to remove the bearing the correct way using the proper procedure to avoid damaging the bearing. The removal process can be determined from the bearing size and the initial mounting arrangement.

There are four different types of mounting arrangements: cylindrical bore, tapered bore, adapter sleeve, and withdrawal sleeve. There are two basic removal methods, mechanical and thermal. Mechanical removal methods include pullers, presses and hydraulic nuts. Pullers are typically only used on small and medium sized bearings, while hydraulic removal methods are used on larger sized bearings or bearings with heavy press fits.

INTERFERENCE FITS - CYLINDRICAL SHAFTS

Bearings that have an inner diameter of up to 120 mm can be removed using a mechanical puller. In order to remove the bearing, the puller claws are clamped around the inner ring and a steady torque is then applied to the puller until the bearing is removed from the shaft. For bearing bores larger than 120 mm, it is recommended to use a hydraulic press to remove the bearing as the force required to remove the bearing is too great for that of a mechanical puller.

Table 11 - Methods of Bearing Dismounting

BEARING INNER RING SHAPE	SHAFT SHAPE AND FEATURES		MOUNTING PARTS AND FEATURES		WORKING METHOD
	Shape	Features	Parts	Features	
cylindrical bore	cylindrical	<ul style="list-style-type: none"> > shaft with shoulder > with or without oil duct 	<ul style="list-style-type: none"> > with or without spacer 	--	<ul style="list-style-type: none"> > bearing puller > press > oil injection pump + puller
tapered bore	tapered	<ul style="list-style-type: none"> > shaft with shoulder > with or without oil duct 	<ul style="list-style-type: none"> > with or without spacer 	--	<ul style="list-style-type: none"> > bearing puller > press > oil injection pump + puller
tapered bore	cylindrical	<ul style="list-style-type: none"> > shaft with shoulder 	<ul style="list-style-type: none"> > adapter sleeve > with or without spacer 	<ul style="list-style-type: none"> > with or without oil duct 	<ul style="list-style-type: none"> > dead-blow mallet > bearing puller > press > oil injection pump + puller
tapered bore	cylindrical	<ul style="list-style-type: none"> > shaft with shoulder 	<ul style="list-style-type: none"> > withdrawal sleeve 	<ul style="list-style-type: none"> > with or without oil duct 	<ul style="list-style-type: none"> > nut > hydraulic nut > oil injection pump + nut

INTERFERENCE FITS - SHAFT AND HOUSING

For small to medium sized bearings with interference fits in the housing, these can be removed by inserting a sleeve in the housing and hammering the sleeve uniformly until the bearing is free from the housing. Larger bearings require hydraulic presses in order to remove.

For bearings with an interference fit on both the shaft and the housing, it is recommended to push the shaft out of the bearing with the bearing fixed into the housing.

DISMOUNTING TAPERED BORE BEARINGS

In order to remove small to medium sized bearings with tapered bores, the puller should engage and pull against the inner ring, as the interference fit is on the shaft. Centering the bearing puller is important for tapered bore bearing removal in order to help eliminate the risk of permanent damage and to allow for an easier bearing removal. The use of a lock nut when removing bearings from tapered bores is recommended to prevent the bearing from flying off the shaft.

DISMOUNTING FROM SLEEVES

For bearings with adapter sleeves, the bearing can be removed by installing a fixture to the shaft that locks the inner ring in place and then loosening the nut several turns. Then, the sleeve is then hammered uniformly using a suitable tool until the bearing and sleeve are removed.

For withdrawal sleeves, the removal nut is tightened. This procedure is often difficult, and so it is also possible to drill and tap bolt holes in the nut and withdraw the sleeve by tightening the bolts. The benefit of removal sleeves is that, if installed properly, they cause no damage to the bearing or shaft when removed.

HYDRAULIC NUTS

Hydraulic nuts can considerably reduce time and effort in bearing removal when compared to their mechanical puller counterparts. This type of removal method is typically used to remove medium and large sized bearings with a bore diameter greater than 120 mm. When using hydraulic nuts, it is important to wear proper Personal Protective Equipment (PPE) such as safety glasses, gloves, and protective footwear.

CLEANING AND REUSE

In order to determine if the removed bearing can be used again, the bearing must first be cleaned. This cleaning removes the grease and any other debris or particulates that may have found their way into the grease. For the initial cleaning, wash the bearing using an industrial safety-solvent, or petroleum-based solvent such as kerosene. Once the bearing has been washed with the solvent, drain the solution and then flush with hot, light oil and drain once more. Then proceed with the visual examination of the bearing to determine if it can be used again.

If the bearing is being sent to NSK's America's Technical Center for analysis, apply a light coating of rust preventative oil on the bearing then package and store the bearing in a dry, cool environment until it is shipped. If the bearing was removed for relubrication with new grease or oil, the new lubricant may be added to the bearing following the hot, light oil wash.

CHECKING SHAFTS AND HOUSINGS

CHECKING OF CYLINDRICAL SHAFTS

Dimensional check of shaft

Measure the shaft size at the place where the bearing will be mounted to confirm that the bearing size is correct. The measurement positions are shown in Figure 32. Use an outside micrometer.

Inspect the shaft outside surface - where the bearing was mounted for scratches, dents, rust or stepped wearing.

- › **When there are scratches, dents or rust** - round the edges or remove with oil stone and/or sandpaper to smoothen the surface.
- › **When there is stepped wearing** - after measuring the shaft, decide whether correction is possible.

Anticorrosive agent - apply after completion of check.

CHECKING OF TAPERED SHAFTS

Check the shaft shape - where the bearing will be mounted to confirm that its shape is correct. The measurement positions are shown in Figure 33. Use a taper gauge (sine-bar system).

Inspect the shaft outside surface - where the bearing was mounted for scratches, dents, rust or stepped wearing.

- › **When there are scratches, dents or rust** - round the edges or remove with oil stone and/or sandpaper to smoothen the surface. If the area with rust to be corrected is wide, inspect the shape of the tapered zone by using a taper gauge. Apply a thin coat of bluing over the entire surface of the taper gauge bore face, insert it slowly after adjusting the taper gauge to the shaft center tapered shaft, and execute a run-in by moving back-and-forth. Pull the taper gauge out slowly when adjusting to the shaft center, observing where blue dye is attached to the surface of tapered shaft. If the blue area is larger than 80%, the shaft may be reused.
- › **When there is stepped wearing** - after measuring the shaft, decide whether correction is possible.

Anticorrosive agent - apply after completion of check.

Fig. 32 - Checking Cylindrical Shafts

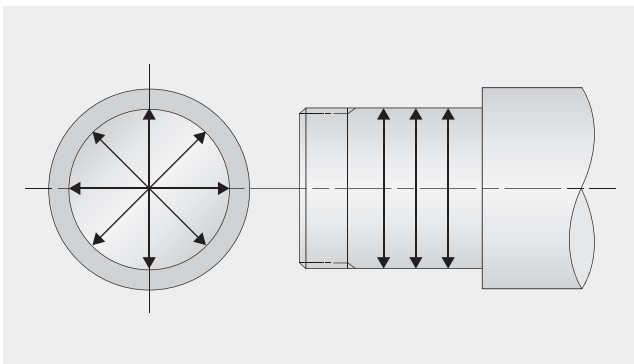
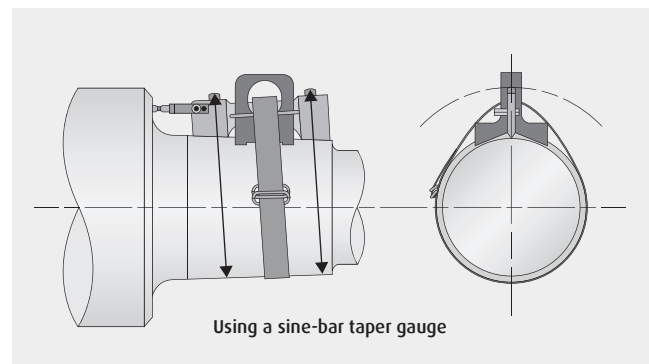

Fig. 33 - Checking Tapered Shafts



CHECKING OF HOUSING - INTEGRATED TYPE

Check the bore size of the housing - where the bearing will be mounted to confirm that the size is correct. The measurement position is shown in Figure 34.

Use an inside micrometer.

Inspect the housing bore face - where the bearing was mounted for scratches, dents, rust or stepped wearing.

- › **When there are scratches, dents or rust** - round the edges or remove with oil stone and/or sandpaper to smoothen the surface.
- › **When there is stepped wearing** - from the dimensional check, decide whether correction and reuse are possible. In this case, if the measured value of the housing bore is within its tolerance, remove the stepped worn part with oil stone and/or sandpaper, etc. and smoothen the surface, then, reuse. If the stepped wearing is severe, either plate or apply thermal spraying to reconstitute to the correct housing size before reusing.

Anticorrosive agent - apply after completion of check.

CHECKING OF HOUSING - SPLIT TYPE

Check the bore size of the assembled housing - where the bearing will be mounted to confirm that the dimension is correct. The measurement position is shown in Figure 35. Use an inside micrometer.

Use an inside micrometer.

Inspect the housing bore face - where the bearing was mounted for scratches, dents, rust or stepped wearing.

- › **When there are scratches, dents or rust** - round the edges or remove with oil stone and/or sandpaper to smoothen the surface.
- › **When there is stepped wearing** - from the dimensional check, decide whether correction is possible. If the measured value of housing bore is within its tolerance, remove the stepped worn portion with oil stone and/or sandpaper, smoothen the surface and reuse.
- › **When stepped wear is severe**, either plate or apply thermal spraying to reconstitute to the correct housing size and reuse.
- › **When there is a step at the joint** of the split housing halves, correction or a replacement housing is required.

Anticorrosive agent - apply after completion of check.

Fig. 34 - Checking Housings, Integrated Type

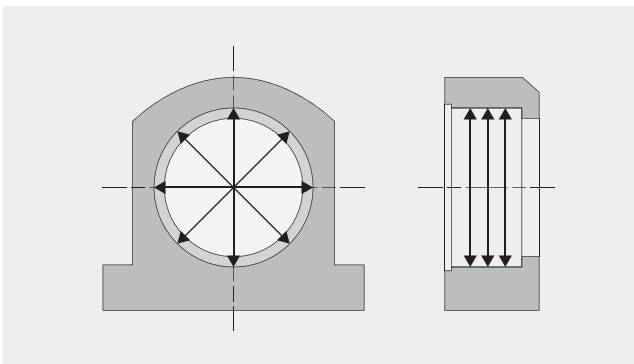
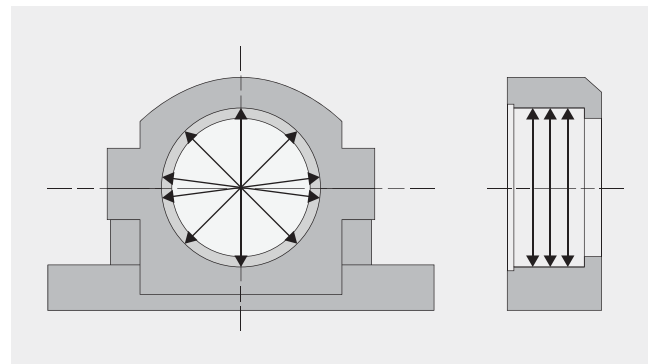

Fig. 35 - Checking Housings, Split Type



CHECKING SLEEVES AND LOCK NUTS

CHECKING ADAPTER AND WITHDRAWAL SLEEVES

After removal of the adapter or withdrawal sleeve, check the appearance as follows:

Inspect the sleeve threads - for crushed thread ridges or rust in thread valleys. If there is any indication of either, do not reuse.

Inspect the sleeve bore and outside surface - for scratches, dents, rust or uneven wearing.

- › **When there are scratches, dents or rust** - round the edges or remove with oil stone and/or sandpaper to smoothen the surface. If dents are severe, do not reuse.
- › **When uneven wear is found** - do not reuse.

Inspect the sleeve slot - for deformation or chips. If there is any indication of either, do not reuse.

Anticorrosive agent - apply after completion of check.

CHECKING LOCK NUTS

After removal of the lock nut, check the appearance as follows:

Inspect the lock nut threads - for crushed thread ridges or rust in thread valleys. If there is any indication of either, do not reuse.

Inspect the lock nut end face - for scratches, dents, rust or uneven wearing.

- › **When there are scratches, dents or rust** - round the edges or remove with oil stone and/or sandpaper to smoothen the surface. If dents or rust are severe, do not reuse.
- › **When uneven wear is found** - do not reuse.

Inspect the lock nut slots for deformation. If found, do not reuse.

Anticorrosive agent - apply after completion of check.

CHECKING LOCK WASHER OR LOCK PLATE

After removal of the lock washer or lock plate, check the appearance for chips or severe deformation. If there is any indication of either, do not reuse.

In general, when a bearing is handled correctly it can be used for the duration of its fatigue life. Occasionally it may fail prematurely as a result of bearing damage. Such premature damage is often caused by inadequate consideration given to the fundamentals of mounting, handling, and lubrication, or inadequate compensation for contamination or thermal influences of the shaft and/or housing.

If a bearing is found to be damaged when dismounted, the cause should be thoroughly investigated. It may be difficult to determine the real cause of the trouble merely by the appearance of the damaged bearing, as several of the factors mentioned above may be working together to contribute to the damage.

Periodic maintenance and inspection reports should be reviewed for any indications of phenomena observed during operation. The condition of residual lubricant in the bearing should be carefully examined. The results of shaft, housing and sleeve inspections should be reviewed for possible associated cause of effect.

The potential for preventing reoccurrence increases dramatically with acquiring a complete understanding of the machinery, the operating conditions, the structure surrounding the bearing, and any warning signs before and after the trouble occurred.

Refer to **Section E: Troubleshooting / Bearing Damage** of this catalog for additional information. For assistance with diagnosing bearing damage and failure, and implementing effective solutions, contact NSK.



SECTION C:

SHAFT AND HOUSING FITS

GENERAL INFORMATION	C3
IMPORTANCE OF PROPER FITS	C4
LOAD CONDITIONS	C5
FIT CALCULATION	C6
RECOMMENDED SHAFT FITS	C7
Shaft Tolerances for Radial Bearings	C7
Shaft Tolerances for Inch Size Tapered Roller Bearings.....	C8
Shaft Tolerances for Bearings Mounted on Sleeves.....	C8
RECOMMENDED HOUSING FITS	C9
Housing Tolerances for Radial Bearings	C9
Housing Tolerances for Inch Size Tapered Roller Bearings.....	C10
FITS AND CLEARANCE	C11
Fitting and Residual Clearance	C11
Temperature Effects on Internal Clearance	C11
Effective Clearance	C11
MAGNITUDE OF LOAD AND INTERFERENCE	C12
INTERFERENCE VARIATION DUE TO TEMPERATURE	C12
FINISH OF SHAFT AND HOUSING	C13
ACCURACY AND SURFACE FINISH OF SHAFTS AND HOUSINGS	C13
FITS FOR HOLLOW SHAFTS	C15
TABLES	C17
Tolerances for Shaft Diameters	C17
Tolerances for Housing Diameters	C21
Shaft Bearing-Seat Diameters	C25
Housing Bearing-Seat Diameters	C39
Tolerance Grades IT	C51

SHAFT AND HOUSING FITS

For rolling bearings to achieve their full life expectancy, their inner and outer rings must be properly fitted to the shaft and the housing. Typically for the ring that rotates an interference fit is chosen, whereas the stationary ring will have a clearance or loose fit. The shaft and housing tolerances are selected by considering many factors: the magnitude of load, the temperature differences among the bearing, shaft and housing, the level of surface finishes, the shaft thickness, and the mounting / dismounting methods.

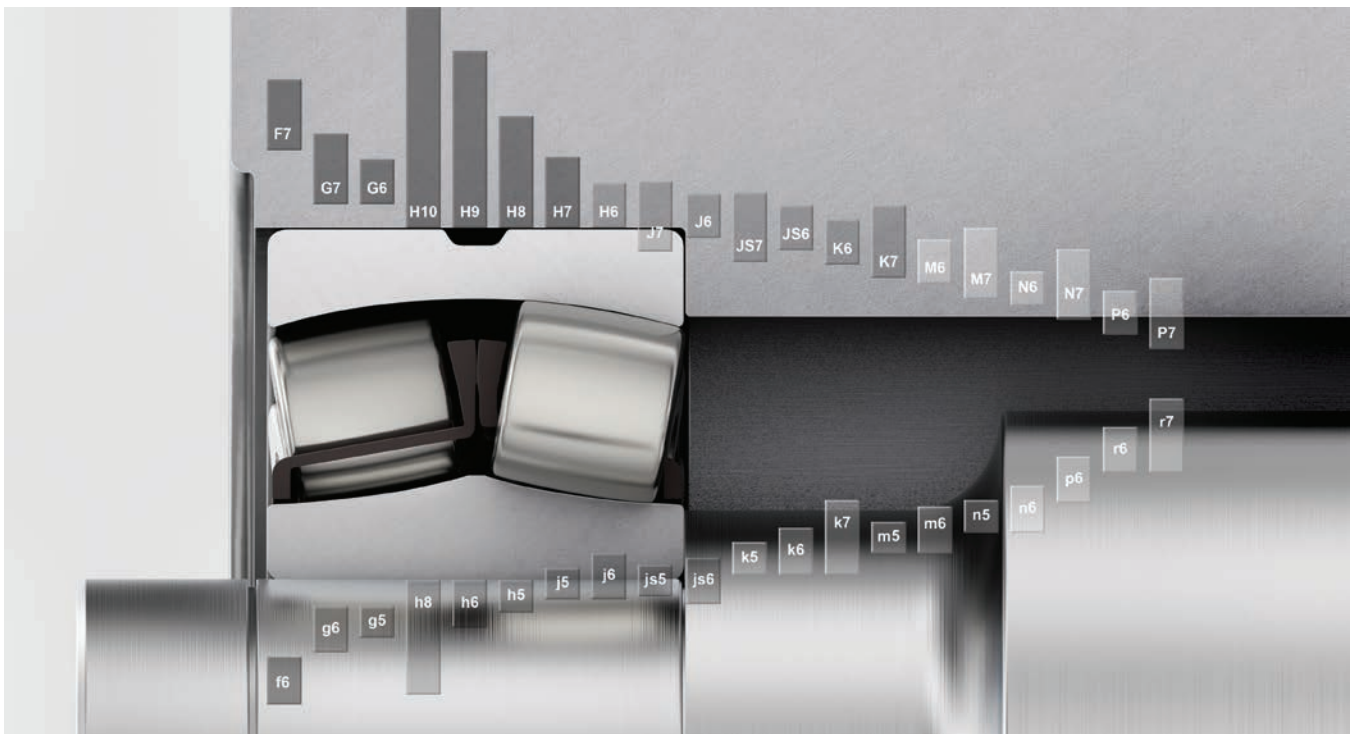

The image above is a liberal depiction of shaft and housing fits ranging from loose to tight. Recommended shaft and housing fits by bearing type and application, as well as calculated fit values, can be found throughout this section.

IMPORTANCE OF PROPER FITS

When properly mounting a rolling element bearing, there must be adequate interference to prevent harmful damage to the mating surfaces. Creep or fretting damage can occur without sufficient interference fits. This damage can cause debris from the mating surfaces to enter the interior of the bearing, causing denting, vibration, and shortened bearing life.

In order to mitigate the risk of creep it is important to have sufficient interference between components to firmly secure the rotating bearing ring to its mating component - inner ring to shaft, outer ring to housing. Snap rings and lock nuts are used to secure the bearing axially, but they will have little effect in preventing creep.

Fits without interference can be used in certain operating conditions or for ease of mounting or dismounting.

Anti-fretting paste is suggested for loose fits.

LOAD CONDITIONS AND FITS

LOAD CONDITIONS

Bearing loads are typically classified by the magnitude of the load and the direction of the load. With respect to magnitude, loads are classified as light, medium, or heavy. With respect to direction, they are classified as rotating, stationary, or indeterminate. The direction of the load does not apply to the bearing itself; rather it is intended to describe the means by which the load is acting on each of the bearing rings.

Whether an interference fit or a loose fit should be adopted depends entirely upon whether the load applied to the inner and outer rings is rotating or stationary. A “rotating load” is one where the loading direction on a bearing ring changes continuously regardless of whether the bearing ring itself rotates or remains stationary. On the other hand, a “stationary load” is one where the loading direction on a bearing ring is the same regardless of whether the bearing ring itself rotates or remains stationary. An “indeterminate load” is one that is impacted by unbalanced weight, vibration or shock, etc. that impacts the direction of the load in ways that cannot be easily predicted.

As an example, when the load direction on a bearing remains constant and the inner ring rotates and the outer ring stays fixed, a rotating load is applied to the inner ring and a stationary load to the outer ring. In the case that the majority of the bearing load is an unbalanced load due to rotation, even if the inner ring rotates and the outer ring stays fixed, a stationary load is applied to the inner ring and a rotating load to the outer ring (see Table 1).

Depending on the actual conditions, the situation is not usually as simple as described above. The loads may vary in complex ways with the load direction being a combination of fixed and rotating loads caused by mass, by imbalance, by vibration, and by power transmission. If the load direction on a bearing is highly irregular or a rotating load and stationary load are applied alternatively, such a load is called an indeterminate load.

Table 1 - Rotating and Stationary Load of Inner Rings



Rotating load on inner ring	Bearing load direction is constant, the inner ring rotates and the outer ring remains fixed
	Inner ring remains fixed, the outer ring rotates, and the load direction rotates with the same speed as the outer ring (unbalanced load, etc.)
Stationary load on inner ring	Outer ring remains fixed, the inner ring rotates, and the load direction rotates with the same speed as the inner ring (unbalanced load, etc.).
	Bearing load direction is constant, the outer ring rotates, and the inner ring remains fixed.

The fit of a bearing ring on which a rotating load is applied should generally be an interference fit. If a bearing ring, on which a rotating load is applied, is mounted with a loose fit, the bearing ring may slip on the shaft or in the housing and, if the load is heavy, the fitting surface may be damaged or fretting corrosion may occur. The tightness of the fit should be sufficient to prevent the interference from becoming zero as a result of the applied load and a temperature difference between the inner ring and shaft or between the outer ring and housing during operation.

For large bearings, to avoid the difficulty of mounting and dismounting, sometimes a loose fit is adopted for the bearing ring on which a rotating load is applied. In such a case, the shaft material must be sufficiently hard, its surface must be well finished, and a lubricant needs to be applied to minimize damage due to slipping.

There is generally no problem with slipping between the shaft or housing for a bearing ring on which a stationary load is applied; therefore, a loose fit or transition fit can be used. The looseness of the fit depends on the accuracy required in use, temperature variations and the reduction in the load distribution range caused by bearing-ring deformation.

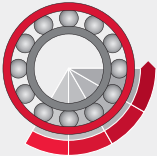
Table 2 - Load Conditions and Fits

OPERATING CONDITIONS		LOAD CONDITION	RECOMMENDED FITS	
			Inner Ring	Outer Ring
Inner ring : rotating Outer ring : stationary Load : stationary		Rotating inner ring load Stationary outer ring load	Tight fit	Loose fit
Inner ring : stationary Outer ring : rotating Load : rotating		Rotating inner ring load Stationary outer ring load	Tight fit	Loose fit
Inner ring : stationary Outer ring : rotating Load : stationary		Stationary inner ring load Rotating outer ring load	Loose fit	Tight fit
Inner ring : rotating Outer ring : stationary Load : rotating		Stationary inner ring load Rotating outer ring load	Loose fit	Tight fit

FIT CALCULATION

It is easier to mount a bearing with a loose fit than with an interference fit. However, if there is clearance between the fitting surfaces or too little interference, depending on the loading condition, creep may occur and damage the fitting surfaces; therefore, a sufficient interference must be chosen to prevent such damage.

The most common loading condition is to have a fixed load and fixed direction with the inner ring (i.e. shaft) rotating and the outer ring stationary. This condition is referred to as a rotating load on the inner ring or a stationary load on the outer ring. In other words, a circumferential load is applied to the inner ring and a spot load on the outer ring.

For indeterminate loads caused by unbalanced weight, vibration, etc., interference fits are usually recommended for both inner and outer bearing rings. Standard shaft and housing fit tolerances are typically sufficient. However, if axial movement of the outer ring is desired, a looser than standard fit may be appropriate.

The selection of proper fits according to load conditions are presented in **Table 2**. For recommended shaft and housing fits by bearing type in accordance to load conditions and operating conditions, see **Tables 3 to 7**.

RECOMMENDED SHAFT FITS

Table 3 - Shaft Tolerances for Radial Bearings

LOAD CONDITIONS		EXAMPLES	SHAFT DIAMETER (MM)			TOLERANCE OF SHAFT	REMARKS	
			Ball bearings	Cylindrical roller tapered roller bearings	Spherical roller bearings			
Radial bearings with cylindrical bores								
Rotating outer ring load	Easy axial displacement of inner ring on shaft desirable	Wheels on stationary axles	All shaft diameters			g6	Use g5 and h5 where accuracy is required. In case of large bearings, f6 can be used to allow easy axial movement	
	Easy axial displacement of inner ring on shaft unnecessary	Tension pulleys rope sheaves				h6		
Rotating inner ring load or direction of load indeterminate	Light loads or variable Loads ($\leq 0.06 Cr (1)$)	Electrical home appliances, pumps, blowers, transport vehicles, precision machinery, machine tools	≤ 18	-	-	js5	-	
			18-100	≤ 40	-	js6 (j6)		
			100-200	40-140	-	k6		
			-	140-200	-	m6		
	Normal loads (0.06 to 0.13 Cr (1))	General bearing applications, medium and large motors, turbines, pumps, engine main bearings, gears, woodworking machine	≤ 18	-	-	js5/6 (j5/6)		k6 and m6 can be used for single-row tapered roller bearings and single-row angular contact ball bearings instead of k5 and m5
			18-100	≤ 40	≤ 40	k5/6		
			100-140	40-100	40-65	m5/6		
			140-200	100-140	65-100	m6		
			200-280	140-200	100-140	n6		
			-	200-400	140-280	p6		
	Heavy loads or shock loads ($> 0.13 Cr (1)$)	Railway axleboxes, industrial vehicles, traction motors, construction, equipment, crushers	-	-	280-500	r6		More than CN bearing internal clearance is necessary
			-	-	> 500	r7		
			-	50-140	50-100	n6		
			-	140-200	100-140	p6		
Axial Loads Only			All Shaft Diameters			js6 (j6)	-	
Radial bearings with tapered bores and sleeves								
All types of loading		General bearing applications, railway axleboxes	All shaft diameters			h9/IT5	IT5 and IT7 mean that the deviation of the shaft from its true geometric form, e.g. roundness and cylindricity should be within the tolerances of IT5 h10/IT7 and IT7 respectively	
		Transmission shafts, woodworking spindles				h10/IT7		
Thrust bearings with shafts								
Central axial load only		Main shafts of lathes	All shaft diameters			h6 or js6 (j6)	-	
Combined radial and axial loads (Spherical thrust roller bearings)	Stationary inner ring load	Cone crushers	All shaft diameters			js6 (j6)		
	Rotating inner ring load or direction of load indeterminate	Paper pulp refiners, plastic extruders	≤ 200			k6		
			200 - 400			m6		
			> 400			n6		

Notes : This table is applicable only to solid steel shafts.
 (1) Cr represents the basic load rating of the bearing.

Table 4 - Shaft Tolerances for Inch Size Tapered Roller Bearings

OPERATING CONDITIONS		NOMINAL BORE DIAMETER (INCH)		BORE DIAMETER TOLERANCE (INCH)		SHAFT DIAMETER TOLERANCE (INCH)		RESULTING FIT (0.0001")	REMARKS
		over	incl	max	min	max	min		
Rotating Inner Ring Loads	Normal loads	-	3	+0.0005	0.0000	+0.0015	+0.0010	5 T / 15 T	For bearings with d≤6", clearance is usually larger than CN.
		3	12	+0.0010	0.0000	+0.0025	+0.0015	5 T / 25 T	
		12	24	+0.0020	0.0000	+0.0050	+0.0030	10 T / 50 T	
		24	36	+0.0030	0.0000	+0.0075	+0.0045	15 T / 75 T	
	Heavy Loads Shock Loads High Speeds	-	3	+0.0005	0.0000	+0.0025	+0.0015	10 T / 25 T	In general, bearings with a clearance larger than CN are used. "--" means that the average interference is about 0.0005 d.
		3	12	+0.0010	0.0000	--	--	--	
12		24	+0.0020	0.0000	--	--	--		
Stationary Inner Ring Loads	Normal Loads Without Shocks	-	3	+0.0005	0.0000	+0.0005	0.0000	5 L / 5 T	The inner ring cannot be displaced axially. When heavy or shock loads exist, the values for rotating inner ring loads - heavy or shock loads - apply.
		3	12	+0.0010	0.0000	+0.0010	0.0000	10 L / 10 T	
		12	24	+0.0020	0.0000	+0.0020	0.0000	20 L / 20 T	
		24	36	+0.0030	0.0000	+0.0030	0.0000	30 L / 30 T	
		-	3	+0.0005	0.0000	0.0000	-0.0005	10 L / 0	The inner ring can be displaced axially.
		3	12	+0.0010	0.0000	0.0000	-0.0010	20 L / 0	
		12	24	+0.0020	0.0000	0.0000	-0.0020	40 L / 0	
		24	36	+0.0030	0.0000	0.0000	-0.0030	60 L / 0	

Table 5 - Shaft Tolerances for Bearings Mounted on Sleeves

NOMINAL SHAFT DIAMETER (MM)		DIAMETER AND FORM TOLERANCES (INCH)					
		h9		IT5/2	h10		IT7/2
over	incl.	high	low	max	high	low	max
10	18	0.0000	-0.0017	0.0002	0.0000	-0.0028	0.0004
18	30	0.0000	-0.0020	0.0002	0.0000	-0.0033	0.0004
30	50	0.0000	-0.0024	0.0002	0.0000	-0.0039	0.0005
50	80	0.0000	-0.0029	0.0003	0.0000	-0.0047	0.0006
80	120	0.0000	-0.0034	0.0003	0.0000	-0.0055	0.0007
120	180	0.0000	-0.0039	0.0004	0.0000	-0.0063	0.0008
180	250	0.0000	-0.0045	0.0004	0.0000	-0.0073	0.0009
250	315	0.0000	-0.0051	0.0005	0.0000	-0.0083	0.0010
315	400	0.0000	-0.0055	0.0005	0.0000	-0.0091	0.0011
400	500	0.0000	-0.0061	0.0005	0.0000	-0.0098	0.0012
500	630	0.0000	-0.0069	0.0006	0.0000	-0.0110	0.0014
630	800	0.0000	-0.0079	0.0007	0.0000	-0.0126	0.0016
800	1000	0.0000	-0.0091	0.0008	0.0000	-0.0142	0.0018
1000	1250	0.0000	-0.0102	0.0009	0.0000	-0.0165	0.0021

RECOMMENDED HOUSING FITS

Table 6 - Housing Tolerances for Radial Bearings

LOAD CONDITIONS			EXAMPLES	TOLERANCES FOR HOUSING BORES	AXIAL DISPLACEMENT OF OUTER RING	REMARKS
Radial bearings with housings						
Solid housings	Rotating outer ring load	Heavy loads on bearing in thin-walled housing of heavy shock loads	Automotive wheel hubs (Roller bearings) Crane traveling wheels	P7	Impossible	-
		Normal or heavy loads	Automotive wheel hubs (Ball bearings) Vibrating screens	N7		
		Light or variable loads	Conveyor rollers rope sheaves Tension pulleys	M7		
Solid or split housings	Direction of load indeterminate	Heavy shock loads	Traction motors	K7	Impossible	Axial displacement of the outer ring is not required
		Normal or heavy loads	Pumps crankshaft Main bearings			
		Normal or light loads	Medium and large motors			
Solid housing	Rotating inner ring load	Loads of all kinds	General bearing applications, Railway axleboxes	H7	Easily possible	-
		Normal or light loads	Plummer blocks	H8		
		High temperature rise of inner ring through shaft	Paper dryers	G7		
Solid housing	Direction of load indeterminate	Accurate running required under normal or light loads	Grinding spindle rear ball bearings	JS6 (J6)	Possible	For heavy loads, interference fit tighter than K is used. When high accuracy is required, very strict tolerances should be used for fitting
			High speed centrifugal compressor free bearings			
	Rotating inner ring load	Accurate running and high rigidity required under variable loads	Grinding spindle front ball bearings	K6	Impossible	
			High speed centrifugal compressor fixed bearings			
Rotating inner ring load	Minimum noise is required	Cylindrical roller bearings for machine tool main spindle	M6 or N6	Fixed		
		Electrical home appliances	H6	Easily possible	-	
Thrust bearings with housings						
Axial load only			Thrust ball bearings	Clearance > 0.25 mm		For general applications
				H8		When precision is required
				Spherical thrust roller bearings Steep angle tapered roller bearings	Outer ring has radial clearance	
Combined radial and axial loads	Stationary outer ring loads		Spherical thrust roller bearings	H7 or JS7 (J7)		-
				K7		Normal loads
	Rotating outer ring loads or direction of load indeterminate			M7		Relatively heavy radial loads

Notes: (1) This table is applicable to cast iron and steel housings. For housings made of light alloys, the interference should be tighter than those in this table.
 (2) Refer to NSK catalogs for special fittings such as drawn cup needle.

Table 7 - Housing Tolerances for Inch Size Tapered Roller Bearings

OPERATING CONDITIONS		NOMINAL OUTER DIAMETER (INCH)		OUTSIDE DIAMETER TOLERANCE (INCH)		HOUSING BORE TOLERANCE (INCH)		RESULTING FIT (0.0001")	REMARKS
		over	incl	max	min	max	min		
Stationary Outer Ring Loads	Used either on free-end or fixed-end	-	3	+0.0010	0.0000	+0.0030	+0.0020	30 L / 10 L	The outer ring can be easily displaced axially
		3	6	+0.0010	0.0000	+0.0030	+0.0020	30 L / 10 L	
		6	12	+0.0010	0.0000	+0.0030	+0.0020	30 L / 10 L	
		12	24	+0.0020	0.0000	+0.0060	+0.0040	60 L / 20 L	
		24	36	+0.0030	0.0000	+0.0090	+0.0060	90 L / 30 L	
	The outer ring position can be adjusted axially	-	3	+0.0010	0.0000	+0.0010	0.0000	10 L / 10 T	The outer ring can be displaced axially
		3	6	+0.0010	0.0000	+0.0010	0.0000	10 L / 10 T	
		6	12	+0.0010	0.0000	+0.0020	0.0000	20 L / 10 T	
		12	24	+0.0020	0.0000	+0.0030	0.0010	30 L / 10 T	
		24	36	+0.0030	0.0000	+0.0050	+0.0020	50 L / 10 T	
	The outer ring position cannot be adjusted axially	-	3	+0.0010	0.0000	-0.0005	-0.0015	5 T / 25 T	Generally, the outer ring is fixed axially
		3	6	+0.0010	0.0000	-0.0010	-0.0020	10 T / 30 T	
		6	12	+0.0010	0.0000	-0.0010	-0.0020	10 T / 30 T	
		12	24	+0.0020	0.0000	-0.0010	-0.0030	10 T / 50 T	
24		36	+0.0030	0.0000	-0.0010	-0.0040	10 T / 70 T		
Rotating Outer Ring Loads	Normal Loads The outer ring position cannot be adjusted axially	-	3	+0.0010	0.0000	-0.0005	-0.0015	5 T / 25 T	The outer ring is fixed axially
		3	6	+0.0010	0.0000	-0.0010	-0.0020	10 T / 30 T	
		6	12	+0.0010	0.0000	-0.0010	-0.0020	10 T / 30 T	
		12	24	+0.0020	0.0000	-0.0010	-0.0030	10 T / 50 T	
		24	36	+0.0030	0.0000	-0.0010	-0.0040	10 T / 70 T	

FITS AND CLEARANCE

FITTING AND RESIDUAL CLEARANCE

The internal clearance in rolling bearings in operation greatly influences bearing performance including fatigue life, vibration, noise, heat-generation, etc. Consequently, the selection of the proper internal clearance is one of the most important tasks when choosing a bearing after the type and size have been determined.

When the inner ring or the outer ring is tight-fitted on a shaft or in a housing, a decrease in the radial internal clearance is caused by the expansion or contraction of the bearing rings. The decrease varies according to the bearing type and size and design of the shaft and housing. The amount of this decrease is approximately 70 to 90% of the interference. The internal clearance after subtracting this decrease from the theoretical internal clearance (Δ_0) is called the residual clearance (Δ_f).

Fig. 1 - Fitting and Clearance Reduction

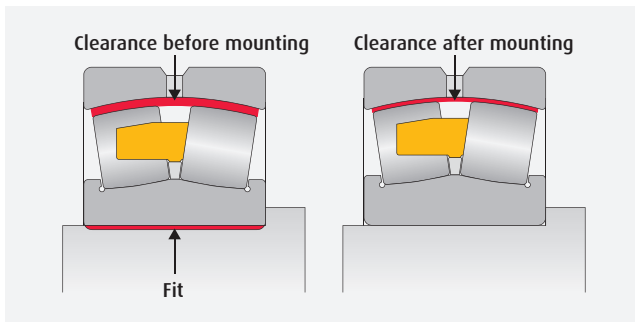

TEMPERATURE EFFECTS ON INTERNAL CLEARANCE

Under normal operation, the radial internal clearance of a bearing will decrease because of the temperature differences between the inner and outer rings. Typically, the temperatures of the inner ring and the rolling elements are higher than that of the outer ring by 5 to 10°C. When the shaft is heated or when the housing is cooled, the difference between the inner and outer rings is even larger.

The amount of decrease due to thermal expansion can be calculated from the following equations:

$$\delta t = \alpha \Delta t D_e$$

Where:

- δt Internal clearance decrease (mm) due to temperature
- α Coefficient of linear expansion of bearing steel
(12.5×10^{-6}) ($1/^\circ\text{C}$)
- Δt Temperature difference between inner & outer rings
($^\circ\text{C}$)
- D_e Outer ring raceway diameter (mm)

For ball bearings:

$$D_e \approx 1 / 5 (4D + d)$$

For roller bearings:

$$D_e \approx 1 / 4 (3D + d)$$

Where:

- D Bearing outside diameter (mm)
- d Bearing bore diameter (mm)

EFFECTIVE CLEARANCE

The effective, or operating, clearance Δ is obtained by subtracting δt from the internal clearance after mounting Δ_f . Theoretically, the longest life of a bearing can be expected when the effective clearance is slightly negative. However, it is difficult to achieve this condition and excessive negative clearance will shorten bearing life. Therefore, a clearance of zero or a slightly positive value is preferable.

Fig. 2 - Changes in Radial Clearance of Bearings

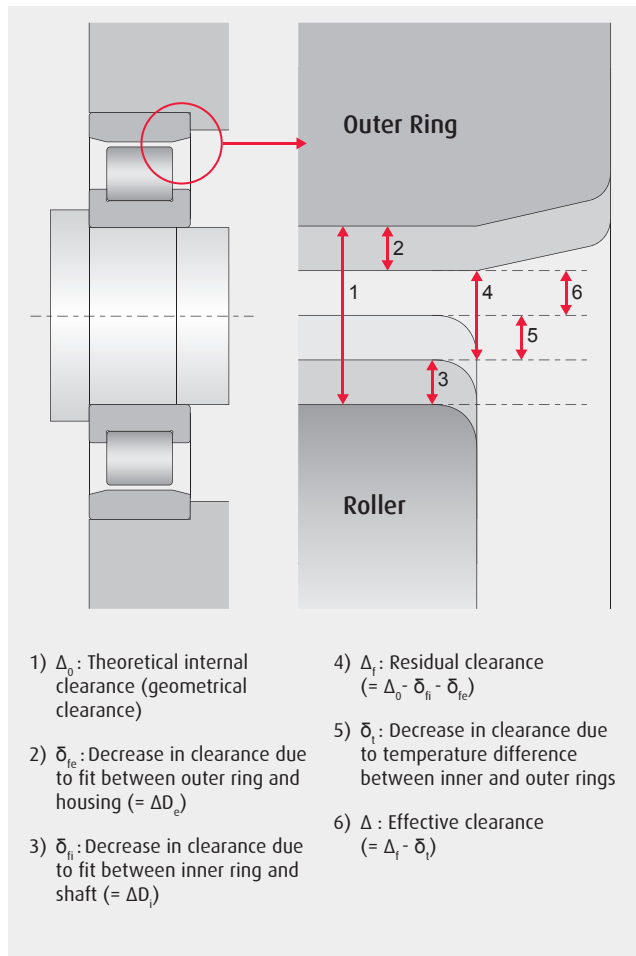

Angular contact ball bearings or tapered roller bearings normally require the user to set the internal clearance at mounting. The user should check the proper orientation of these bearings by checking the original bearings or the service manual for the machine. A check should also be made for the recommended set clearance. This can be obtained from the service manual, the machine manufacturer, or in consultation with the bearing manufacturer.

MAGNITUDE OF LOAD AND INTERFERENCE

Under load, a slight amount of deflection or deformation of the bearing rings will occur. This reduces the interference fit. For this reason, heavier loaded bearings require a heavier initial interference fit. The required interference can be calculated using the following equations:

$$\Delta d_f = 0.08 \sqrt{\frac{d}{B}} F_r \times 10^{-3} \quad \text{for light to normal loads}$$

$$\Delta d_e \geq 0.02 \frac{F_e}{B} \times 10^{-3} \quad \text{when } Fe > .20 \text{ Cor}$$

Where:

- Δd_f Interference decrease of inner ring (mm)
- Δd_e Effective interference (mm)
- d Bearing bore diameter (mm)
- B Inner ring width (mm)
- F_r Radial load applied to bearing (N)
- F_e Equivalent load (N)

INTERFERENCE VARIATION DUE TO TEMPERATURE

Interference can decrease when bearing temperature increases during operation. If the temperature difference between the interior of the bearing and the surrounding parts of the housing is $\Delta T(^{\circ}\text{C})$, then the temperature difference between the fitted surfaces of the shaft and the inner ring is estimated to be about $(0.1 \text{ to } 0.15)T$. Decrease of inner ring interference due to this difference may be calculated from the following equation:

$$\Delta dT = (0.10 \sim 0.15) \Delta T \cdot \alpha \cdot d = 0.0015 \Delta T \cdot d \times 10^{-3}$$

Where:

- ΔdT Decrease of interference of inner ring due to temperature increase (mm)
- ΔT Temperature difference between bearing and surrounding parts
- α Coefficient of linear expansion of bearing steel ($12.5 \times 10^{-6}(1/^{\circ}\text{C})$)
- d Bore diameter

SHAFTS AND HOUSINGS

FINISH OF SHAFT AND HOUSING

Since the roughness of fitted surfaces is reduced during fitting, the effective interference becomes less than the apparent interference. The amount of this interference decrease varies depending on the roughness of the surfaces and may be estimated using the following equations:

For ground shafts:

$$\Delta d = d / (d+2) \Delta da$$

For machined shafts:

$$\Delta d = d / (d+3) \Delta da$$

Where:

Δd Effective interference (mm)

Δda Apparent interference (mm)

d Bearing bore diameter (mm)

According to these equations, the effective interference of bearings with a bore diameter of 30 to 150 mm is about 95% of the apparent interference.

ACCURACY OF SHAFTS & HOUSINGS

If the accuracy of a shaft or housing does not meet specification, the performance of the bearings will be impacted. For example, inaccuracy in the squareness of the shaft shoulder may cause misalignment of bearing inner and outer rings, which may reduce bearing fatigue life by adding an edge load to the normal load. Cage fracture and seizure can occur for this same reason. Housings should be rigid in order to provide firm bearing support, as well as advantages with noise and load distribution.

For normal operating conditions, a turned finish or smooth bored finish is sufficient for the fitting surface; however, a ground finish is necessary for applications where vibration and noise must be low or where heavy loads are applied.

Where two or more bearings are mounted in a single solid housing, the fitting surfaces of the housing bore should be designed so both bearing seats may be finished together with one operation such as in-line boring. For split housings, care must be taken in the fabrication of the housing so the outer ring will not become deformed during installation. The accuracy and surface finish of shafts and housings are listed in **Table 8** for normal operating conditions. For IT tolerance grade values, please refer to **Table 14** on **page C51**.

Table 8 - Accuracy and Roughness of Shaft and Housing

ITEM	CLASS OF BEARINGS		SHAFT	HOUSING BORE
Tolerance for Out-of-Roundness	Normal	Class 6	IT3 / 2 to IT4 / 2	IT4 / 2 to IT5 / 2
	Class 5	Class 4	IT2 / 2 to IT3 / 2	IT2 / 2 to IT3 / 2
Tolerance for Cylindricity	Normal	Class 6	IT3 / 2 to IT4 / 2	IT4 / 2 to IT5 / 2
	Class 5	Class 4	IT2 / 2 to IT3 / 2	IT2 / 2 to IT3 / 2
Tolerance for Shoulder Runout	Normal	Class 6	IT3	IT3 to IT4
	Class 5	Class 4	IT3	IT3
Roughness of Fitting Surfaces R_a	Small Bearings: OD \leq 180 mm		32 μ in	63 μ in
	Large Bearings: OD $>$ 180 mm		63 μ in	125 μ in

Note: This table is for general recommendation using radius measuring method, the basic tolerance (IT) class should be selected in accordance with the bearing precision class. In cases where outer ring is mounted in the housing bore with interference, the accuracy of the shaft and housing should be higher since this affects the bearing raceway directly.

For a practical measurement of the out-of-roundness of shafts and housings:

- › Using an appropriate micrometer, measure the diameter in a single plane in four or more locations as equally spaced as possible angularly and record all dimensions
- › The out-of-roundness value is the difference between the maximum and minimum values obtained, Max (-) Min

The values derived from **Table 8** should be doubled since the diameter method has been used. The process can be repeated at different radial planes across the bearing seating location (see **Figure 3**).

An example of methodology to record and evaluate findings can be found in **Table 9**.

For a practical measurement of the cylindricity of shafts and housings:

- › Using an appropriate micrometer, measure the diameter at the same angular position in three or more axial planes equally spaced and covering the seating position of the bearing, recording all dimensions
- › The cylindricity value is the difference between the maximum and minimum values obtained, Max (-) Min

The values derived from **Table 8** should be doubled since the diameter method has been used. The process can be repeated at different angular positions across the bearing seating location (see **Figure 4**).

Fig. 3 - Checking Cylindrical Shafts

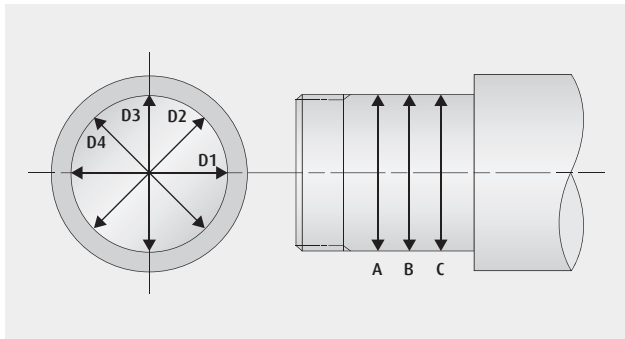

Fig. 4 - Checking Housings

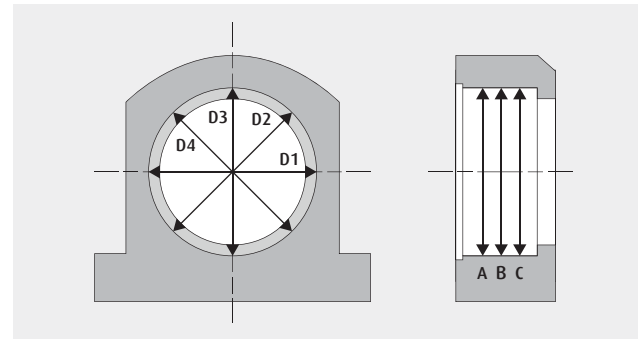

Table 9 - Recording and Evaluating Out-of-Roundness and Cylindricity

ANGULAR LOCATION	PLANE A	PLANE B	PLANE C	CYLINDRICITY
0°	D1 _A	D1 _B	D1 _C	Max (-) Min at 0°
45°	D2 _A	D2 _B	D2 _C	Max (-) Min at 45°
90°	D3 _A	D3 _B	D3 _C	Max (-) Min at 90°
135°	D4 _A	D4 _B	D4 _C	Max (-) Min at 135°
OUT-OF-ROUNDNESS	Max (-) Min Plane A	Max (-) Min Plane B	Max (-) Min Plane C	

Note: None of the individual values should exceed the tolerances in Table 8. In the case of split housings, additional angular positions of measurement are recommended.

SHAFTS AND HOUSINGS

FITS FOR HOLLOW SHAFTS

Hollow shafts can be compressed under the stress imparted by interference fits. This deflection in the shaft material may result in a loss of interference, exposing the interface to bearing creep when under load. Following is an approach for correcting shaft fits to make up for the deflection that may occur when using a hollow shaft.

$$\frac{\Delta d_h}{\Delta d_s} = \frac{M + 2 \left[\frac{k_o^2}{E_s(1-k_o^2)} + \frac{1}{E_i(1-k^2)} \right]}{M + \frac{2}{E_i(1-k^2)}}$$

Where:

- Δd_h Interference of fit, hollow shaft
- Δd_s Interference of fit, solid shaft
- d Shaft diameter, inner ring bore
- d_o Bore diameter, hollow shaft
- D_i Raceway diameter, inner ring
- E_i Young's Modulus, inner ring (MPa)
- E_s Young's Modulus, shaft (MPa)
- m_i Poisson's Number, inner ring
(inverse of Poisson's Ratio)
- m_s Poisson's Number, shaft
(inverse of Poisson's Ratio)
- $k = d/D_i$ Diameter ratio, bearing inner ring
- $k_o = d_o/d$ Diameter ratio, hollow shaft

$$M = \left[\frac{m_s - 1}{m_s E_s} - \frac{m_i - 1}{m_i E_i} \right]$$

Fig. 5 - Shaft Fit Compensation for Hollow Shafts

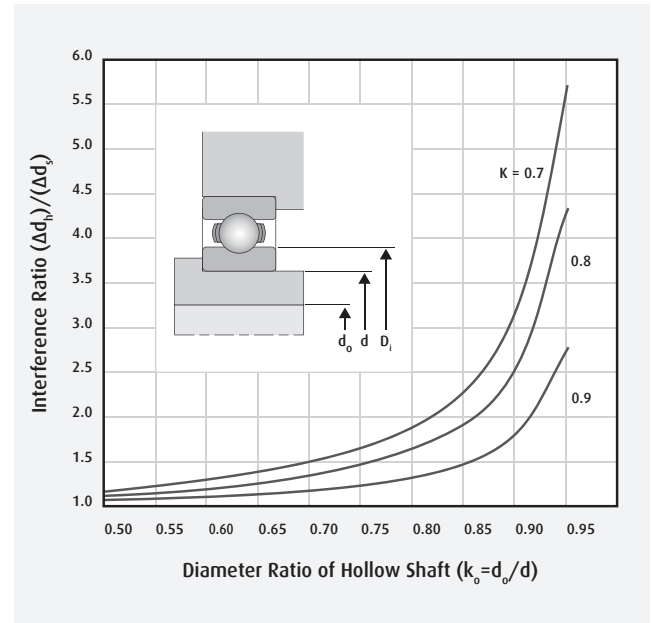

If D_i is not known for a particular bearing, it can be approximated by the following:

For ball bearings:

$$D_i \approx d + 0.2(D - d)$$

For roller bearings:

$$D_i \approx d + 0.25(D - d)$$

TOLERANCES FOR SHAFT DIAMETERS

Table 10 - Tolerances for Shaft Diameters

Units: inch

DIAMETER CLASS. (MM)		SINGLE PLANE MEAN B.D. DEVIATION (NORMAL)	f6	f7	g5	g6	h5	h6
over	incl	Δ dmp						
3	6	0 - 0.0003	- 0.0004 - 0.0007	- 0.0004 - 0.0009	- 0.0002 - 0.0004	- 0.0002 - 0.0005	0 - 0.0002	0 - 0.0003
6	10	0 - 0.0003	- 0.0005 - 0.0009	- 0.0005 - 0.0011	- 0.0002 - 0.0004	- 0.0002 - 0.0006	0 - 0.0002	0 - 0.0004
10	18	0 - 0.0003	- 0.0006 - 0.0011	- 0.0006 - 0.0013	- 0.0002 - 0.0006	- 0.0002 - 0.0007	0 - 0.0003	0 - 0.0004
18	30	0 - 0.0004	- 0.0008 - 0.0013	- 0.0008 - 0.0016	- 0.0003 - 0.0006	- 0.0003 - 0.0008	0 - 0.0004	0 - 0.0005
30	50	0 - 0.0005	- 0.0010 - 0.0016	- 0.0010 - 0.0020	- 0.0004 - 0.0008	- 0.0004 - 0.0010	0 - 0.0004	0 - 0.0006
50	65	0 - 0.0006	- 0.0012 - 0.0019	- 0.0012 - 0.0024	- 0.0004 - 0.0009	- 0.0004 - 0.0011	0 - 0.0005	0 - 0.0007
65	80	0 - 0.0006	- 0.0012 - 0.0019	- 0.0012 - 0.0024	- 0.0004 - 0.0009	- 0.0004 - 0.0011	0 - 0.0005	0 - 0.0007
80	100	0 - 0.0008	- 0.0014 - 0.0023	- 0.0014 - 0.0028	- 0.0005 - 0.0011	- 0.0005 - 0.0013	0 - 0.0006	0 - 0.0009
100	120	0 - 0.0008	- 0.0014 - 0.0023	- 0.0014 - 0.0028	- 0.0005 - 0.0011	- 0.0005 - 0.0013	0 - 0.0006	0 - 0.0009
120	140	0 - 0.0010	- 0.0017 - 0.0027	- 0.0017 - 0.0033	- 0.0006 - 0.0013	- 0.0006 - 0.0015	0 - 0.0007	0 - 0.0010
140	160	0 - 0.0010	- 0.0017 - 0.0027	- 0.0017 - 0.0033	- 0.0006 - 0.0013	- 0.0006 - 0.0015	0 - 0.0007	0 - 0.0010
160	180	0 - 0.0010	- 0.0017 - 0.0027	- 0.0017 - 0.0033	- 0.0006 - 0.0013	- 0.0006 - 0.0015	0 - 0.0007	0 - 0.0010
180	200	0 - 0.0012	- 0.0020 - 0.0031	- 0.0020 - 0.0038	- 0.0006 - 0.0014	- 0.0006 - 0.0017	0 - 0.0008	0 - 0.0011
200	225	0 - 0.0012	- 0.0020 - 0.0031	- 0.0020 - 0.0038	- 0.0006 - 0.0014	- 0.0006 - 0.0017	0 - 0.0008	0 - 0.0011
225	250	0 - 0.0012	- 0.0020 - 0.0031	- 0.0020 - 0.0038	- 0.0006 - 0.0014	- 0.0006 - 0.0017	0 - 0.0008	0 - 0.0011
250	280	0 - 0.0014	- 0.0022 - 0.0035	- 0.0022 - 0.0043	- 0.0007 - 0.0016	- 0.0007 - 0.0019	0 - 0.0009	0 - 0.0013
280	315	0 - 0.0014	- 0.0022 - 0.0035	- 0.0022 - 0.0043	- 0.0007 - 0.0016	- 0.0007 - 0.0019	0 - 0.0009	0 - 0.0013
315	355	0 - 0.0016	- 0.0024 - 0.0039	- 0.0024 - 0.0047	- 0.0007 - 0.0017	- 0.0007 - 0.0021	0 - 0.0010	0 - 0.0014
355	400	0 - 0.0016	- 0.0024 - 0.0039	- 0.0024 - 0.0047	- 0.0007 - 0.0017	- 0.0007 - 0.0021	0 - 0.0010	0 - 0.0014
400	450	0 - 0.0018	- 0.0027 - 0.0043	- 0.0027 - 0.0052	- 0.0008 - 0.0019	- 0.0008 - 0.0024	0 - 0.0011	0 - 0.0016
450	500	0 - 0.0018	- 0.0027 - 0.0043	- 0.0027 - 0.0052	- 0.0008 - 0.0019	- 0.0008 - 0.0024	0 - 0.0011	0 - 0.0016
500	560	0 - 0.0020	- 0.0030 - 0.0047	- 0.0030 - 0.0057	- 0.0009 - 0.0020	- 0.0009 - 0.0026	0 - 0.0011	0 - 0.0017
560	630	0 - 0.0020	- 0.0030 - 0.0047	- 0.0030 - 0.0057	- 0.0009 - 0.0020	- 0.0009 - 0.0026	0 - 0.0011	0 - 0.0017
630	710	0 - 0.0030	- 0.0031 - 0.0047	- 0.0031 - 0.0063	- 0.0009 - 0.0022	- 0.0009 - 0.0029	0 - 0.0013	0 - 0.0020
710	800	0 - 0.0030	- 0.0031 - 0.0051	- 0.0031 - 0.0063	- 0.0009 - 0.0022	- 0.0009 - 0.0029	0 - 0.0013	0 - 0.0020
800	900	0 - 0.0039	- 0.0034 - 0.0056	- 0.0034 - 0.0069	- 0.0010 - 0.0024	- 0.0010 - 0.0032	0 - 0.0014	0 - 0.0022
900	1000	0 - 0.0039	- 0.0034 - 0.0056	- 0.0034 - 0.0069	- 0.0010 - 0.0024	- 0.0010 - 0.0032	0 - 0.0014	0 - 0.0022
1000	1120	0 - 0.0049	- 0.0039 - 0.0065	- 0.0039 - 0.0080	- 0.0011 - 0.0028	- 0.0011 - 0.0037	0 - 0.0017	0 - 0.0026
1120	1250	0 - 0.0049	- 0.0039 - 0.0065	- 0.0039 - 0.0080	- 0.0011 - 0.0028	- 0.0011 - 0.0037	0 - 0.0017	0 - 0.0026

h7	h8	h9	h10	j5	j6	j7	DIAMETER CLASS. (MM)	
							over	incl
0 - 0.0005	0 - 0.0007	0 - 0.0012	0 - 0.0019	+ 0.0001 - 0.0001	+ 0.0002 - 0.0001	+ 0.0003 - 0.0002	3	6
0 - 0.0006	0 - 0.0009	0 - 0.0014	0 - 0.0023	+ 0.0002 - 0.0001	+ 0.0003 - 0.0001	+ 0.0004 - 0.0002	6	10
0 - 0.0007	0 - 0.0011	0 - 0.0017	0 - 0.0028	+ 0.0002 - 0.0001	+ 0.0003 - 0.0001	+ 0.0005 - 0.0002	10	18
0 - 0.0008	0 - 0.0013	0 - 0.0020	0 - 0.0033	+ 0.0002 - 0.0002	+ 0.0004 - 0.0002	+ 0.0005 - 0.0003	18	30
0 - 0.0010	0 - 0.0015	0 - 0.0024	0 - 0.0039	+ 0.0002 - 0.0002	+ 0.0004 - 0.0002	+ 0.0006 - 0.0004	30	50
0 - 0.0012	0 - 0.0018	0 - 0.0029	0 - 0.0047	+ 0.0002 - 0.0003	+ 0.0005 - 0.0003	+ 0.0007 - 0.0005	50	65
0 - 0.0012	0 - 0.0018	0 - 0.0029	0 - 0.0047	+ 0.0002 - 0.0003	+ 0.0005 - 0.0003	+ 0.0007 - 0.0005	65	80
0 - 0.0014	0 - 0.0021	0 - 0.0034	0 - 0.0055	+ 0.0002 - 0.0004	+ 0.0005 - 0.0004	+ 0.0008 - 0.0006	80	100
0 - 0.0014	0 - 0.0021	0 - 0.0034	0 - 0.0055	+ 0.0002 - 0.0004	+ 0.0005 - 0.0004	+ 0.0008 - 0.0006	100	120
0 - 0.0016	0 - 0.0025	0 - 0.0039	0 - 0.0063	+ 0.0003 - 0.0004	+ 0.0006 - 0.0004	+ 0.0009 - 0.0007	120	140
0 - 0.0016	0 - 0.0025	0 - 0.0039	0 - 0.0063	+ 0.0003 - 0.0004	+ 0.0006 - 0.0004	+ 0.0009 - 0.0007	140	160
0 - 0.0016	0 - 0.0025	0 - 0.0039	0 - 0.0063	+ 0.0003 - 0.0004	+ 0.0006 - 0.0004	+ 0.0009 - 0.0007	160	180
0 - 0.0018	0 - 0.0028	0 - 0.0045	0 - 0.0073	+ 0.0003 - 0.0005	+ 0.0006 - 0.0005	+ 0.0010 - 0.0008	180	200
0 - 0.0018	0 - 0.0028	0 - 0.0045	0 - 0.0073	+ 0.0003 - 0.0005	+ 0.0006 - 0.0005	+ 0.0010 - 0.0008	200	225
0 - 0.0018	0 - 0.0028	0 - 0.0045	0 - 0.0073	+ 0.0003 - 0.0005	+ 0.0006 - 0.0005	+ 0.0010 - 0.0008	225	250
0 - 0.0020	0 - 0.0032	0 - 0.0051	0 - 0.0083	+ 0.0003 - 0.0006	+ 0.0006 - 0.0006	+ 0.0010 - 0.0010	250	280
0 - 0.0020	0 - 0.0032	0 - 0.0051	0 - 0.0083	+ 0.0003 - 0.0006	+ 0.0006 - 0.0006	+ 0.0010 - 0.0010	280	315
0 - 0.0022	0 - 0.0035	0 - 0.0055	0 - 0.0091	+ 0.0003 - 0.0007	+ 0.0007 - 0.0007	+ 0.0011 - 0.0011	315	355
0 - 0.0022	0 - 0.0035	0 - 0.0055	0 - 0.0091	+ 0.0003 - 0.0007	+ 0.0007 - 0.0007	+ 0.0011 - 0.0011	355	400
0 - 0.0025	0 - 0.0038	0 - 0.0061	0 - 0.0098	+ 0.0003 - 0.0008	+ 0.0008 - 0.0008	+ 0.0012 - 0.0013	400	450
0 - 0.0025	0 - 0.0038	0 - 0.0061	0 - 0.0098	+ 0.0003 - 0.0008	+ 0.0008 - 0.0008	+ 0.0012 - 0.0013	450	500
0 - 0.0028	0 - 0.0043	0 - 0.0069	0 - 0.0110	- -	+ 0.0009 - 0.0009	- -	500	560
0 - 0.0028	0 - 0.0043	0 - 0.0069	0 - 0.0110	- -	+ 0.0009 - 0.0009	- -	560	630
0 - 0.0031	0 - 0.0049	0 - 0.0079	0 - 0.0126	- -	+ 0.0010 - 0.0010	- -	630	710
0 - 0.0031	0 - 0.0049	0 - 0.0079	0 - 0.0126	- -	+ 0.0010 - 0.0010	- -	710	800
0 - 0.0035	0 - 0.0055	0 - 0.0091	0 - 0.0142	- -	+ 0.0011 - 0.0011	- -	800	900
0 - 0.0035	0 - 0.0055	0 - 0.0091	0 - 0.0142	- -	+ 0.0011 - 0.0011	- -	900	1000
0 - 0.0041	0 - 0.0065	0 - 0.0102	0 - 0.0165	- -	+ 0.0013 - 0.0013	- -	1000	1120
0 - 0.0041	0 - 0.0065	0 - 0.0102	0 - 0.0165	- -	+ 0.0013 - 0.0013	- -	1120	1250

TOLERANCES FOR SHAFT DIAMETERS

Table 10 - Tolerances for Shaft Diameters

Units: inch

DIAMETER CLASS. (MM)		SINGLE PLANE MEAN B.D. DEVIATION (NORMAL)	js4	js5	js6	k4	k5	k6	k7
over	incl	Δ dmp							
3	6	0 - 0.0003	+ 0.0001 - 0.0001	+ 0.0001 - 0.0001	+ 0.0002 - 0.0002	+ 0.0002 0	+ 0.0002 0	+ 0.0004 0	+ 0.0005 0
6	10	0 - 0.0003	+ 0.0001 - 0.0001	+ 0.0001 - 0.0001	+ 0.0002 - 0.0002	+ 0.0002 0	+ 0.0003 0	+ 0.0004 0	+ 0.0006 0
10	18	0 - 0.0003	+ 0.0001 - 0.0001	+ 0.0002 - 0.0002	+ 0.0002 - 0.0002	+ 0.0002 0	+ 0.0004 0	+ 0.0005 0	+ 0.0007 0
18	30	0 - 0.0004	+ 0.0001 - 0.0001	+ 0.0002 - 0.0002	+ 0.0003 - 0.0003	+ 0.0003 + 0.0001	+ 0.0004 + 0.0001	+ 0.0006 + 0.0001	+ 0.0009 + 0.0001
30	50	0 - 0.0005	+ 0.0001 - 0.0001	+ 0.0002 - 0.0002	+ 0.0003 - 0.0003	+ 0.0004 + 0.0001	+ 0.0005 + 0.0001	+ 0.0007 + 0.0001	+ 0.0011 + 0.0001
50	65	0 - 0.0006	+ 0.0002 - 0.0002	+ 0.0003 - 0.0003	+ 0.0004 - 0.0004	+ 0.0004 + 0.0001	+ 0.0006 + 0.0001	+ 0.0008 + 0.0001	+ 0.0013 + 0.0001
65	80	0 - 0.0006	+ 0.0002 - 0.0002	+ 0.0003 - 0.0003	+ 0.0004 - 0.0004	+ 0.0004 + 0.0001	+ 0.0006 + 0.0001	+ 0.0008 + 0.0001	+ 0.0013 + 0.0001
80	100	0 - 0.0008	+ 0.0002 - 0.0002	+ 0.0003 - 0.0003	+ 0.0004 - 0.0004	+ 0.0005 + 0.0001	+ 0.0007 + 0.0001	+ 0.0010 + 0.0001	+ 0.0015 + 0.0001
100	120	0 - 0.0008	+ 0.0002 - 0.0002	+ 0.0003 - 0.0003	+ 0.0004 - 0.0004	+ 0.0005 + 0.0001	+ 0.0007 + 0.0001	+ 0.0010 + 0.0001	+ 0.0015 + 0.0001
120	140	0 - 0.0010	+ 0.0002 - 0.0002	+ 0.0004 - 0.0004	+ 0.0005 - 0.0005	+ 0.0006 + 0.0001	+ 0.0008 + 0.0001	+ 0.0011 + 0.0001	+ 0.0017 + 0.0001
140	160	0 - 0.0010	+ 0.0002 - 0.0002	+ 0.0004 - 0.0004	+ 0.0005 - 0.0005	+ 0.0006 + 0.0001	+ 0.0008 + 0.0001	+ 0.0011 + 0.0001	+ 0.0017 + 0.0001
160	180	0 - 0.0010	+ 0.0002 - 0.0002	+ 0.0004 - 0.0004	+ 0.0005 - 0.0005	+ 0.0006 + 0.0001	+ 0.0008 + 0.0001	+ 0.0011 + 0.0001	+ 0.0017 + 0.0001
180	200	0 - 0.0012	+ 0.0003 - 0.0003	+ 0.0004 - 0.0004	+ 0.0006 - 0.0006	+ 0.0007 + 0.0002	+ 0.0009 + 0.0002	+ 0.0013 + 0.0002	+ 0.0020 + 0.0002
200	225	0 - 0.0012	+ 0.0003 - 0.0003	+ 0.0004 - 0.0004	+ 0.0006 - 0.0006	+ 0.0007 + 0.0002	+ 0.0009 + 0.0002	+ 0.0013 + 0.0002	+ 0.0020 + 0.0002
225	250	0 - 0.0012	+ 0.0003 - 0.0003	+ 0.0004 - 0.0004	+ 0.0006 - 0.0006	+ 0.0007 + 0.0002	+ 0.0009 + 0.0002	+ 0.0013 + 0.0002	+ 0.0020 + 0.0002
250	280	0 - 0.0014	+ 0.0003 - 0.0003	+ 0.0005 - 0.0005	+ 0.0006 - 0.0006	+ 0.0008 + 0.0002	+ 0.0011 + 0.0002	+ 0.0014 + 0.0002	+ 0.0022 + 0.0002
280	315	0 - 0.0014	+ 0.0003 - 0.0003	+ 0.0005 - 0.0005	+ 0.0006 - 0.0006	+ 0.0008 + 0.0002	+ 0.0011 + 0.0002	+ 0.0014 + 0.0002	+ 0.0022 + 0.0002
315	355	0 - 0.0016	+ 0.0004 - 0.0004	+ 0.0005 - 0.0005	+ 0.0007 - 0.0007	+ 0.0009 + 0.0002	+ 0.0011 + 0.0002	+ 0.0016 + 0.0002	+ 0.0024 + 0.0002
355	400	0 - 0.0016	+ 0.0004 - 0.0004	+ 0.0005 - 0.0005	+ 0.0007 - 0.0007	+ 0.0009 + 0.0002	+ 0.0011 + 0.0002	+ 0.0016 + 0.0002	+ 0.0024 + 0.0002
400	450	0 - 0.0018	+ 0.0004 - 0.0004	+ 0.0005 - 0.0005	+ 0.0008 - 0.0008	+ 0.0010 + 0.0002	+ 0.0013 + 0.0002	+ 0.0018 + 0.0002	+ 0.0027 + 0.0002
450	500	0 - 0.0018	+ 0.0004 - 0.0004	+ 0.0005 - 0.0005	+ 0.0008 - 0.0008	+ 0.0010 + 0.0002	+ 0.0013 + 0.0002	+ 0.0018 + 0.0002	+ 0.0027 + 0.0002
500	560	0 - 0.0020	- -	+ 0.0006 - 0.0006	+ 0.0009 - 0.0009	- -	+ 0.0011 0	+ 0.0017 0	+ 0.0028 0
560	630	0 - 0.0020	- -	+ 0.0006 - 0.0006	+ 0.0009 - 0.0009	- -	+ 0.0011 0	+ 0.0017 0	+ 0.0028 0
630	710	0 - 0.0030	- -	+ 0.0006 - 0.0006	+ 0.0010 - 0.0010	- -	+ 0.0013 0	+ 0.0020 0	+ 0.0031 0
710	800	0 - 0.0030	- -	+ 0.0006 - 0.0006	+ 0.0010 - 0.0010	- -	+ 0.0013 0	+ 0.0020 0	+ 0.0031 0
800	900	0 - 0.0039	- -	+ 0.0007 - 0.0007	+ 0.0011 - 0.0011	- -	+ 0.0014 0	+ 0.0022 0	+ 0.0035 0
900	1000	0 - 0.0039	- -	+ 0.0007 - 0.0007	+ 0.0011 - 0.0011	- -	+ 0.0014 0	+ 0.0022 0	+ 0.0035 0
1000	1120	0 - 0.0049	- -	+ 0.0008 - 0.0008	+ 0.0013 - 0.0013	- -	+ 0.0017 0	+ 0.0026 0	+ 0.0041 0
1120	1250	0 - 0.0049	- -	+ 0.0008 - 0.0008	+ 0.0013 - 0.0013	- -	+ 0.0017 0	+ 0.0026 0	+ 0.0041 0

m5	m6	n5	n6	p6	p7	r6	r7	DIAMETER CLASS. (MM)	
								over	incl
+ 0.0004 + 0.0002	+ 0.0005 + 0.0002	+ 0.0005 + 0.0003	+ 0.0006 + 0.0003	+ 0.0008 + 0.0005	+ 0.0009 + 0.0005	+ 0.0009 + 0.0006	+ 0.0011 + 0.0006	3	6
+ 0.0005 + 0.0002	+ 0.0006 + 0.0002	+ 0.0006 + 0.0004	+ 0.0007 + 0.0004	+ 0.0009 + 0.0006	+ 0.0012 + 0.0006	+ 0.0011 + 0.0007	+ 0.0013 + 0.0007	6	10
+ 0.0006 + 0.0003	+ 0.0007 + 0.0003	+ 0.0008 + 0.0005	+ 0.0009 + 0.0005	+ 0.0011 + 0.0007	+ 0.0014 + 0.0007	+ 0.0013 + 0.0009	+ 0.0016 + 0.0009	10	18
+ 0.0007 + 0.0003	+ 0.0008 + 0.0003	+ 0.0009 + 0.0006	+ 0.0011 + 0.0006	+ 0.0014 + 0.0009	+ 0.0017 + 0.0009	+ 0.0016 + 0.0011	+ 0.0019 + 0.0011	18	30
+ 0.0008 + 0.0004	+ 0.0010 + 0.0004	+ 0.0011 + 0.0007	+ 0.0013 + 0.0007	+ 0.0017 + 0.0010	+ 0.0020 + 0.0010	+ 0.0020 + 0.0013	+ 0.0023 + 0.0013	30	50
+ 0.0009 + 0.0004	+ 0.0012 + 0.0004	+ 0.0013 + 0.0008	+ 0.0015 + 0.0008	+ 0.0020 + 0.0013	+ 0.0024 + 0.0013	+ 0.0024 + 0.0016	+ 0.0028 + 0.0016	50	65
+ 0.0009 + 0.0004	+ 0.0012 + 0.0004	+ 0.0013 + 0.0008	+ 0.0015 + 0.0008	+ 0.0020 + 0.0013	+ 0.0024 + 0.0013	+ 0.0024 + 0.0017	+ 0.0029 + 0.0017	65	80
+ 0.0011 + 0.0005	+ 0.0014 + 0.0005	+ 0.0015 + 0.0009	+ 0.0018 + 0.0009	+ 0.0023 + 0.0015	+ 0.0028 + 0.0015	+ 0.0029 + 0.0020	+ 0.0034 + 0.0020	80	100
+ 0.0011 + 0.0005	+ 0.0014 + 0.0005	+ 0.0015 + 0.0009	+ 0.0018 + 0.0009	+ 0.0023 + 0.0015	+ 0.0028 + 0.0015	+ 0.0030 + 0.0021	+ 0.0035 + 0.0021	100	120
+ 0.0013 + 0.0006	+ 0.0016 + 0.0006	+ 0.0018 + 0.0011	+ 0.0020 + 0.0011	+ 0.0027 + 0.0017	+ 0.0033 + 0.0017	+ 0.0035 + 0.0025	+ 0.0041 + 0.0025	120	140
+ 0.0013 + 0.0006	+ 0.0016 + 0.0006	+ 0.0018 + 0.0011	+ 0.0020 + 0.0011	+ 0.0027 + 0.0017	+ 0.0033 + 0.0017	+ 0.0035 + 0.0026	+ 0.0041 + 0.0026	140	160
+ 0.0013 + 0.0006	+ 0.0016 + 0.0006	+ 0.0018 + 0.0011	+ 0.0020 + 0.0011	+ 0.0027 + 0.0017	+ 0.0033 + 0.0017	+ 0.0037 + 0.0027	+ 0.0043 + 0.0027	160	180
+ 0.0015 + 0.0007	+ 0.0018 + 0.0007	+ 0.0020 + 0.0012	+ 0.0024 + 0.0012	+ 0.0031 + 0.0020	+ 0.0038 + 0.0020	+ 0.0042 + 0.0030	+ 0.0048 + 0.0030	180	200
+ 0.0015 + 0.0007	+ 0.0018 + 0.0007	+ 0.0020 + 0.0012	+ 0.0024 + 0.0012	+ 0.0031 + 0.0020	+ 0.0038 + 0.0020	+ 0.0043 + 0.0031	+ 0.0050 + 0.0031	200	225
+ 0.0015 + 0.0007	+ 0.0018 + 0.0007	+ 0.0020 + 0.0012	+ 0.0024 + 0.0012	+ 0.0031 + 0.0020	+ 0.0038 + 0.0020	+ 0.0044 + 0.0033	+ 0.0051 + 0.0033	225	250
+ 0.0017 + 0.0008	+ 0.0020 + 0.0008	+ 0.0022 + 0.0013	+ 0.0026 + 0.0013	+ 0.0035 + 0.0022	+ 0.0043 + 0.0022	+ 0.0050 + 0.0037	+ 0.0057 + 0.0037	250	280
+ 0.0017 + 0.0008	+ 0.0020 + 0.0008	+ 0.0022 + 0.0013	+ 0.0026 + 0.0013	+ 0.0035 + 0.0022	+ 0.0043 + 0.0022	+ 0.0051 + 0.0039	+ 0.0059 + 0.0039	280	315
+ 0.0018 + 0.0008	+ 0.0022 + 0.0008	+ 0.0024 + 0.0015	+ 0.0029 + 0.0015	+ 0.0039 + 0.0024	+ 0.0047 + 0.0024	+ 0.0057 + 0.0043	+ 0.0065 + 0.0043	315	355
+ 0.0018 + 0.0008	+ 0.0022 + 0.0008	+ 0.0024 + 0.0015	+ 0.0029 + 0.0015	+ 0.0039 + 0.0024	+ 0.0047 + 0.0024	+ 0.0059 + 0.0045	+ 0.0067 + 0.0045	355	400
+ 0.0020 + 0.0009	+ 0.0025 + 0.0009	+ 0.0026 + 0.0016	+ 0.0031 + 0.0016	+ 0.0043 + 0.0027	+ 0.0052 + 0.0027	+ 0.0065 + 0.0050	+ 0.0074 + 0.0050	400	450
+ 0.0020 + 0.0009	+ 0.0025 + 0.0009	+ 0.0026 + 0.0016	+ 0.0031 + 0.0016	+ 0.0043 + 0.0027	+ 0.0052 + 0.0027	+ 0.0068 + 0.0052	+ 0.0077 + 0.0052	450	500
+ 0.0022 + 0.0010	+ 0.0028 + 0.0010	+ 0.0029 + 0.0017	+ 0.0035 + 0.0017	+ 0.0048 + 0.0031	+ 0.0058 + 0.0031	+ 0.0076 + 0.0059	+ 0.0087 + 0.0059	500	560
+ 0.0022 + 0.0010	+ 0.0028 + 0.0010	+ 0.0029 + 0.0017	+ 0.0035 + 0.0017	+ 0.0048 + 0.0031	+ 0.0058 + 0.0031	+ 0.0078 + 0.0061	+ 0.0089 + 0.0061	560	630
+ 0.0024 + 0.0012	+ 0.0031 + 0.0012	+ 0.0032 + 0.0020	+ 0.0039 + 0.0020	+ 0.0054 + 0.0035	+ 0.0066 + 0.0035	+ 0.0089 + 0.0069	+ 0.0100 + 0.0069	630	710
+ 0.0024 + 0.0012	+ 0.0031 + 0.0012	+ 0.0032 + 0.0020	+ 0.0039 + 0.0020	+ 0.0054 + 0.0035	+ 0.0066 + 0.0035	+ 0.0093 + 0.0073	+ 0.0104 + 0.0073	710	800
+ 0.0028 + 0.0013	+ 0.0035 + 0.0013	+ 0.0036 + 0.0022	+ 0.0044 + 0.0022	+ 0.0061 + 0.0039	+ 0.0075 + 0.0039	+ 0.0105 + 0.0083	+ 0.0118 + 0.0083	800	900
+ 0.0028 + 0.0013	+ 0.0035 + 0.0013	+ 0.0036 + 0.0022	+ 0.0044 + 0.0022	+ 0.0061 + 0.0039	+ 0.0075 + 0.0039	+ 0.0109 + 0.0087	+ 0.0122 + 0.0087	900	1000
+ 0.0032 + 0.0016	+ 0.0042 + 0.0016	+ 0.0043 + 0.0026	+ 0.0052 + 0.0026	+ 0.0073 + 0.0047	+ 0.0089 + 0.0047	+ 0.0124 + 0.0098	+ 0.0140 + 0.0098	1000	1120
+ 0.0032 + 0.0016	+ 0.0042 + 0.0016	+ 0.0043 + 0.0026	+ 0.0052 + 0.0026	+ 0.0073 + 0.0047	+ 0.0089 + 0.0047	+ 0.0128 + 0.0102	+ 0.0144 + 0.0102	1120	1250

TOLERANCES FOR HOUSING DIAMETERS

Table 11 - Tolerances for Housing Bore Diameters

Units: inch

DIAMETER CLASS. (MM)		SINGLE PLANE MEAN B.D. DEVIATION (NORMAL)	F7	G6	G7	H6	H7	H8
Over	incl	Δ dmp						
10	18	0	+ 0.0013	+ 0.0007	+ 0.0009	+ 0.0004	+ 0.0007	+ 0.0011
		- 0.0003	+ 0.0006	+ 0.0002	+ 0.0002	0	0	0
18	30	0	+ 0.0016	+ 0.0008	+ 0.0011	+ 0.0005	+ 0.0008	+ 0.0013
		- 0.0004	+ 0.0008	+ 0.0003	+ 0.0003	0	0	0
30	50	0	+ 0.0020	+ 0.0010	+ 0.0013	+ 0.0006	+ 0.0010	+ 0.0015
		- 0.0004	+ 0.0010	+ 0.0004	+ 0.0004	0	0	0
50	80	0	+ 0.0024	+ 0.0011	+ 0.0016	+ 0.0007	+ 0.0012	+ 0.0018
		- 0.0005	+ 0.0012	+ 0.0004	+ 0.0004	0	0	0
80	120	0	+ 0.0028	+ 0.0013	+ 0.0019	+ 0.0009	+ 0.0014	+ 0.0021
		- 0.0006	+ 0.0014	+ 0.0005	+ 0.0005	0	0	0
120	150	0	+ 0.0033	+ 0.0015	+ 0.0021	+ 0.0010	+ 0.0016	+ 0.0025
		- 0.0007	+ 0.0017	+ 0.0006	+ 0.0006	0	0	0
150	180	0	+ 0.0033	+ 0.0015	+ 0.0021	+ 0.0010	+ 0.0016	+ 0.0025
		- 0.0010	+ 0.0017	+ 0.0006	+ 0.0006	0	0	0
180	250	0	+ 0.0038	+ 0.0017	+ 0.0024	+ 0.0011	+ 0.0018	+ 0.0028
		- 0.0012	+ 0.0020	+ 0.0006	+ 0.0006	0	0	0
250	315	0	+ 0.0043	+ 0.0019	+ 0.0027	+ 0.0013	+ 0.0020	+ 0.0032
		- 0.0014	+ 0.0022	+ 0.0007	+ 0.0007	0	0	0
315	400	0	+ 0.0047	+ 0.0021	+ 0.0030	+ 0.0014	+ 0.0022	+ 0.0035
		- 0.0016	+ 0.0024	+ 0.0007	+ 0.0007	0	0	0
400	500	0	+ 0.0052	+ 0.0024	+ 0.0033	+ 0.0016	+ 0.0025	+ 0.0038
		- 0.0018	+ 0.0027	+ 0.0008	+ 0.0008	0	0	0
500	630	0	+ 0.0057	+ 0.0026	+ 0.0036	+ 0.0017	+ 0.0028	+ 0.0043
		- 0.0020	+ 0.0030	+ 0.0009	+ 0.0009	0	0	0
630	800	0	+ 0.0063	+ 0.0029	+ 0.0041	+ 0.0020	+ 0.0031	+ 0.0049
		- 0.0030	+ 0.0031	+ 0.0009	+ 0.0009	0	0	0
800	1000	0	+ 0.0069	+ 0.0032	+ 0.0046	+ 0.0022	+ 0.0035	+ 0.0055
		- 0.0039	+ 0.0034	+ 0.0010	+ 0.0010	0	0	0
1000	1250	0	+ 0.0080	+ 0.0037	+ 0.0052	+ 0.0026	+ 0.0041	+ 0.0065
		- 0.0049	+ 0.0039	+ 0.0011	+ 0.0011	0	0	0
2150	1600	0	+ 0.0093	+ 0.0043	+ 0.0061	+ 0.0031	+ 0.0049	+ 0.0077
		- 0.0063	+ 0.0043	+ 0.0012	+ 0.0012	0	0	0
1600	2000	0	+ 0.0106	+ 0.0049	+ 0.0072	+ 0.0036	+ 0.0059	+ 0.0091
		- 0.0079	+ 0.0047	+ 0.0013	+ 0.0013	0	0	0
2000	2500	0	+ 0.0120	+ 0.0057	+ 0.0082	+ 0.0043	+ 0.0069	+ 0.0110
		- 0.0098	+ 0.0051	+ 0.0013	+ 0.0013	0	0	0

H9	H10	J6	J7	JS5	JS6	JS7	DIAMETER CLASS. (MM)	
							Over	incl
+ 0.0017 0	+ 0.0028 0	+ 0.0002 - 0.0002	+ 0.0004 - 0.0003	+ 0.0002 - 0.0002	+ 0.0002 - 0.0002	+ 0.0004 - 0.0004	10	18
+ 0.0020 0	+ 0.0033 0	+ 0.0003 - 0.0002	+ 0.0005 - 0.0004	+ 0.0002 - 0.0002	+ 0.0003 - 0.0003	+ 0.0004 - 0.0004	18	30
+ 0.0024 0	+ 0.0039 0	+ 0.0004 - 0.0002	+ 0.0006 - 0.0004	+ 0.0002 - 0.0002	+ 0.0003 - 0.0003	+ 0.0005 - 0.0005	30	50
+ 0.0029 0	+ 0.0047 0	+ 0.0005 - 0.0002	+ 0.0007 - 0.0005	+ 0.0003 - 0.0003	+ 0.0004 - 0.0004	+ 0.0006 - 0.0006	50	80
+ 0.0034 0	+ 0.0055 0	+ 0.0006 - 0.0002	+ 0.0009 - 0.0005	+ 0.0003 - 0.0003	+ 0.0004 - 0.0004	+ 0.0007 - 0.0007	80	120
+ 0.0039 0	+ 0.0063 0	+ 0.0007 - 0.0003	+ 0.0010 - 0.0006	+ 0.0004 - 0.0004	+ 0.0005 - 0.0005	+ 0.0008 - 0.0008	120	150
+ 0.0039 0	+ 0.0063 0	+ 0.0007 - 0.0003	+ 0.0010 - 0.0006	+ 0.0004 - 0.0004	+ 0.0005 - 0.0005	+ 0.0008 - 0.0008	150	180
+ 0.0045 0	+ 0.0073 0	+ 0.0009 - 0.0003	+ 0.0012 - 0.0006	+ 0.0004 - 0.0004	+ 0.0006 - 0.0006	+ 0.0009 - 0.0009	180	250
+ 0.0051 0	+ 0.0083 0	+ 0.0010 - 0.0003	+ 0.0014 - 0.0006	+ 0.0005 - 0.0005	+ 0.0006 - 0.0006	+ 0.0010 - 0.0010	250	315
+ 0.0055 0	+ 0.0091 0	+ 0.0011 - 0.0003	+ 0.0015 - 0.0007	+ 0.0005 - 0.0005	+ 0.0007 - 0.0007	+ 0.0011 - 0.0011	315	400
+ 0.0061 0	+ 0.0098 0	+ 0.0013 - 0.0003	+ 0.0017 - 0.0008	+ 0.0005 - 0.0005	+ 0.0008 - 0.0008	+ 0.0012 - 0.0012	400	500
+ 0.0069 0	+ 0.0110 0	- -	- -	+ 0.0006 - 0.0006	+ 0.0009 - 0.0009	+ 0.0014 - 0.0014	500	630
+ 0.0079 0	+ 0.0126 0	- -	- -	+ 0.0006 - 0.0006	+ 0.0010 - 0.0010	+ 0.0016 - 0.0016	630	800
+ 0.0091 0	+ 0.0142 0	- -	- -	+ 0.0007 - 0.0007	+ 0.0011 - 0.0011	+ 0.0018 - 0.0018	800	1000
+ 0.0102 0	+ 0.0165 0	- -	- -	+ 0.0008 - 0.0008	+ 0.0013 - 0.0013	+ 0.0021 - 0.0021	1000	1250
+ 0.0122 0	+ 0.0197 0	- -	- -	+ 0.0010 - 0.0010	+ 0.0015 - 0.0015	+ 0.0025 - 0.0025	2150	1600
+ 0.0146 0	+ 0.0236 0	- -	- -	+ 0.0012 - 0.0012	+ 0.0018 - 0.0018	+ 0.0030 - 0.0030	1600	2000
+ 0.0173 0	+ 0.0276 0	- -	- -	+ 0.0014 - 0.0014	+ 0.0022 - 0.0022	+ 0.0034 - 0.0034	2000	2500

TOLERANCES FOR HOUSING DIAMETERS

Table 11 - Tolerances for Housing Bore Diameters

Units: inch

DIAMETER CLASS. (MM)		SINGLE PLANE MEAN B.D. DEVIATION (NORMAL)	K5	K6	K7	M5	M6
Over	incl	Δ dmp					
10	18	0	+ 0.0001	+ 0.0001	+ 0.0002	- 0.0002	- 0.0002
		- 0.0003	- 0.0002	- 0.0004	- 0.0005	- 0.0005	- 0.0006
18	30	0	0	+ 0.0001	+ 0.0002	- 0.0002	- 0.0002
		- 0.0004	- 0.0003	- 0.0004	- 0.0006	- 0.0006	- 0.0007
30	50	0	+ 0.0001	+ 0.0001	+ 0.0003	- 0.0002	- 0.0002
		- 0.0004	- 0.0004	- 0.0005	- 0.0007	- 0.0006	- 0.0008
50	80	0	+ 0.0001	+ 0.0002	+ 0.0004	- 0.0002	- 0.0002
		- 0.0005	- 0.0004	- 0.0006	- 0.0008	- 0.0007	- 0.0009
80	120	0	+ 0.0001	+ 0.0002	+ 0.0004	- 0.0003	- 0.0002
		- 0.0006	- 0.0005	- 0.0007	- 0.0010	- 0.0009	- 0.0011
120	150	0	+ 0.0001	+ 0.0002	+ 0.0005	- 0.0004	- 0.0003
		- 0.0007	- 0.0006	- 0.0008	- 0.0011	- 0.0011	- 0.0013
150	180	0	+ 0.0001	+ 0.0002	+ 0.0005	- 0.0004	- 0.0003
		- 0.0010	- 0.0006	- 0.0008	- 0.0011	- 0.0011	- 0.0013
180	250	0	+ 0.0001	+ 0.0002	+ 0.0005	- 0.0004	- 0.0003
		- 0.0012	- 0.0007	- 0.0009	- 0.0013	- 0.0012	- 0.0015
250	315	0	+ 0.0001	+ 0.0002	+ 0.0006	- 0.0005	- 0.0004
		- 0.0014	- 0.0008	- 0.0011	- 0.0014	- 0.0014	- 0.0016
315	400	0	+ 0.0001	+ 0.0003	+ 0.0007	- 0.0006	- 0.0004
		- 0.0016	- 0.0009	- 0.0011	- 0.0016	- 0.0015	- 0.0018
400	500	0	+ 0.0001	+ 0.0003	+ 0.0007	- 0.0006	- 0.0004
		- 0.0018	- 0.0010	- 0.0013	- 0.0018	- 0.0017	- 0.0020
500	630	0	-	0	0	-	- 0.0010
		- 0.0020	-	- 0.0017	- 0.0028	-	- 0.0028
630	800	0	-	0	0	-	- 0.0012
		- 0.0030	-	- 0.0020	- 0.0031	-	- 0.0031
800	1000	0	-	0	0	-	- 0.0013
		- 0.0039	-	- 0.0022	- 0.0035	-	- 0.0035
1000	1250	0	-	0	0	-	- 0.0016
		- 0.0049	-	- 0.0026	- 0.0041	-	- 0.0042
2150	1600	0	-	0	0	-	- 0.0019
		- 0.0063	-	- 0.0031	- 0.0049	-	- 0.0050
1600	2000	0	-	0	0	-	- 0.0023
		- 0.0079	-	- 0.0036	- 0.0059	-	- 0.0059
2000	2500	0	-	0	0	-	- 0.0027
		- 0.0098	-	- 0.0043	- 0.0069	-	- 0.0070

M7	N6	N7	P6	P7	DIAMETER CLASS. (MM)	
					Over	incl
0 - 0.0007	- 0.0004 - 0.0008	- 0.0002 - 0.0009	- 0.0006 - 0.0010	- 0.0004 - 0.0011	10	18
0 - 0.0008	- 0.0004 - 0.0009	- 0.0003 - 0.0011	- 0.0007 - 0.0012	- 0.0006 - 0.0014	18	30
0 - 0.0010	- 0.0005 - 0.0011	- 0.0003 - 0.0013	- 0.0008 - 0.0015	- 0.0007 - 0.0017	30	50
0 - 0.0012	- 0.0006 - 0.0013	- 0.0004 - 0.0015	- 0.0010 - 0.0018	- 0.0008 - 0.0020	50	80
0 - 0.0014	- 0.0006 - 0.0015	- 0.0004 - 0.0018	- 0.0012 - 0.0020	- 0.0009 - 0.0023	80	120
0 - 0.0016	- 0.0008 - 0.0018	- 0.0005 - 0.0020	- 0.0014 - 0.0024	- 0.0011 - 0.0027	120	150
0 - 0.0016	- 0.0008 - 0.0018	- 0.0005 - 0.0020	- 0.0014 - 0.0024	- 0.0011 - 0.0027	150	180
0 - 0.0018	- 0.0009 - 0.0020	- 0.0006 - 0.0024	- 0.0016 - 0.0028	- 0.0013 - 0.0031	180	250
0 - 0.0020	- 0.0010 - 0.0022	- 0.0006 - 0.0026	- 0.0019 - 0.0031	- 0.0014 - 0.0035	250	315
0 - 0.0022	- 0.0010 - 0.0024	- 0.0006 - 0.0029	- 0.0020 - 0.0034	- 0.0016 - 0.0039	315	400
0 - 0.0025	- 0.0011 - 0.0026	- 0.0007 - 0.0031	- 0.0022 - 0.0037	- 0.0018 - 0.0043	400	500
- 0.0010 - 0.0038	- 0.0017 - 0.0035	- 0.0017 - 0.0045	- 0.0031 - 0.0048	- 0.0031 - 0.0058	500	630
- 0.0012 - 0.0043	- 0.0020 - 0.0039	- 0.0020 - 0.0051	- 0.0035 - 0.0054	- 0.0035 - 0.0066	630	800
- 0.0013 - 0.0049	- 0.0022 - 0.0044	- 0.0022 - 0.0057	- 0.0039 - 0.0061	- 0.0039 - 0.0075	800	1000
- 0.0016 - 0.0057	- 0.0026 - 0.0052	- 0.0026 - 0.0067	- 0.0047 - 0.0073	- 0.0047 - 0.0089	1000	1250
- 0.0019 - 0.0068	- 0.0031 - 0.0061	- 0.0031 - 0.0080	- 0.0055 - 0.0086	- 0.0055 - 0.0104	2150	1600
- 0.0023 - 0.0082	- 0.0036 - 0.0072	- 0.0036 - 0.0095	- 0.0067 - 0.0103	- 0.0067 - 0.0126	1600	2000
- 0.0027 - 0.0096	- 0.0043 - 0.0087	- 0.0043 - 0.0112	- 0.0077 - 0.0120	- 0.0077 - 0.0146	2000	2500

SHAFT BEARING-SEAT DIAMETERS

Table 12 - Shaft Diameters and Resulting Fits

Units: inch

BEARING BORE DIAMETER				SHAFT DIAMETER / RESULTING FIT (0.0001")										
mm	in		f6		RESULTING FIT	f7		RESULTING FIT	g5		RESULTING FIT	g6		RESULTING FIT
Shaft	max	min	max	min		max	min		max	min		max	min	
4	0.1575	0.1572	0.1571	0.1568	7 L / 1 L	0.1571	0.1566	9 L / 1 L	0.1573	0.1571	4 L / 2 T	0.1573	0.1570	5 L / 2 T
5	0.1969	0.1965	0.1965	0.1961		0.1965	0.1960		0.1967	0.1965		0.1967	0.1964	
6	0.2362	0.2359	0.2358	0.2355		0.2358	0.2354		0.2361	0.2359		0.2361	0.2357	
7	0.2756	0.2753	0.2751	0.2747	9 L / 2 L	0.2751	0.2745	11 L / 2 L	0.2754	0.2752	4 L / 1 T	0.2754	0.2750	6 L / 1 T
8	0.3150	0.3146	0.3144	0.3141		0.3144	0.3139		0.3148	0.3145		0.3148	0.3144	
9	0.3543	0.3540	0.3538	0.3535		0.3538	0.3532		0.3541	0.3539		0.3541	0.3538	
10	0.3937	0.3934	0.3932	0.3928		0.3932	0.3926		0.3935	0.3933		0.3935	0.3931	
12	0.4724	0.4721	0.4718	0.4714	11 L / 3 L	0.4718	0.4711	13 L / 3 L	0.4722	0.4719	6 L / 1 T	0.4722	0.4718	7 L / 1 T
15	0.5906	0.5902	0.5899	0.5895		0.5899	0.5892		0.5903	0.5900		0.5903	0.5899	
17	0.6693	0.6690	0.6687	0.6682		0.6687	0.6680		0.6691	0.6687		0.6691	0.6686	
20	0.7874	0.7870	0.7866	0.7861	13 L / 4 L	0.7866	0.7858	16 L / 4 L	0.7871	0.7868	6 L / 1 T	0.7871	0.7866	8 L / 1 T
25	0.9843	0.9839	0.9835	0.9830		0.9835	0.9826		0.9840	0.9836		0.9840	0.9835	
30	1.1811	1.1807	1.1803	1.1798		1.1803	1.1795		1.1808	1.1805		1.1808	1.1803	
35	1.3780	1.3775	1.3770	1.3763	16 L / 5 L	1.3770	1.3760	20 L / 5 L	1.3776	1.3772	8 L / 1 T	1.3776	1.3770	10 L / 1 T
40	1.5748	1.5743	1.5738	1.5732		1.5738	1.5728		1.5744	1.5740		1.5744	1.5738	
45	1.7717	1.7712	1.7707	1.7700		1.7707	1.7697		1.7713	1.7709		1.7713	1.7707	
50	1.9685	1.9680	1.9675	1.9669		1.9675	1.9665		1.9681	1.9677		1.9681	1.9675	
55	2.1654	2.1648	2.1642	2.1634	19 L / 6 L	2.1642	2.1630	24 L / 6 L	2.1650	2.1644	9 L / 2 T	2.1650	2.1642	11 L / 2 T
60	2.3622	2.3616	2.3610	2.3603		2.3610	2.3598		2.3618	2.3613		2.3618	2.3611	
65	2.5591	2.5585	2.5579	2.5571		2.5579	2.5567		2.5587	2.5581		2.5587	2.5579	
70	2.7559	2.7553	2.7547	2.7540		2.7547	2.7535		2.7555	2.7550		2.7555	2.7548	
75	2.9528	2.9522	2.9516	2.9508		2.9516	2.9504		2.9524	2.9519		2.9524	2.9516	
80	3.1496	3.1490	3.1484	3.1477	3.1484	3.1472	3.1492	3.1487	3.1492	3.1485				
85	3.3465	3.3457	3.3450	3.3442	23 L / 6 L	3.3450	3.3437	28 L / 6 L	3.3460	3.3454	11 L / 3 T	3.3460	3.3451	13 L / 3 T
90	3.5433	3.5425	3.5419	3.5410		3.5419	3.5405		3.5428	3.5422		3.5428	3.5420	
95	3.7402	3.7394	3.7387	3.7379		3.7387	3.7374		3.7397	3.7391		3.7397	3.7388	
100	3.9370	3.9362	3.9356	3.9347		3.9356	3.9342		3.9365	3.9359		3.9365	3.9357	
105	4.1339	4.1331	4.1324	4.1316		4.1324	4.1311		4.1334	4.1328		4.1334	4.1325	
110	4.3307	4.3299	4.3293	4.3284		4.3293	4.3279		4.3302	4.3296		4.3302	4.3294	
120	4.7244	4.7236	4.7230	4.7221	4.7230	4.7216	4.7239	4.7233	4.7239	4.7231				
130	5.1181	5.1171	5.1164	5.1154	27 L / 7 L	5.1164	5.1148	33 L / 7 L	5.1176	5.1169	13 L / 4 T	5.1176	5.1166	15 L / 4 T
140	5.5118	5.5108	5.5101	5.5091		5.5101	5.5085		5.5113	5.5106		5.5113	5.5103	
150	5.9055	5.9045	5.9038	5.9028		5.9038	5.9022		5.9050	5.9043		5.9050	5.9040	
160	6.2992	6.2982	6.2975	6.2965		6.2975	6.2959		6.2987	6.2980		6.2987	6.2977	
170	6.6929	6.6919	6.6912	6.6902		6.6912	6.6896		6.6924	6.6917		6.6924	6.6914	
180	7.0866	7.0856	7.0849	7.0839		7.0849	7.0833		7.0861	7.0854		7.0861	7.0851	
190	7.4803	7.4791	7.4783	7.4772	31 L / 8 L	7.4783	7.4765	38 L / 8 L	7.4797	7.4789	14 L / 6 T	7.4797	7.4786	17 L / 6 T
200	7.8740	7.8728	7.8720	7.8709		7.8720	7.8702		7.8734	7.8726		7.8734	7.8723	
220	8.6614	8.6602	8.6594	8.6583		8.6594	8.6576		8.6608	8.6600		8.6608	8.6597	
240	9.4488	9.4476	9.4469	9.4457		9.4469	9.4450		9.4482	9.4474		9.4482	9.4471	
260	10.2362	10.2348	10.2340	10.2328	35 L / 8 L	10.2340	10.2320	43 L / 8 L	10.2356	10.2346	16 L / 7 T	10.2356	10.2343	19 L / 7 T
280	11.0236	11.0222	11.0214	11.0202		11.0214	11.0194		11.0230	11.0220		11.0230	11.0217	
300	11.8110	11.8096	11.8088	11.8076		11.8088	11.8068		11.8104	11.8094		11.8104	11.8091	

BEARING BORE DIAMETER					SHAFT DIAMETER / RESULTING FIT (0.0001")									
mm	in		f6		RESULTING FIT	f7		RESULTING FIT	g5		RESULTING FIT	g6		RESULTING FIT
	Shaft	max	min	max		min	max		min	max		min	max	
320	12.5984	12.5969	12.5960	12.5946	39 L / 9 L	12.5960	12.5937	47 L / 9 L	12.5977	12.5967	17 L / 9 T	12.5977	12.5963	21 L / 9 T
340	13.3858	13.3843	13.3834	13.3820		13.3834	13.3811		13.3851	13.3841		13.3851	13.3837	
360	14.1732	14.1717	14.1708	14.1694		14.1708	14.1685		14.1725	14.1715		14.1725	14.1711	
380	14.9606	14.9591	14.9582	14.9568		14.9582	14.9559		14.9599	14.9589		14.9599	14.9585	
400	15.7480	15.7465	15.7456	15.7442		15.7456	15.7433		15.7473	15.7463		15.7473	15.7459	
420	16.5354	16.5337	16.5328	16.5312	43 L / 9 L	16.5328	16.5303	52 L / 9 L	16.5346	16.5336	19 L / 10 T	16.5346	16.5331	24 L / 10 T
440	17.3228	17.3211	17.3202	17.3186		17.3202	17.3177		17.3220	17.3210		17.3220	17.3205	
460	18.1102	18.1085	18.1076	18.1060		18.1076	18.1051		18.1094	18.1084		18.1094	18.1079	
480	18.8976	18.8959	18.8950	18.8934		18.8950	18.8925		18.8969	18.8958		18.8969	18.8953	
500	19.6850	19.6833	19.6824	19.6808		19.6824	19.6799		19.6843	19.6832		19.6843	19.6827	
530	20.8661	20.8642	20.8631	20.8614	47 L / 10 L	20.8631	20.8604	57 L / 10 L	20.8653	20.8642	20 L / 11 T	20.8653	20.8635	26 L / 11 T
560	22.0472	22.0453	22.0443	22.0425		22.0443	22.0415		22.0464	22.0453		22.0464	22.0446	
600	23.6220	23.6201	23.6191	23.6173		23.6191	23.6163		23.6212	23.6201		23.6212	23.6194	
630	24.8031	24.8012	24.8002	24.7984		24.8002	24.7974		24.8023	24.8012		24.8023	24.8006	
670	26.3780	26.3750	26.3748	26.3728		51 L / 2 L	26.3748		26.3717	63 L / 2 L		26.3770	26.3757	
710	27.9528	27.9498	27.9496	27.9476	27.9496		27.9465	27.9518	27.9506		27.9518	27.9498		
750	29.5276	29.5246	29.5244	29.5224	29.5244		29.5213	29.5266	29.5254		29.5266	29.5246		
800	31.4961	31.4931	31.4929	31.4909	31.4929		31.4898	31.4951	31.4939		31.4951	31.4931		
850	33.4646	33.4606	33.4612	33.4590	56 L / 6 T		33.4612	33.4576	69 L / 6 T		33.4635	33.4621	24 L / 29 T	33.4635
900	35.4331	35.4291	35.4297	35.4275		35.4297	35.4261	35.4320		35.4306	35.4320	35.4298		
950	37.4016	37.3976	37.3982	37.3960		37.3982	37.3946	37.4006		37.3991	37.4006	37.3983		
1000	39.3701	39.3661	39.3667	39.3645		39.3667	39.3631	39.3691		39.3676	39.3691	39.3669		
1060	41.7323	41.7274	41.7284	41.7258		65 L / 11 T	41.7284	41.7243		80 L / 11 T	41.7312	41.7295		28 L / 38 T
1120	44.0945	44.0896	44.0906	44.0880	44.0906		44.0865	44.0934	44.0917		44.0934	44.0908		
1180	46.4567	46.4518	46.4528	46.4502	46.4528		46.4487	46.4556	46.4539		46.4556	46.4530		
1250	49.2126	49.2077	49.2087	49.2061	49.2087		49.2046	49.2115	49.2098		49.2115	49.2089		

SHAFT BEARING-SEAT DIAMETERS

Table 12 - Shaft Diameters and Resulting Fits

Units: inch

BEARING BORE DIAMETER			SHAFT DIAMETER / RESULTING FIT (0.0001")													
mm	in		h5		RESULTING FIT	h6		RESULTING FIT	h7		RESULTING FIT	h8		RESULTING FIT		
Shaft	max	min	max	min		max	min		max	min		max	min			
4	0.1575	0.1572	0.1575	0.1573	2 L / 3 T	0.1575	0.1572	3 L / 3 T	0.1575	0.1570	5 L / 3 T	0.1575	0.1568	7 L / 3 T		
5	0.1969	0.1965	0.1969	0.1967		0.1969	0.1965		0.1969	0.1964		0.1969	0.1964		0.1969	0.1961
6	0.2362	0.2359	0.2362	0.2360		0.2362	0.2359		0.2362	0.2357		0.2362	0.2357		0.2362	0.2355
7	0.2756	0.2753	0.2756	0.2754	2 L / 3 T	0.2756	0.2752	4 L / 3 T	0.2756	0.2750	6 L / 3 T	0.2756	0.2747	9 L / 3 T		
8	0.3150	0.3146	0.3150	0.3147		0.3150	0.3146		0.3150	0.3144		0.3150	0.3144		0.3150	0.3141
9	0.3543	0.3540	0.3543	0.3541		0.3543	0.3540		0.3543	0.3537		0.3543	0.3537		0.3543	0.3535
10	0.3937	0.3934	0.3937	0.3935		0.3937	0.3933		0.3937	0.3931		0.3937	0.3931		0.3937	0.3928
12	0.4724	0.4721	0.4724	0.4721	3 L / 3 T	0.4724	0.4720	4 L / 3 T	0.4724	0.4717	7 L / 3 T	0.4724	0.4714	11 L / 3 T		
15	0.5906	0.5902	0.5906	0.5902		0.5906	0.5901		0.5906	0.5898		0.5906	0.5898		0.5906	0.5895
17	0.6693	0.6690	0.6693	0.6690		0.6693	0.6689		0.6693	0.6686		0.6693	0.6686		0.6693	0.6682
20	0.7874	0.7870	0.7874	0.7870	4 L / 4 T	0.7874	0.7869	5 L / 4 T	0.7874	0.7866	8 L / 4 T	0.7874	0.7861	13 L / 4 T		
25	0.9843	0.9839	0.9843	0.9839		0.9843	0.9837		0.9843	0.9834		0.9843	0.9834		0.9843	0.9830
30	1.1811	1.1807	1.1811	1.1807	4 L / 5 T	1.1811	1.1806	6 L / 5 T	1.1811	1.1803	10 L / 5 T	1.1811	1.1798	15 L / 5 T		
35	1.3780	1.3775	1.3780	1.3775		1.3780	1.3773		1.3780	1.3770		1.3780	1.3770		1.3780	1.3764
40	1.5748	1.5743	1.5748	1.5744		1.5748	1.5742		1.5748	1.5738		1.5748	1.5738		1.5748	1.5733
45	1.7717	1.7712	1.7717	1.7712		1.7717	1.7710		1.7717	1.7707		1.7717	1.7707		1.7717	1.7701
50	1.9685	1.9680	1.9685	1.9681	5 L / 6 T	1.9685	1.9679	7 L / 6 T	1.9685	1.9675	12 L / 6 T	1.9685	1.9670	18 L / 6 T		
55	2.1654	2.1648	2.1654	2.1648		2.1654	2.1646		2.1654	2.1642		2.1654	2.1642		2.1654	2.1635
60	2.3622	2.3616	2.3622	2.3617		2.3622	2.3615		2.3622	2.3610		2.3622	2.3610		2.3622	2.3604
65	2.5591	2.5585	2.5591	2.5585		2.5591	2.5583		2.5591	2.5579		2.5591	2.5579		2.5591	2.5572
70	2.7559	2.7553	2.7559	2.7554		2.7559	2.7552		2.7559	2.7547		2.7559	2.7547		2.7559	2.7541
75	2.9528	2.9522	2.9528	2.9522		2.9528	2.9520		2.9528	2.9516		2.9528	2.9516		2.9528	2.9509
80	3.1496	3.1490	3.1496	3.1491	6 L / 8 T	3.1496	3.1489	9 L / 8 T	3.1496	3.1484	14 L / 8 T	3.1496	3.1478	21 L / 8 T		
85	3.3465	3.3457	3.3465	3.3459		3.3465	3.3456		3.3465	3.3451		3.3465	3.3451		3.3465	3.3443
90	3.5433	3.5425	3.5433	3.5427		3.5433	3.5424		3.5433	3.5419		3.5433	3.5419		3.5433	3.5412
95	3.7402	3.7394	3.7402	3.7396		3.7402	3.7393		3.7402	3.7388		3.7402	3.7388		3.7402	3.7380
100	3.9370	3.9362	3.9370	3.9364		3.9370	3.9361		3.9370	3.9356		3.9370	3.9356		3.9370	3.9349
105	4.1339	4.1331	4.1339	4.1333		4.1339	4.1330		4.1339	4.1325		4.1339	4.1325		4.1339	4.1317
110	4.3307	4.3299	4.3307	4.3301	7 L / 10 T	4.3307	4.3298	10 L / 10 T	4.3307	4.3293	16 L / 10 T	4.3307	4.3286	25 L / 10 T		
120	4.7244	4.7236	4.7244	4.7238		4.7244	4.7235		4.7244	4.7230		4.7244	4.7230		4.7244	4.7223
130	5.1181	5.1171	5.1181	5.1174		5.1181	5.1171		5.1181	5.1165		5.1181	5.1165		5.1181	5.1156
140	5.5118	5.5108	5.5118	5.5111		5.5118	5.5108		5.5118	5.5102		5.5118	5.5102		5.5118	5.5093
150	5.9055	5.9045	5.9055	5.9048		5.9055	5.9045		5.9055	5.9039		5.9055	5.9039		5.9055	5.9030
160	6.2992	6.2982	6.2992	6.2985		6.2992	6.2982		6.2992	6.2976		6.2992	6.2976		6.2992	6.2967
170	6.6929	6.6919	6.6929	6.6922	8 L / 12 T	6.6929	6.6919	11 L / 12 T	6.6929	6.6913	18 L / 12 T	6.6929	6.6904	28 L / 12 T		
180	7.0866	7.0856	7.0866	7.0859		7.0866	7.0856		7.0866	7.0850		7.0866	7.0850		7.0866	7.0841
190	7.4803	7.4791	7.4803	7.4795		7.4803	7.4792		7.4803	7.4785		7.4803	7.4785		7.4803	7.4775
200	7.8740	7.8728	7.8740	7.8732		7.8740	7.8729		7.8740	7.8722		7.8740	7.8722		7.8740	7.8712
220	8.6614	8.6602	8.6614	8.6606		8.6614	8.6603		8.6614	8.6596		8.6614	8.6596		8.6614	8.6586
240	9.4488	9.4476	9.4488	9.4480		9.4488	9.4477		9.4488	9.4470		9.4488	9.4470		9.4488	9.4460
260	10.2362	10.2348	10.2362	10.2353	9 L / 14 T	10.2362	10.2350	13 L / 14 T	10.2362	10.2342	20 L / 14 T	10.2362	10.2330	32 L / 14 T		
280	11.0236	11.0222	11.0236	11.0227		11.0236	11.0224		11.0236	11.0216		11.0236	11.0216		11.0236	11.0204
300	11.8110	11.8096	11.8110	11.8101		11.8110	11.8098		11.8110	11.8090		11.8110	11.8090		11.8110	11.8078

BEARING BORE DIAMETER					SHAFT DIAMETER / RESULTING FIT (0.0001")									
mm	in		h5		RESULTING FIT	h6		RESULTING FIT	h7		RESULTING FIT	h8		RESULTING FIT
	Shaft	max	min	max		min	max		min	max		min	max	
320	12.5984	12.5969	12.5984	12.5974	10 L / 16 T	12.5984	12.5970	14 L / 16 T	12.5984	12.5962	22 L / 16 T	12.5984	12.5949	35 L / 16 T
340	13.3858	13.3843	13.3858	13.3848		13.3858	13.3844		13.3858	13.3836		13.3858	13.3823	
360	14.1732	14.1717	14.1732	14.1722		14.1732	14.1718		14.1732	14.1710		14.1732	14.1697	
380	14.9606	14.9591	14.9606	14.9596		14.9606	14.9592		14.9606	14.9584		14.9606	14.9571	
400	15.7480	15.7465	15.7480	15.7470		15.7480	15.7466		15.7480	15.7458		15.7480	15.7445	
420	16.5354	16.5337	16.5354	16.5344	11 L / 18 T	16.5354	16.5339	16 L / 18 T	16.5354	16.5330	25 L / 18 T	16.5354	16.5316	38 L / 18 T
440	17.3228	17.3211	17.3228	17.3218		17.3228	17.3213		17.3228	17.3204		17.3228	17.3190	
460	18.1102	18.1085	18.1102	18.1092		18.1102	18.1087		18.1102	18.1078		18.1102	18.1064	
480	18.8976	18.8959	18.8976	18.8966		18.8976	18.8961		18.8976	18.8952		18.8976	18.8938	
500	19.6850	19.6833	19.6850	19.6840		19.6850	19.6835		19.6850	19.6826		19.6850	19.6812	
530	20.8661	20.8642	20.8661	20.8650	11 L / 20 T	20.8661	20.8644	17 L / 20 T	20.8661	20.8634	28 L / 20 T	20.8661	20.8618	43 L / 20 T
560	22.0472	22.0453	22.0472	22.0461		22.0472	22.0455		22.0472	22.0445		22.0472	22.0429	
600	23.6220	23.6201	23.6220	23.6209		23.6220	23.6203		23.6220	23.6193		23.6220	23.6177	
630	24.8031	24.8012	24.8031	24.8020		24.8031	24.8014		24.8031	24.8004		24.8031	24.7988	
670	26.3780	26.3750	26.3780	26.3767		13 L / 30 T	26.3780		26.3760	20 L / 30 T		26.3780	26.3748	
710	27.9528	27.9498	27.9528	27.9515	27.9528		27.9508	27.9528	27.9496		27.9528	27.9478		
750	29.5276	29.5246	29.5276	29.5263	29.5276		29.5256	29.5276	29.5244		29.5276	29.5226		
800	31.4961	31.4931	31.4961	31.4948	31.4961		31.4941	31.4961	31.4929		31.4961	31.4911		
850	33.4646	33.4606	33.4646	33.4631	14 L / 39 T		33.4646	33.4624	22 L / 39 T		33.4646	33.4610	35 L / 39 T	33.4646
900	35.4331	35.4291	35.4331	35.4317		35.4331	35.4309	35.4331		35.4295	35.4331	35.4276		
950	37.4016	37.3976	37.4016	37.4002		37.4016	37.3994	37.4016		37.3980	37.4016	37.3961		
1000	39.3701	39.3661	39.3701	39.3687		39.3701	39.3679	39.3701		39.3665	39.3701	39.3646		
1060	41.7323	41.7274	41.7323	41.7306		17 L / 49 T	41.7323	41.7297		26 L / 49 T	41.7323	41.7281		41 L / 49 T
1120	44.0945	44.0896	44.0945	44.0928	44.0945		44.0919	44.0945	44.0904		44.0945	44.0880		
1180	46.4567	46.4518	46.4567	46.4550	46.4567		46.4541	46.4567	46.4526		46.4567	46.4502		
1250	49.2126	49.2077	49.2126	49.2109	49.2126		49.2100	49.2126	49.2085		49.2126	49.2061		

SHAFT BEARING-SEAT DIAMETERS

Table 12 - Shaft Diameters and Resulting Fits

Units: inch

BEARING BORE DIAMETER			SHAFT DIAMETER / RESULTING FIT (0.0001")											
mm	in		h9		RESULTING FIT	h10		RESULTING FIT	j5		RESULTING FIT	j6		RESULTING FIT
Shaft	max	min	max	min		max	min		max	min		max	min	
4	0.1575	0.1572	0.1575	0.1563	12 L / 3 T	0.1575	0.1556	19 L / 3 T	0.1576	0.1574	1 L / 4 T	0.1577	0.1574	1 L / 6 T
5	0.1969	0.1965	0.1969	0.1957		0.1969	0.1950		0.1970	0.1968		0.1971	0.1968	
6	0.2362	0.2359	0.2362	0.2350		0.2362	0.2343		0.2363	0.2361		0.2365	0.2361	
7	0.2756	0.2753	0.2756	0.2742	14 L / 3 T	0.2756	0.2733	23 L / 3 T	0.2757	0.2755	1 L / 5 T	0.2759	0.2755	1 L / 6 T
8	0.3150	0.3146	0.3150	0.3135		0.3150	0.3127		0.3151	0.3149		0.3152	0.3149	
9	0.3543	0.3540	0.3543	0.3529		0.3543	0.3520		0.3545	0.3543		0.3546	0.3543	
10	0.3937	0.3934	0.3937	0.3923		0.3937	0.3914		0.3939	0.3936		0.3940	0.3936	
12	0.4724	0.4721	0.4724	0.4707	17 L / 3 T	0.4724	0.4697	28 L / 3 T	0.4726	0.4723	1 L / 5 T	0.4728	0.4723	1 L / 6 T
15	0.5906	0.5902	0.5906	0.5889		0.5906	0.5878		0.5907	0.5904		0.5909	0.5904	
17	0.6693	0.6690	0.6693	0.6676		0.6693	0.6665		0.6695	0.6692		0.6696	0.6692	
20	0.7874	0.7870	0.7874	0.7854	20 L / 4 T	0.7874	0.7841	33 L / 4 T	0.7876	0.7872	2 L / 6 T	0.7878	0.7872	2 L / 7 T
25	0.9843	0.9839	0.9843	0.9822		0.9843	0.9809		0.9844	0.9841		0.9846	0.9841	
30	1.1811	1.1807	1.1811	1.1791	24 L / 5 T	1.1811	1.1778	39 L / 5 T	1.1813	1.1809	2 L / 7 T	1.1815	1.1809	2 L / 9 T
35	1.3780	1.3775	1.3780	1.3755		1.3780	1.3740		1.3782	1.3778		1.3784	1.3778	
40	1.5748	1.5743	1.5748	1.5724		1.5748	1.5709		1.5750	1.5746		1.5752	1.5746	
45	1.7717	1.7712	1.7717	1.7692		1.7717	1.7677		1.7719	1.7715		1.7721	1.7715	
50	1.9685	1.9680	1.9685	1.9661		1.9685	1.9646		1.9687	1.9683		1.9689	1.9683	
55	2.1654	2.1648	2.1654	2.1624	29 L / 6 T	2.1654	2.1606	47 L / 6 T	2.1656	2.1651	3 L / 8 T	2.1658	2.1651	3 L / 11 T
60	2.3622	2.3616	2.3622	2.3593		2.3622	2.3575		2.3624	2.3619		2.3627	2.3619	
65	2.5591	2.5585	2.5591	2.5561		2.5591	2.5543		2.5593	2.5588		2.5595	2.5588	
70	2.7559	2.7553	2.7559	2.7530		2.7559	2.7512		2.7561	2.7556		2.7564	2.7556	
75	2.9528	2.9522	2.9528	2.9498		2.9528	2.9480		2.9530	2.9525		2.9532	2.9525	
80	3.1496	3.1490	3.1496	3.1467	34 L / 8 T	3.1496	3.1449	55 L / 8 T	3.1498	3.1493	4 L / 10 T	3.1501	3.1493	4 L / 13 T
85	3.3465	3.3457	3.3465	3.3430		3.3465	3.3409		3.3467	3.3461		3.3470	3.3461	
90	3.5433	3.5425	3.5433	3.5399		3.5433	3.5378		3.5435	3.5430		3.5438	3.5430	
95	3.7402	3.7394	3.7402	3.7367		3.7402	3.7346		3.7404	3.7398		3.7407	3.7398	
100	3.9370	3.9362	3.9370	3.9336		3.9370	3.9315		3.9372	3.9367		3.9375	3.9367	
105	4.1339	4.1331	4.1339	4.1304	39 L / 10 T	4.1339	4.1283	63 L / 10 T	4.1341	4.1335	4 L / 13 T	4.1344	4.1335	4 L / 15 T
110	4.3307	4.3299	4.3307	4.3273		4.3307	4.3252		4.3309	4.3304		4.3312	4.3304	
120	4.7244	4.7236	4.7244	4.7210		4.7244	4.7189		4.7246	4.7241		4.7249	4.7241	
130	5.1181	5.1171	5.1181	5.1142		5.1181	5.1118		5.1184	5.1177		5.1187	5.1177	
140	5.5118	5.5108	5.5118	5.5079		5.5118	5.5055		5.5121	5.5114		5.5124	5.5114	
150	5.9055	5.9045	5.9055	5.9016	45 L / 12 T	5.9055	5.8992	73 L / 12 T	5.9058	5.9051	5 L / 15 T	5.9061	5.9051	5 L / 18 T
160	6.2992	6.2982	6.2992	6.2953		6.2992	6.2929		6.2995	6.2988		6.2998	6.2988	
170	6.6929	6.6919	6.6929	6.6890		6.6929	6.6866		6.6932	6.6925		6.6935	6.6925	
180	7.0866	7.0856	7.0866	7.0827		7.0866	7.0803		7.0869	7.0862		7.0872	7.0862	
190	7.4803	7.4791	7.4803	7.4758		7.4803	7.4730		7.4806	7.4798		7.4809	7.4798	
200	7.8740	7.8728	7.8740	7.8695	51 L / 14 T	7.8740	7.8667	83 L / 14 T	7.8743	7.8735	6 L / 17 T	7.8746	7.8735	6 L / 20 T
220	8.6614	8.6602	8.6614	8.6569		8.6614	8.6541		8.6617	8.6609		8.6620	8.6609	
240	9.4488	9.4476	9.4488	9.4443		9.4488	9.4415		9.4491	9.4483		9.4494	9.4483	
260	10.2362	10.2348	10.2362	10.2311		10.2362	10.2280		10.2365	10.2356		10.2369	10.2356	
280	11.0236	11.0222	11.0236	11.0185		11.0236	11.0154		11.0239	11.0230		11.0243	11.0230	
300	11.8110	11.8096	11.8110	11.8059		11.8110	11.8028		11.8113	11.8104		11.8117	11.8104	

BEARING BORE DIAMETER					SHAFT DIAMETER / RESULTING FIT (0.0001")									
mm	in		h9		RESULTING FIT	h10		RESULTING FIT	j5		RESULTING FIT	j6		RESULTING FIT
	Shaft	max	min	max		min	max		min	max		min	max	
320	12.5984	12.5969	12.5984	12.5929	55 L / 16 T	12.5984	12.5894	91 L / 16 T	12.5987	12.5977	7 L / 19 T	12.5991	12.5977	7 L / 23 T
340	13.3858	13.3843	13.3858	13.3803		13.3858	13.3768		13.3861	13.3851		13.3865	13.3851	
360	14.1732	14.1717	14.1732	14.1677		14.1732	14.1642		14.1735	14.1725		14.1739	14.1725	
380	14.9606	14.9591	14.9606	14.9551		14.9606	14.9516		14.9609	14.9599		14.9613	14.9599	
400	15.7480	15.7465	15.7480	15.7425		15.7480	15.7390		15.7483	15.7473		15.7487	15.7473	
420	16.5354	16.5337	16.5354	16.5293	61 L / 18 T	16.5354	16.5256	98 L / 18 T	16.5357	16.5346	8 L / 20 T	16.5362	16.5346	8 L / 26 T
440	17.3228	17.3211	17.3228	17.3167		17.3228	17.3130		17.3231	17.3220		17.3236	17.3220	
460	18.1102	18.1085	18.1102	18.1041		18.1102	18.1004		18.1105	18.1094		18.1110	18.1094	
480	18.8976	18.8959	18.8976	18.8915		18.8976	18.8878		18.8979	18.8969		18.8984	18.8969	
500	19.6850	19.6833	19.6850	19.6789		19.6850	19.6752		19.6853	19.6843		19.6858	19.6843	
530	20.8661	20.8642	20.8661	20.8593	69 L / 20 T	20.8661	20.8551	110 L / 20 T	--	--		20.8670	20.8653	9 L / 28 T
560	22.0472	22.0453	22.0472	22.0404		22.0472	22.0362		--	--		22.0481	22.0464	
600	23.6220	23.6201	23.6220	23.6152		23.6220	23.6110		--	--		23.6229	23.6212	
630	24.8031	24.8012	24.8031	24.7963		24.8031	24.7921		--	--		24.8040	24.8023	
670	26.3780	26.3750	26.3780	26.3701	79 L / 30 T	26.3780	26.3654	126 L / 30 T	--	--		26.3789	26.3770	10 L / 39 T
710	27.9528	27.9498	27.9528	27.9449		27.9528	27.9402		--	--		27.9537	27.9518	
750	29.5276	29.5246	29.5276	29.5197		29.5276	29.5150		--	--		29.5285	29.5266	
800	31.4961	31.4931	31.4961	31.4882		31.4961	31.4835		--	--		31.4970	31.4951	
850	33.4646	33.4606	33.4646	33.4555	91 L / 39 T	33.4646	33.4504	142 L / 39 T	--	--		33.4657	33.4635	11 L / 50 T
900	35.4331	35.4291	35.4331	35.4240		35.4331	35.4189		--	--		35.4342	35.4320	
950	37.4016	37.3976	37.4016	37.3925		37.4016	37.3874		--	--		37.4027	37.4005	
1000	39.3701	39.3661	39.3701	39.3610		39.3701	39.3559		--	--		39.3712	39.3690	
1060	41.7323	41.7274	41.7323	41.7220	102 L / 49 T	41.7323	41.7157	165 L / 49 T	--	--		41.7336	41.7310	13 L / 62 T
1120	44.0945	44.0896	44.0945	44.0843		44.0945	44.0780		--	--		44.0958	44.0932	
1180	46.4567	46.4518	46.4567	46.4465		46.4567	46.4402		--	--		46.4580	46.4554	
1250	49.2126	49.2077	49.2126	49.2024		49.2126	49.1961		--	--		49.2139	49.2113	

SHAFT BEARING-SEAT DIAMETERS

Table 12 - Shaft Diameters and Resulting Fits

Units: inch

BEARING BORE DIAMETER			SHAFT DIAMETER / RESULTING FIT (0.0001")											
mm	in		j7		RESULTING FIT	js4		RESULTING FIT	js5		RESULTING FIT	js6		RESULTING FIT
Shaft	max	min	max	min		max	min		max	min		max	min	
4	0.1575	0.1572	0.1578	0.1573	2 L / 6 T	0.1576	0.1574	1 L / 4 T	0.1576	0.1574	1 L / 4 T	0.1576	0.1573	2 L / 5 T
5	0.1969	0.1965	0.1972	0.1967		0.1969	0.1968		0.1969	0.1968		0.1970	0.1967	
6	0.2362	0.2359	0.2365	0.2361		0.2363	0.2361		0.2363	0.2361		0.2364	0.2361	
7	0.2756	0.2753	0.2760	0.2754	2 L / 7 T	0.2757	0.2755	1 L / 4 T	0.2757	0.2755	1 L / 4 T	0.2758	0.2754	2 L / 5 T
8	0.3150	0.3146	0.3154	0.3148		0.3150	0.3149		0.3151	0.3148		0.3151	0.3148	
9	0.3543	0.3540	0.3547	0.3541		0.3544	0.3543		0.3544	0.3542		0.3545	0.3542	
10	0.3937	0.3934	0.3941	0.3935		0.3938	0.3936		0.3938	0.3936		0.3939	0.3935	
12	0.4724	0.4721	0.4729	0.4722	2 L / 8 T	0.4725	0.4723	1 L / 4 T	0.4726	0.4723	2 L / 5 T	0.4727	0.4722	2 L / 5 T
15	0.5906	0.5902	0.5910	0.5903		0.5906	0.5905		0.5907	0.5904		0.5908	0.5903	
17	0.6693	0.6690	0.6698	0.6691		0.6694	0.6692		0.6694	0.6691		0.6695	0.6691	
20	0.7874	0.7870	0.7879	0.7871	3 L / 9 T	0.7875	0.7873	1 L / 5 T	0.7876	0.7872	2 L / 6 T	0.7877	0.7871	3 L / 6 T
25	0.9843	0.9839	0.9848	0.9839		0.9844	0.9841		0.9844	0.9841		0.9845	0.9840	
30	1.1811	1.1807	1.1816	1.1808		1.1812	1.1810		1.1813	1.1809		1.1814	1.1808	
35	1.3780	1.3775	1.3785	1.3776	4 L / 11 T	1.3781	1.3778	1 L / 6 T	1.3782	1.3777	2 L / 7 T	1.3783	1.3776	3 L / 8 T
40	1.5748	1.5743	1.5754	1.5744		1.5749	1.5747		1.5750	1.5746		1.5751	1.5745	
45	1.7717	1.7712	1.7722	1.7713		1.7718	1.7715		1.7719	1.7714		1.7720	1.7713	
50	1.9685	1.9680	1.9691	1.9681		1.9686	1.9684		1.9687	1.9683		1.9688	1.9682	
55	2.1654	2.1648	2.1661	2.1649	5 L / 13 T	2.1655	2.1652	2 L / 7 T	2.1656	2.1651	3 L / 8 T	2.1657	2.1650	4 L / 10 T
60	2.3622	2.3616	2.3629	2.3617		2.3624	2.3620		2.3625	2.3619		2.3626	2.3618	
65	2.5591	2.5585	2.5598	2.5586		2.5592	2.5589		2.5593	2.5588		2.5594	2.5587	
70	2.7559	2.7553	2.7566	2.7554		2.7561	2.7557		2.7562	2.7556		2.7563	2.7555	
75	2.9528	2.9522	2.9535	2.9523		2.9529	2.9526		2.9530	2.9525		2.9531	2.9524	
80	3.1496	3.1490	3.1503	3.1491	3.1498	3.1494	3.1499	3.1494	3.1500	3.1492				
85	3.3465	3.3457	3.3472	3.3459	6 L / 16 T	3.3467	3.3463	2 L / 10 T	3.3468	3.3462	3 L / 11 T	3.3469	3.3460	4 L / 12 T
90	3.5433	3.5425	3.5441	3.5427		3.5435	3.5431		3.5436	3.5430		3.5437	3.5429	
95	3.7402	3.7394	3.7409	3.7396		3.7404	3.7400		3.7405	3.7399		3.7406	3.7397	
100	3.9370	3.9362	3.9378	3.9364		3.9372	3.9368		3.9373	3.9367		3.9374	3.9366	
105	4.1339	4.1331	4.1346	4.1333		4.1341	4.1337		4.1342	4.1336		4.1343	4.1334	
110	4.3307	4.3299	4.3315	4.3301		4.3309	4.3305		4.3310	4.3304		4.3311	4.3303	
120	4.7244	4.7236	4.7252	4.7238	4.7246	4.7242	4.7247	4.7241	4.7248	4.7240				
130	5.1181	5.1171	5.1190	5.1174	7 L / 19 T	5.1183	5.1179	2 L / 12 T	5.1185	5.1178	4 L / 13 T	5.1186	5.1176	5 L / 15 T
140	5.5118	5.5108	5.5127	5.5111		5.5120	5.5116		5.5122	5.5115		5.5123	5.5113	
150	5.9055	5.9045	5.9064	5.9048		5.9057	5.9053		5.9059	5.9052		5.9060	5.9050	
160	6.2992	6.2982	6.3001	6.2985		6.2994	6.2990		6.2996	6.2989		6.2997	6.2987	
170	6.6929	6.6919	6.6938	6.6922		6.6931	6.6927		6.6933	6.6926		6.6934	6.6924	
180	7.0866	7.0856	7.0875	7.0859		7.0869	7.0864		7.0870	7.0863		7.0871	7.0861	
190	7.4803	7.4791	7.4813	7.4795	8 L / 22 T	7.4806	7.4800	3 L / 15 T	7.4807	7.4799	4 L / 16 T	7.4809	7.4797	6 L / 18 T
200	7.8740	7.8728	7.8750	7.8732		7.8743	7.8737		7.8744	7.8736		7.8746	7.8734	
220	8.6614	8.6602	8.6624	8.6606		8.6617	8.6611		8.6618	8.6610		8.6620	8.6608	
240	9.4488	9.4476	9.4498	9.4480		9.4491	9.4485		9.4492	9.4484		9.4494	9.4482	
260	10.2362	10.2348	10.2372	10.2352		10.2365	10.2359		10.2367	10.2358		10.2369	10.2356	
280	11.0236	11.0222	11.0246	11.0226	11.0239	11.0233	11.0241	11.0232	11.0243	11.0230				
300	11.8110	11.8096	11.8120	11.8100	11.8113	11.8107	11.8115	11.8106	11.8117	11.8104				

BEARING BORE DIAMETER					SHAFT DIAMETER / RESULTING FIT (0.0001")									
mm	in		j7		RESULTING FIT	js4		RESULTING FIT	js5		RESULTING FIT	js6		RESULTING FIT
	max	min	max	min		max	min		max	min		max	min	
320	12.5984	12.5969	12.5996	12.5973	11 L / 27 T	12.5988	12.5981	4 L / 19 T	12.5989	12.5979	5 L / 21 T	12.5991	12.5977	7 L / 23 T
340	13.3858	13.3843	13.3870	13.3847		13.3862	13.3855		13.3863	13.3853		13.3865	13.3851	
360	14.1732	14.1717	14.1744	14.1721		14.1736	14.1729		14.1737	14.1727		14.1739	14.1725	
380	14.9606	14.9591	14.9618	14.9595		14.9610	14.9603		14.9611	14.9601		14.9613	14.9599	
400	15.7480	15.7465	15.7492	15.7469		15.7484	15.7477		15.7485	15.7475		15.7487	15.7473	
420	16.5354	16.5337	16.5367	16.5342	13 L / 30 T	16.5358	16.5350	4 L / 22 T	16.5360	16.5349	5 L / 23 T	16.5362	16.5346	8 L / 26 T
440	17.3228	17.3211	17.3241	17.3216		17.3232	17.3224		17.3234	17.3223		17.3236	17.3220	
460	18.1102	18.1085	18.1115	18.1090		18.1106	18.1098		18.1108	18.1097		18.1110	18.1094	
480	18.8976	18.8959	18.8989	18.8964		18.8980	18.8972		18.8982	18.8971		18.8984	18.8969	
500	19.6850	19.6833	19.6863	19.6838		19.6854	19.6846		19.6856	19.6845		19.6858	19.6843	
530	20.8661	20.8642	--	--		--	--		20.8667	20.8656	6 L / 25 T	20.8670	20.8653	9 L / 28 T
560	22.0472	22.0453	--	--		--	--		22.0478	22.0467		22.0481	22.0464	
600	23.6220	23.6201	--	--		--	--		23.6226	23.6215		23.6229	23.6212	
630	24.8031	24.8012	--	--		--	--		24.8037	24.8026		24.8040	24.8023	
670	26.3780	26.3750	--	--		--	--		26.3786	26.3773		26.3789	26.3770	
710	27.9528	27.9498	--	--		--	--		27.9534	27.9521	6 L / 36 T	27.9537	27.9518	10 L / 39 T
750	29.5276	29.5246	--	--		--	--		29.5282	29.5269		29.5285	29.5266	
800	31.4961	31.4931	--	--		--	--		31.4967	31.4954		31.4970	31.4951	
850	33.4646	33.4606	--	--		--	--		33.4653	33.4639		33.4657	33.4635	
900	35.4331	35.4291	--	--		--	--		35.4338	35.4324		35.4342	35.4320	
950	37.4016	37.3976	--	--		--	--		37.4023	37.4009	7 L / 46 T	37.4027	37.4005	11 L / 50 T
1000	39.3701	39.3661	--	--		--	--		39.3708	39.3694		39.3712	39.3690	
1060	41.7323	41.7274	--	--		--	--		41.7331	41.7315		41.7336	41.7310	
1120	44.0945	44.0896	--	--		--	--		44.0953	44.0937		44.0958	44.0932	
1180	46.4567	46.4518	--	--		--	--		46.4575	46.4559		46.4580	46.4554	
1250	49.2126	49.2077	--	--		--	--		49.2134	49.2118	8 L / 57 T	49.2139	49.2113	13 L / 62 T

SHAFT BEARING-SEAT DIAMETERS

Table 12 - Shaft Diameters and Resulting Fits

Units: inch

BEARING BORE DIAMETER			SHAFT DIAMETER / RESULTING FIT (0.0001")											
mm	in		k4		RESULTING FIT	k5		RESULTING FIT	k6		RESULTING FIT	k7		RESULTING FIT
Shaft	max	min	max	min		max	min		max	min		max	min	
4	0.1575	0.1572	0.1577	0.1575	0 T / 5 T	0.1577	0.1575	0 T / 6 T	0.1578	0.1575	0 T / 7 T	0.1580	0.1575	0 T / 8 T
5	0.1969	0.1965	0.1970	0.1969		0.1971	0.1969		0.1972	0.1969		0.1974	0.1969	
6	0.2362	0.2359	0.2364	0.2363		0.2365	0.2363		0.2366	0.2363		0.2367	0.2363	
7	0.2756	0.2753	0.2758	0.2756	0 T / 5 T	0.2759	0.2756	0 T / 6 T	0.2760	0.2756	0 T / 7 T	0.2762	0.2756	0 T / 9 T
8	0.3150	0.3146	0.3152	0.3150		0.3152	0.3150		0.3154	0.3150		0.3156	0.3150	
9	0.3543	0.3540	0.3545	0.3544		0.3546	0.3544		0.3547	0.3544		0.3550	0.3544	
10	0.3937	0.3934	0.3939	0.3937		0.3940	0.3937		0.3941	0.3937		0.3943	0.3937	
12	0.4724	0.4721	0.4727	0.4725	0 T / 6 T	0.4728	0.4725	0 T / 7 T	0.4729	0.4725	0 T / 8 T	0.4732	0.4725	0 T / 11 T
15	0.5906	0.5902	0.5908	0.5906		0.5909	0.5906		0.5910	0.5906		0.5913	0.5906	
17	0.6693	0.6690	0.6695	0.6693		0.6696	0.6693		0.6698	0.6693		0.6700	0.6693	
20	0.7874	0.7870	0.7877	0.7875	1 T / 7 T	0.7878	0.7875	0 T / 8 T	0.7880	0.7875	1 T / 10 T	0.7883	0.7875	1 T / 13 T
25	0.9843	0.9839	0.9846	0.9843		0.9847	0.9843		0.9848	0.9843		0.9852	0.9843	
30	1.1811	1.1807	1.1814	1.1812	1 T / 8 T	1.1815	1.1812	1 T / 10 T	1.1817	1.1812	1 T / 12 T	1.1820	1.1812	1 T / 15 T
35	1.3780	1.3775	1.3783	1.3780		1.3785	1.3780		1.3787	1.3780		1.3790	1.3780	
40	1.5748	1.5743	1.5752	1.5749		1.5753	1.5749		1.5755	1.5749		1.5759	1.5749	
45	1.7717	1.7712	1.7720	1.7717		1.7722	1.7717		1.7724	1.7717		1.7727	1.7717	
50	1.9685	1.9680	1.9689	1.9686		1.9690	1.9686		1.9692	1.9686		1.9696	1.9686	
55	2.1654	2.1648	2.1657	2.1654	1 T / 10 T	2.1659	2.1654	1 T / 12 T	2.1662	2.1654	1 T / 14 T	2.1666	2.1654	1 T / 19 T
60	2.3622	2.3616	2.3626	2.3623		2.3628	2.3623		2.3630	2.3623		2.3635	2.3623	
65	2.5591	2.5585	2.5594	2.5591		2.5596	2.5591		2.5599	2.5591		2.5603	2.5591	
70	2.7559	2.7553	2.7563	2.7560		2.7565	2.7560		2.7567	2.7560		2.7572	2.7560	
75	2.9528	2.9522	2.9531	2.9528		2.9533	2.9528		2.9536	2.9528		2.9540	2.9528	
80	3.1496	3.1490	3.1500	3.1497	3.1502	3.1497	3.1504	3.1497	3.1509	3.1497				
85	3.3465	3.3457	3.3470	3.3466	1 T / 13 T	3.3472	3.3466	1 T / 15 T	3.3474	3.3466	1 T / 18 T	3.3480	3.3466	1 T / 23 T
90	3.5433	3.5425	3.5438	3.5434		3.5440	3.5434		3.5443	3.5434		3.5448	3.5434	
95	3.7402	3.7394	3.7407	3.7403		3.7409	3.7403		3.7411	3.7403		3.7417	3.7403	
100	3.9370	3.9362	3.9375	3.9371		3.9377	3.9371		3.9380	3.9371		3.9385	3.9371	
105	4.1339	4.1331	4.1344	4.1340		4.1346	4.1340		4.1348	4.1340		4.1354	4.1340	
110	4.3307	4.3299	4.3312	4.3308		4.3314	4.3308		4.3317	4.3308		4.3322	4.3308	
120	4.7244	4.7236	4.7249	4.7245	4.7251	4.7245	4.7254	4.7245	4.7259	4.7245				
130	5.1181	5.1171	5.1187	5.1182	1 T / 16 T	5.1189	5.1182	1 T / 18 T	5.1192	5.1182	1 T / 21 T	5.1198	5.1182	1 T / 27 T
140	5.5118	5.5108	5.5124	5.5119		5.5126	5.5119		5.5129	5.5119		5.5135	5.5119	
150	5.9055	5.9045	5.9061	5.9056		5.9063	5.9056		5.9066	5.9056		5.9072	5.9056	
160	6.2992	6.2982	6.2998	6.2993		6.3000	6.2993		6.3003	6.2993		6.3009	6.2993	
170	6.6929	6.6919	6.6935	6.6930		6.6937	6.6930		6.6940	6.6930		6.6946	6.6930	
180	7.0866	7.0856	7.0872	7.0867	7.0874	7.0867	7.0877	7.0867	7.0883	7.0867				
190	7.4803	7.4791	7.4810	7.4805	2 T / 19 T	7.4813	7.4805	2 T / 21 T	7.4816	7.4805	2 T / 25 T	7.4823	7.4805	2 T / 31 T
200	7.8740	7.8728	7.8747	7.8742		7.8750	7.8742		7.8753	7.8742		7.8760	7.8742	
220	8.6614	8.6602	8.6621	8.6616		8.6624	8.6616		8.6627	8.6616		8.6634	8.6616	
240	9.4488	9.4476	9.4495	9.4490		9.4498	9.4490		9.4501	9.4490		9.4508	9.4490	
260	10.2362	10.2348	10.2370	10.2364	2 T / 22 T	10.2373	10.2364	2 T / 24 T	10.2376	10.2364	2 T / 28 T	10.2384	10.2364	2 T / 36 T
280	11.0236	11.0222	11.0244	11.0238		11.0247	11.0238		11.0250	11.0238		11.0258	11.0238	
300	11.8110	11.8096	11.8118	11.8112		11.8121	11.8112		11.8124	11.8112		11.8132	11.8112	

BEARING BORE DIAMETER				SHAFT DIAMETER / RESULTING FIT (0.0001")										
mm	in		k4		RESULTING FIT	k5		RESULTING FIT	k6		RESULTING FIT	k7		RESULTING FIT
	Shaft	max	min	max		min	max		min	max		min	max	
320	12.5984	12.5969	12.5993	12.5986	2 T / 24 T	12.5996	12.5986	2 T / 27 T	12.6000	12.5986	2 T / 31 T	12.6008	12.5986	2 T / 40 T
340	13.3858	13.3843	13.3867	13.3860		13.3870	13.3860		13.3874	13.3860		13.3882	13.3860	
360	14.1732	14.1717	14.1741	14.1734		14.1744	14.1734		14.1748	14.1734		14.1756	14.1734	
380	14.9606	14.9591	14.9615	14.9608		14.9618	14.9608		14.9622	14.9608		14.9630	14.9608	
400	15.7480	15.7465	15.7489	15.7482		15.7492	15.7482		15.7496	15.7482		15.7504	15.7482	
420	16.5354	16.5337	16.5364	16.5356	2 T / 28 T	16.5367	16.5356	2 T / 30 T	16.5372	16.5356	2 T / 35 T	16.5381	16.5356	2 T / 44 T
440	17.3228	17.3211	17.3238	17.3230		17.3241	17.3230		17.3246	17.3230		17.3255	17.3230	
460	18.1102	18.1085	18.1112	18.1104		18.1115	18.1104		18.1120	18.1104		18.1129	18.1104	
480	18.8976	18.8959	18.8986	18.8978		18.8989	18.8978		18.8994	18.8978		18.9003	18.8978	
500	19.6850	19.6833	19.6860	19.6852		19.6863	19.6852		19.6868	19.6852		19.6877	19.6852	
530	20.8661	20.8642	--	--	0 T / 31 T	20.8673	20.8661	0 T / 37 T	20.8679	20.8661	0 T / 37 T	20.8689	20.8661	0 T / 47 T
560	22.0472	22.0453	--	--		22.0484	22.0472		22.0490	22.0472		22.0500	22.0472	
600	23.6220	23.6201	--	--		23.6232	23.6220		23.6238	23.6220		23.6248	23.6220	
630	24.8031	24.8012	--	--		24.8043	24.8031		24.8049	24.8031		24.8059	24.8031	
670	26.3780	26.3750	--	--		26.3792	26.3780		26.3799	26.3780		26.3811	26.3780	
710	27.9528	27.9498	--	--	0 T / 42 T	27.9540	27.9528	0 T / 49 T	27.9547	27.9528	0 T / 49 T	27.9559	27.9528	0 T / 61 T
750	29.5276	29.5246	--	--		29.5288	29.5276		29.5295	29.5276		29.5307	29.5276	
800	31.4961	31.4931	--	--		31.4973	31.4961		31.4980	31.4961		31.4992	31.4961	
850	33.4646	33.4606	--	--		33.4660	33.4646		33.4668	33.4646		33.4681	33.4646	
900	35.4331	35.4291	--	--		35.4345	35.4331		35.4353	35.4331		35.4366	35.4331	
950	37.4016	37.3976	--	--	0 T / 54 T	37.4030	37.4016	0 T / 61 T	37.4038	37.4016	0 T / 61 T	37.4051	37.4016	0 T / 75 T
1000	39.3701	39.3661	--	--		39.3715	39.3701		39.3723	39.3701		39.3736	39.3701	
1060	41.7323	41.7274	--	--		41.7339	41.7323		41.7349	41.7323		41.7364	41.7323	
1120	44.0945	44.0896	--	--		44.0961	44.0945		44.0971	44.0945		44.0986	44.0945	
1180	46.4567	46.4518	--	--		46.4583	46.4567		46.4593	46.4567		46.4608	46.4567	
1250	49.2126	49.2077	--	--	0 T / 66 T	49.2143	49.2126	0 T / 66 T	49.2152	49.2126	0 T / 75 T	49.2167	49.2126	0 T / 91 T

SHAFT BEARING-SEAT DIAMETERS

Table 12 - Shaft Diameters and Resulting Fits

Units: inch

BEARING BORE DIAMETER				SHAFT DIAMETER / RESULTING FIT (0.0001")										
mm	in		m5		RESULTING FIT	m6		RESULTING FIT	n5		RESULTING FIT	n6		RESULTING FIT
Shaft	max	min	max	min		max	min		max	min		max	min	
4	0.1575	0.1572	0.1578	0.1576	2 T / 7 T	0.1580	0.1576	2 T / 8 T	0.1580	0.1578	3 T / 8 T	0.1581	0.1578	3 T / 9 T
5	0.1969	0.1965	0.1972	0.1970		0.1973	0.1970		0.1974	0.1972		0.1975	0.1972	
6	0.2362	0.2359	0.2366	0.2364		0.2367	0.2364		0.2367	0.2365		0.2369	0.2365	
7	0.2756	0.2753	0.2761	0.2758	2 T / 8 T	0.2762	0.2758	2 T / 9 T	0.2762	0.2760	4 T / 9 T	0.2763	0.2760	4 T / 11 T
8	0.3150	0.3146	0.3154	0.3152		0.3156	0.3152		0.3156	0.3154		0.3157	0.3154	
9	0.3543	0.3540	0.3548	0.3546		0.3549	0.3546		0.3550	0.3547		0.3551	0.3547	
10	0.3937	0.3934	0.3942	0.3939		0.3943	0.3939		0.3943	0.3941		0.3944	0.3941	
12	0.4724	0.4721	0.4730	0.4727	3 T / 9 T	0.4731	0.4727	3 T / 10 T	0.4732	0.4729	5 T / 11 T	0.4733	0.4729	5 T / 12 T
15	0.5906	0.5902	0.5911	0.5908		0.5913	0.5908		0.5913	0.5910		0.5915	0.5910	
17	0.6693	0.6690	0.6699	0.6696		0.6700	0.6696		0.6701	0.6698		0.6702	0.6698	
20	0.7874	0.7870	0.7881	0.7877	3 T / 11 T	0.7882	0.7877	3 T / 12 T	0.7883	0.7880	6 T / 13 T	0.7885	0.7880	6 T / 15 T
25	0.9843	0.9839	0.9849	0.9846		0.9851	0.9846		0.9852	0.9848		0.9854	0.9848	
30	1.1811	1.1807	1.1818	1.1814		1.1819	1.1814		1.1820	1.1817		1.1822	1.1817	
35	1.3780	1.3775	1.3787	1.3783	4 T / 13 T	1.3789	1.3783	4 T / 15 T	1.3791	1.3786	7 T / 16 T	1.3793	1.3786	7 T / 18 T
40	1.5748	1.5743	1.5756	1.5752		1.5758	1.5752		1.5759	1.5755		1.5761	1.5755	
45	1.7717	1.7712	1.7724	1.7720		1.7726	1.7720		1.7728	1.7723		1.7730	1.7723	
50	1.9685	1.9680	1.9693	1.9689		1.9695	1.9689		1.9696	1.9692		1.9698	1.9692	
55	2.1654	2.1648	2.1663	2.1658	4 T / 15 T	2.1665	2.1658	4 T / 18 T	2.1667	2.1661	8 T / 19 T	2.1669	2.1661	8 T / 21 T
60	2.3622	2.3616	2.3631	2.3626		2.3634	2.3626		2.3635	2.3630		2.3637	2.3630	
65	2.5591	2.5585	2.5600	2.5595		2.5602	2.5595		2.5604	2.5598		2.5606	2.5598	
70	2.7559	2.7553	2.7569	2.7563		2.7571	2.7563		2.7572	2.7567		2.7574	2.7567	
75	2.9528	2.9522	2.9537	2.9532		2.9539	2.9532		2.9541	2.9535		2.9543	2.9535	
80	3.1496	3.1490	3.1506	3.1500		3.1508	3.1500		3.1509	3.1504		3.1511	3.1504	
85	3.3465	3.3457	3.3476	3.3470	5 T / 19 T	3.3478	3.3470	5 T / 22 T	3.3480	3.3474	9 T / 23 T	3.3482	3.3474	9 T / 26 T
90	3.5433	3.5425	3.5444	3.5438		3.5447	3.5438		3.5448	3.5442		3.5451	3.5442	
95	3.7402	3.7394	3.7413	3.7407		3.7415	3.7407		3.7417	3.7411		3.7419	3.7411	
100	3.9370	3.9362	3.9381	3.9375		3.9384	3.9375		3.9385	3.9379		3.9388	3.9379	
105	4.1339	4.1331	4.1350	4.1344		4.1352	4.1344		4.1354	4.1348		4.1356	4.1348	
110	4.3307	4.3299	4.3318	4.3312		4.3321	4.3312		4.3322	4.3316		4.3325	4.3316	
120	4.7244	4.7236	4.7255	4.7249	6 T / 23 T	4.7258	4.7249	6 T / 26 T	4.7259	4.7253	11 T / 28 T	4.7262	4.7253	11 T / 30 T
130	5.1181	5.1171	5.1194	5.1187		5.1197	5.1187		5.1199	5.1192		5.1202	5.1192	
140	5.5118	5.5108	5.5131	5.5124		5.5134	5.5124		5.5136	5.5129		5.5139	5.5129	
150	5.9055	5.9045	5.9068	5.9061		5.9071	5.9061		5.9073	5.9066		5.9076	5.9066	
160	6.2992	6.2982	6.3005	6.2998		6.3008	6.2998		6.3010	6.3003		6.3013	6.3003	
170	6.6929	6.6919	6.6942	6.6935		6.6945	6.6935		6.6947	6.6940		6.6950	6.6940	
180	7.0866	7.0856	7.0879	7.0872	7 T / 26 T	7.0882	7.0872	7 T / 30 T	7.0884	7.0877	12 T / 32 T	7.0887	7.0877	12 T / 35 T
190	7.4803	7.4791	7.4818	7.4810		7.4821	7.4810		7.4823	7.4815		7.4827	7.4815	
200	7.8740	7.8728	7.8755	7.8747		7.8758	7.8747		7.8760	7.8752		7.8764	7.8752	
220	8.6614	8.6602	8.6629	8.6621		8.6632	8.6621		8.6634	8.6626		8.6638	8.6626	
240	9.4488	9.4476	9.4503	9.4495		9.4506	9.4495		9.4508	9.4500		9.4512	9.4500	
260	10.2362	10.2348	10.2379	10.2370		8 T / 31 T	10.2383		10.2370	8 T / 34 T		10.2385	10.2376	
280	11.0236	11.0222	11.0253	11.0244	11.0257		11.0244	11.0259	11.0250		11.0262	11.0250		
300	11.8110	11.8096	11.8127	11.8118	11.8131		11.8118	11.8133	11.8124		11.8136	11.8124		

BEARING BORE DIAMETER					SHAFT DIAMETER / RESULTING FIT (0.0001")									
mm	in		m5		RESULTING FIT	m6		RESULTING FIT	n5		RESULTING FIT	n6		RESULTING FIT
	Shaft	max	min	max		min	max		min	max		min	max	
320	12.5984	12.5969	12.6002	12.5993	8 / 34 T	12.6007	12.5993	8 T / 38 T	12.6009	12.5999	15 T / 40 T	12.6013	12.5999	15 T / 44 T
340	13.3858	13.3843	13.3876	13.3867		13.3881	13.3867		13.3883	13.3873		13.3887	13.3873	
360	14.1732	14.1717	14.1750	14.1741		14.1755	14.1741		14.1757	14.1747		14.1761	14.1747	
380	14.9606	14.9591	14.9624	14.9615		14.9629	14.9615		14.9631	14.9621		14.9635	14.9621	
400	15.7480	15.7465	15.7498	15.7489		15.7503	15.7489		15.7505	15.7495		15.7509	15.7495	
420	16.5354	16.5337	16.5374	16.5363	9 T / 37 T	16.5379	16.5363	9 T / 43 T	16.5381	16.5370	16 T / 44 T	16.5386	16.5370	16 T / 49 T
440	17.3228	17.3211	17.3248	17.3237		17.3253	17.3237		17.3255	17.3244		17.3260	17.3244	
460	18.1102	18.1085	18.1122	18.1111		18.1127	18.1111		18.1129	18.1118		18.1134	18.1118	
480	18.8976	18.8959	18.8996	18.8985		18.9001	18.8985		18.9003	18.8992		18.9008	18.8992	
500	19.6850	19.6833	19.6870	19.6859		19.6875	19.6859		19.6877	19.6866		19.6882	19.6866	
530	20.8661	20.8642	20.8683	20.8672	10 T / 41 T	20.8689	20.8672	10 T / 47 T	20.8690	20.8679	17 T / 48 T	20.8696	20.8679	17 T / 54 T
560	22.0472	22.0453	22.0494	22.0483		22.0500	22.0483		22.0501	22.0490		22.0507	22.0490	
600	23.6220	23.6201	23.6242	23.6231		23.6248	23.6231		23.6249	23.6238		23.6255	23.6238	
630	24.8031	24.8012	24.8053	24.8042		24.8059	24.8042		24.8060	24.8049		24.8066	24.8049	
670	26.3780	26.3750	26.3804	26.3791	12 T / 54 T	26.3811	26.3791	12 T / 61 T	26.3812	26.3799	20 T / 62 T	26.3819	26.3799	20 T / 69 T
710	27.9528	27.9498	27.9552	27.9539		27.9559	27.9539		27.9560	27.9547		27.9567	27.9547	
750	29.5276	29.5246	29.5300	29.5287		29.5307	29.5287		29.5308	29.5295		29.5315	29.5295	
800	31.4961	31.4931	31.4985	31.4972		31.4992	31.4972		31.4993	31.4980		31.5000	31.4980	
850	33.4646	33.4606	33.4673	33.4659	13 T / 67 T	33.4681	33.4659	13 T / 75 T	33.4682	33.4668	22 T / 76 T	33.4690	33.4668	22 T / 83 T
900	35.4331	35.4291	35.4358	35.4344		35.4366	35.4344		35.4367	35.4353		35.4375	35.4353	
950	37.4016	37.3976	37.4043	37.4029		37.4051	37.4029		37.4052	37.4038		37.4060	37.4038	
1000	39.3701	39.3661	39.3728	39.3714		39.3736	39.3714		39.3737	39.3723		39.3745	39.3723	
1060	41.7323	41.7274	41.7355	41.7339	16 T / 81 T	41.7365	41.7339	16 T / 91 T	41.7365	41.7349	26 T / 92 T	41.7375	41.7349	26 T / 101 T
1120	44.0945	44.0896	44.0977	44.0961		44.0987	44.0961		44.0987	44.0971		44.0997	44.0971	
1180	46.4567	46.4518	46.4599	46.4583		46.4609	46.4583		46.4609	46.4593		46.4619	46.4593	
1250	49.2126	49.2077	49.2158	49.2142		49.2168	49.2142		49.2169	49.2152		49.2178	49.2152	

SHAFT BEARING-SEAT DIAMETERS

Table 12 - Shaft Diameters and Resulting Fits

Units: inch

BEARING BORE DIAMETER			SHAFT DIAMETER / RESULTING FIT (0.0001")								
mm	in		p6		RESULTING FIT	r6		RESULTING FIT	r7		RESULTING FIT
Shaft	max	min	max	min		max	min		max	min	
4	0.1575	0.1572	0.1583	0.1580	5 T / 11 T	0.1584	0.1581	6 T / 12 T	0.1585	0.1581	6 T / 14 T
5	0.1969	0.1965	0.1976	0.1973		0.1978	0.1974		0.1979	0.1974	
6	0.2362	0.2359	0.2370	0.2367		0.2371	0.2368		0.2373	0.2368	
7	0.2756	0.2753	0.2765	0.2762	6 T / 13 T	0.2767	0.2763	7 T / 14 T	0.2769	0.2763	7 T / 17 T
8	0.3150	0.3146	0.3159	0.3156		0.3161	0.3157		0.3163	0.3157	
9	0.3543	0.3540	0.3553	0.3549		0.3554	0.3551		0.3557	0.3551	
10	0.3937	0.3934	0.3946	0.3943	7 T / 15 T	0.3948	0.3944	9 T / 17 T	0.3950	0.3944	9 T / 19 T
12	0.4724	0.4721	0.4736	0.4731		0.4738	0.4733		0.4741	0.4733	
15	0.5906	0.5902	0.5917	0.5913		0.5919	0.5915		0.5922	0.5915	
17	0.6693	0.6690	0.6704	0.6700	9 T / 18 T	0.6706	0.6702	11 T / 20 T	0.6709	0.6702	11 T / 23 T
20	0.7874	0.7870	0.7888	0.7883		0.7890	0.7885		0.7893	0.7885	
25	0.9843	0.9839	0.9856	0.9851		0.9859	0.9854		0.9862	0.9854	
30	1.1811	1.1807	1.1825	1.1820	10 T / 21 T	1.1827	1.1822	13 T / 24 T	1.1830	1.1822	13 T / 28 T
35	1.3780	1.3775	1.3796	1.3790		1.3799	1.3793		1.3803	1.3793	
40	1.5748	1.5743	1.5765	1.5758		1.5768	1.5761		1.5771	1.5761	
45	1.7717	1.7712	1.7733	1.7727	13 T / 26 T	1.7736	1.7730	16 T / 30 T	1.7740	1.7730	16 T / 34 T
50	1.9685	1.9680	1.9702	1.9695		1.9705	1.9698		1.9708	1.9698	
55	2.1654	2.1648	2.1674	2.1666		2.1677	2.1670		2.1681	2.1670	
60	2.3622	2.3616	2.3642	2.3635	15 T / 31 T	2.3646	2.3638	20 T / 37 T	2.3650	2.3638	20 T / 42 T
65	2.5591	2.5585	2.5611	2.5603		2.5614	2.5607		2.5619	2.5607	
70	2.7559	2.7553	2.7579	2.7572		2.7583	2.7576		2.7588	2.7576	
75	2.9528	2.9522	2.9548	2.9540	17 T / 37 T	2.9552	2.9544	25 T / 44 T	2.9556	2.9544	25 T / 50 T
80	3.1496	3.1490	3.1516	3.1509		3.1520	3.1513		3.1525	3.1513	
85	3.3465	3.3457	3.3488	3.3479		3.3493	3.3485		3.3498	3.3485	
90	3.5433	3.5425	3.5456	3.5448	20 T / 43 T	3.5462	3.5453	30 T / 54 T	3.5467	3.5453	30 T / 60 T
95	3.7402	3.7394	3.7425	3.7416		3.7430	3.7422		3.7435	3.7422	
100	3.9370	3.9362	3.9393	3.9385		3.9399	3.9390		3.9404	3.9390	
105	4.1339	4.1331	4.1362	4.1353	22 T / 48 T	4.1369	4.1360	37 T / 63 T	4.1374	4.1360	37 T / 71 T
110	4.3307	4.3299	4.3330	4.3322		4.3337	4.3328		4.3342	4.3328	
120	4.7244	4.7236	4.7267	4.7259		4.7274	4.7265		4.7279	4.7265	
130	5.1181	5.1171	5.1208	5.1198	20 T / 48 T	5.1216	5.1206	25 T / 44 T	5.1222	5.1206	25 T / 50 T
140	5.5118	5.5108	5.5145	5.5135		5.5153	5.5143		5.5159	5.5143	
150	5.9055	5.9045	5.9082	5.9072		5.9091	5.9081		5.9096	5.9081	
160	6.2992	6.2982	6.3019	6.3009	20 T / 43 T	6.3028	6.3018	30 T / 54 T	6.3033	6.3018	30 T / 60 T
170	6.6929	6.6919	6.6956	6.6946		6.6966	6.6956		6.6972	6.6956	
180	7.0866	7.0856	7.0893	7.0883		7.0903	7.0893		7.0909	7.0893	
190	7.4803	7.4791	7.4834	7.4823	22 T / 48 T	7.4845	7.4833	37 T / 63 T	7.4852	7.4833	37 T / 71 T
200	7.8740	7.8728	7.8771	7.8760		7.8782	7.8770		7.8789	7.8770	
220	8.6614	8.6602	8.6645	8.6634		8.6657	8.6646		8.6664	8.6646	
240	9.4488	9.4476	9.4519	9.4508	22 T / 48 T	9.4533	9.4521	37 T / 63 T	9.4539	9.4521	37 T / 71 T
260	10.2362	10.2348	10.2397	10.2384		10.2412	10.2399		10.2420	10.2399	
280	11.0236	11.0222	11.0271	11.0258		11.0286	11.0273		11.0294	11.0273	
300	11.8110	11.8096	11.8145	11.8132	11.8161	11.8149	11.8169	11.8149			

BEARING BORE DIAMETER				SHAFT DIAMETER / RESULTING FIT (0.0001")							
mm	in		p6		RESULTING FIT	r6		RESULTING FIT	r7		RESULTING FIT
	max	min	max	min		max	min		max	min	
320	12.5984	12.5969	12.6023	12.6009	24 T / 54 T	12.6041	12.6027	43 T / 72 T	12.6049	12.6027	43 T / 81 T
340	13.3858	13.3843	13.3897	13.3883		13.3915	13.3901		13.3923	13.3901	
360	14.1732	14.1717	14.1771	14.1757		14.1791	14.1777		14.1800	14.1777	
380	14.9606	14.9591	14.9645	14.9631		14.9665	14.9651		14.9674	14.9651	
400	15.7480	15.7465	15.7519	15.7505		15.7539	15.7525		15.7548	15.7525	
420	16.5354	16.5337	16.5397	16.5381	27 T / 60 T	16.5420	16.5404	50 T / 83 T	16.5429	16.5404	50 T / 92 T
440	17.3228	17.3211	17.3271	17.3255		17.3294	17.3278		17.3303	17.3278	
460	18.1102	18.1085	18.1145	18.1129		18.1170	18.1154		18.1179	18.1154	
480	18.8976	18.8959	18.9019	18.9003		18.9044	18.9028		18.9053	18.9028	
500	19.6850	19.6833	19.6893	19.6877		19.6918	19.6902		19.6927	19.6902	
530	20.8661	20.8642	20.8709	20.8692	31 T / 68 T	20.8738	20.8720	59 T / 96 T	20.8748	20.8720	59 T / 106 T
560	22.0472	22.0453	22.0520	22.0503		22.0549	22.0531		22.0559	22.0531	
600	23.6220	23.6201	23.6269	23.6251		23.6299	23.6281		23.6309	23.6281	
630	24.8031	24.8012	24.8080	24.8062		24.8110	24.8093		24.8120	24.8093	
670	26.3780	26.3750	26.3834	26.3814	35 T / 84 T	26.3868	26.3848	69 T / 118 T	26.3880	26.3848	69 T / 130 T
710	27.9528	27.9498	27.9582	27.9562		27.9616	27.9596		27.9628	27.9596	
750	29.5276	29.5246	29.5330	29.5310		29.5368	29.5348		29.5380	29.5348	
800	31.4961	31.4931	31.5015	31.4995		31.5053	31.5033		31.5065	31.5033	
850	33.4646	33.4606	33.4707	33.4685	39 T / 101 T	33.4750	33.4728	83 T / 144 T	33.4764	33.4728	83 T / 157 T
900	35.4331	35.4291	35.4392	35.4370		35.4435	35.4413		35.4449	35.4413	
950	37.4016	37.3976	37.4077	37.4055		37.4124	37.4102		37.4138	37.4102	
1000	39.3701	39.3661	39.3762	39.3740		39.3809	39.3787		39.3823	39.3787	
1060	41.7323	41.7274	41.7396	41.7370	47 T / 122 T	41.7447	41.7421	98 T / 174 T	41.7463	41.7421	98 T / 189 T
1120	44.0945	44.0896	44.1018	44.0992		44.1069	44.1043		44.1085	44.1043	
1180	46.4567	46.4518	46.4640	46.4614		46.4695	46.4669		46.4711	46.4669	
1250	49.2126	49.2077	49.2199	49.2173		49.2254	49.2228		49.2270	49.2228	

HOUSING BEARING-SEAT DIAMETERS

Table 13 - Housing Bore Diameters and Resulting Fits

Units: inch

BEARING OUTSIDE DIAMETER			HOUSING BORE / RESULTING FIT (0.0001")											
mm	in		F7		RESULTING FIT	G6		RESULTING FIT	G7		RESULTING FIT	H6		RESULTING FIT
O.D.	max	min	max	min		max	min		max	min		max	min	
16	0.6299	0.6296	0.6313	0.6306	17 L / 6 L	0.6306	0.6302	10 L / 2 L	0.6309	0.6302	13 L / 2 L	0.6304	0.6299	7 L / 0 T
19	0.7480	0.7477	0.7496	0.7488	20 L / 8 L	0.7488	0.7483	11 L / 3 L	0.7491	0.7483	15 L / 3 L	0.7485	0.7480	9 L / 0 T
22	0.8661	0.8658	0.8678	0.8669		0.8669	0.8664		0.8672	0.8664		0.8667	0.8661	
24	0.9449	0.9445	0.9465	0.9457		0.9457	0.9452		0.9460	0.9452		0.9454	0.9449	
26	1.0236	1.0233	1.0252	1.0244		1.0244	1.0239		1.0247	1.0239		1.0241	1.0236	
28	1.1024	1.1020	1.1040	1.1031		1.1031	1.1026		1.1035	1.1026		1.1029	1.1024	
30	1.1811	1.1807	1.1827	1.1819	24 L / 10 L	1.1819	1.1814	14 L / 4 L	1.1822	1.1814	18 L / 4 L	1.1816	1.1811	11 L / 0 T
32	1.2598	1.2594	1.2618	1.2608		1.2608	1.2602		1.2612	1.2602		1.2605	1.2598	
35	1.3780	1.3775	1.3799	1.3789		1.3789	1.3783		1.3793	1.3783		1.3786	1.3780	
37	1.4567	1.4563	1.4587	1.4577		1.4577	1.4570		1.4580	1.4570		1.4573	1.4567	
40	1.5748	1.5744	1.5768	1.5758		1.5758	1.5752		1.5761	1.5752		1.5754	1.5748	
42	1.6535	1.6531	1.6555	1.6545		1.6545	1.6539		1.6549	1.6539		1.6542	1.6535	
47	1.8504	1.8500	1.8524	1.8514		1.8514	1.8507		1.8517	1.8507		1.8510	1.8504	
52	2.0472	2.0467	2.0496	2.0484	29 L / 12 L	2.0484	2.0476	17 L / 4 L	2.0488	2.0476	21 L / 4 L	2.0480	2.0472	13 L / 0 T
55	2.1654	2.1648	2.1677	2.1665		2.1665	2.1657		2.1669	2.1657		2.1661	2.1654	
62	2.4409	2.4404	2.4433	2.4421		2.4421	2.4413		2.4425	2.4413		2.4417	2.4409	
68	2.6772	2.6767	2.6795	2.6783		2.6783	2.6776		2.6787	2.6776		2.6779	2.6772	
72	2.8346	2.8341	2.8370	2.8358		2.8358	2.8350		2.8362	2.8350		2.8354	2.8346	
75	2.9528	2.9522	2.9551	2.9539	34 L / 14 L	2.9539	2.9531	19 L / 5 L	2.9543	2.9531	24 L / 5 L	2.9535	2.9528	15 L / 0 T
80	3.1496	3.1491	3.1520	3.1508		3.1507	3.1500		3.1512	3.1500		3.1504	3.1496	
85	3.3465	3.3459	3.3493	3.3479		3.3478	3.3469		3.3483	3.3469		3.3473	3.3465	
90	3.5433	3.5427	3.5461	3.5447		3.5446	3.5438		3.5452	3.5438		3.5442	3.5433	
95	3.7402	3.7396	3.7430	3.7416		3.7415	3.7406		3.7420	3.7406		3.7410	3.7402	
100	3.9370	3.9364	3.9398	3.9384		3.9383	3.9375		3.9389	3.9375		3.9379	3.9370	
110	4.3307	4.3301	4.3335	4.3321		4.3320	4.3312		4.3326	4.3312		4.3316	4.3307	
115	4.5276	4.5270	4.5304	4.5290	4.5289	4.5280	4.5294	4.5280	4.5284	4.5276				
120	4.7244	4.7238	4.7272	4.7258	4.7257	4.7249	4.7263	4.7249	4.7253	4.7244				
125	4.9213	4.9206	4.9245	4.9230	4.9228	4.9218	4.9234	4.9218	4.9222	4.9213				
130	5.1181	5.1174	5.1214	5.1198	40 L / 17 L	5.1196	5.1187	22 L / 6 L	5.1202	5.1187	28 L / 6 L	5.1191	5.1181	17 L / 0 T
140	5.5118	5.5111	5.5151	5.5135		5.5133	5.5124		5.5139	5.5124		5.5128	5.5118	
145	5.7087	5.7080	5.7119	5.7104		5.7102	5.7092		5.7108	5.7092		5.7096	5.7087	
150	5.9055	5.9048	5.9088	5.9072		5.9070	5.9061		5.9076	5.9061		5.9065	5.9055	
160	6.2992	6.2982	6.3025	6.3009		6.3007	6.2998		6.3013	6.2998		6.3002	6.2992	
165	6.4961	6.4951	6.4993	6.4978	43 L / 17 L	6.4976	6.4966	25 L / 6 L	6.4982	6.4966	31 L / 6 L	6.4970	6.4961	20 L / 0 T
170	6.6929	6.6919	6.6962	6.6946		6.6944	6.6935		6.6950	6.6935		6.6939	6.6929	
180	7.0866	7.0856	7.0899	7.0883		7.0881	7.0872		7.0887	7.0872		7.0876	7.0866	
190	7.4803	7.4791	7.4841	7.4823		7.4820	7.4809		7.4827	7.4809		7.4815	7.4803	
200	7.8740	7.8728	7.8778	7.8760	50 L / 20 L	7.8757	7.8746	29 L / 6 L	7.8764	7.8746	36 L / 6 L	7.8752	7.8740	23 L / 0 T
210	8.2677	8.2665	8.2715	8.2697		8.2694	8.2683		8.2701	8.2683		8.2689	8.2677	
215	8.4646	8.4634	8.4683	8.4665		8.4663	8.4652		8.4670	8.4652		8.4657	8.4646	
220	8.6614	8.6602	8.6652	8.6634		8.6631	8.6620		8.6638	8.6620		8.6626	8.6614	
225	8.8583	8.8571	8.8620	8.8602		8.8600	8.8589		8.8607	8.8589		8.8594	8.8583	
230	9.0551	9.0539	9.0589	9.0571		9.0569	9.0557		9.0575	9.0557		9.0563	9.0551	
240	9.4488	9.4476	9.4526	9.4508		9.4506	9.4494		9.4512	9.4494		9.4500	9.4488	
250	9.8425	9.8413	9.8463	9.8445	9.8443	9.8431	9.8449	9.8431	9.8437	9.8425				
260	10.2362	10.2348	10.2405	10.2384	56 L / 22 L	10.2381	10.2369	33 L / 7 L	10.2389	10.2369	41 L / 7 L	10.2375	10.2362	26 L / 0 T
270	10.6299	10.6285	10.6342	10.6321		10.6319	10.6306		10.6326	10.6306		10.6312	10.6299	

BEARING OUTSIDE DIAMETER				HOUSING BORE / RESULTING FIT (0.0001")										
mm	in		F7		RESULTING FIT	G6		RESULTING FIT	G7		RESULTING FIT	H6		RESULTING FIT
	O.D.	max	min	max		min	max		min	max		min	max	
280	11.0236	11.0222	11.0279	11.0258	56 L / 22 L	11.0256	11.0243	33 L / 7 L	11.0263	11.0243	41 L / 7 L	11.0249	11.0236	26 L / 0 T
290	11.4173	11.4159	11.4216	11.4195		11.4193	11.4180		11.4200	11.4180		11.4186	11.4173	
300	11.8110	11.8096	11.8153	11.8132		11.8130	11.8117		11.8137	11.8117		11.8123	11.8110	
310	12.2047	12.2033	12.2090	12.2069		12.2067	12.2054		12.2074	12.2054		12.2060	12.2047	
320	12.5984	12.5969	12.6031	12.6009	63 L / 24 L	12.6006	12.5991	37 L / 7 L	12.6014	12.5991	45 L / 7 L	12.5998	12.5984	30 L / 0 T
340	13.3858	13.3843	13.3905	13.3883		13.3880	13.3865		13.3888	13.3865		13.3872	13.3858	
360	14.1732	14.1717	14.1779	14.1757		14.1754	14.1739		14.1762	14.1739		14.1746	14.1732	
370	14.5669	14.5654	14.5716	14.5694		14.5691	14.5676		14.5699	14.5676		14.5683	14.5669	
380	14.9606	14.9591	14.9653	14.9631		14.9628	14.9613		14.9636	14.9613		14.9620	14.9606	
400	15.7480	15.7465	15.7527	15.7505		15.7502	15.7487		15.7510	15.7487		15.7494	15.7480	
420	16.5354	16.5337	16.5406	16.5381	69 L / 27 L	16.5378	16.5362	41 L / 8 L	16.5387	16.5362	50 L / 8 L	16.5370	16.5354	33 L / 0 T
440	17.3228	17.3211	17.3280	17.3255		17.3252	17.3236		17.3261	17.3236		17.3244	17.3228	
460	18.1102	18.1085	18.1154	18.1129		18.1126	18.1110		18.1135	18.1110		18.1118	18.1102	
480	18.8976	18.8959	18.9028	18.9003		18.9000	18.8984		18.9009	18.8984		18.8992	18.8976	
500	19.6850	19.6833	19.6902	19.6877	77 L / 30 L	19.6874	19.6858	46 L / 9 L	19.6883	19.6858	56 L / 9 L	19.6866	19.6850	37 L / 0 T
520	20.4724	20.4705	20.4782	20.4754		20.4750	20.4733		20.4761	20.4733		20.4742	20.4724	
540	21.2598	21.2579	21.2656	21.2628		21.2624	21.2607		21.2635	21.2607		21.2616	21.2598	
560	22.0472	22.0453	22.0530	22.0502		22.0498	22.0481		22.0509	22.0481		22.0490	22.0472	
580	22.8346	22.8327	22.8404	22.8376		22.8372	22.8355		22.8383	22.8355		22.8364	22.8346	
600	23.6220	23.6201	23.6278	23.6250		23.6246	23.6229		23.6257	23.6229		23.6238	23.6220	
620	24.4094	24.4075	24.4152	24.4124	24.4120	24.4103	24.4131	24.4103	24.4112	24.4094				
650	25.5906	25.5876	25.5969	25.5937	93 L / 31 L	25.5935	25.5915	59 L / 9 L	25.5946	25.5915	70 L / 9 L	25.5925	25.5906	49 L / 0 T
670	26.3780	26.3750	26.3843	26.3811		26.3809	26.3789		26.3820	26.3789		26.3799	26.3780	
680	26.7717	26.7687	26.7780	26.7748		26.7746	26.7726		26.7757	26.7726		26.7736	26.7717	
700	27.5591	27.5561	27.5654	27.5622		27.5620	27.5600		27.5631	27.5600		27.5610	27.5591	
720	28.3465	28.3435	28.3528	28.3496		28.3494	28.3474		28.3506	28.3474		28.3484	28.3465	
750	29.5276	29.5246	29.5339	29.5307		29.5305	29.5285		29.5317	29.5285		29.5295	29.5276	
760	29.9213	29.9183	29.9276	29.9244		29.9242	29.9222		29.9254	29.9222		29.9232	29.9213	
780	30.7087	30.7057	30.7150	30.7118		30.7116	30.7096		30.7128	30.7096		30.7106	30.7087	
790	31.1024	31.0994	31.1087	31.1055		31.1053	31.1033		31.1065	31.1033		31.1043	31.1024	
800	31.4961	31.4931	31.5024	31.4992		31.4990	31.4970		31.5002	31.4970		31.4980	31.4961	
820	32.2835	32.2795	32.2904	32.2869	32.2867	32.2845	32.2880	32.2845	32.2857	32.2835				
830	32.6772	32.6732	32.6841	32.6806	32.6804	32.6782	32.6817	32.6782	32.6794	32.6772				
850	33.4646	33.4606	33.4715	33.4680	33.4678	33.4656	33.4691	33.4656	33.4668	33.4646				
870	34.2520	34.2480	34.2589	34.2554	34.2552	34.2530	34.2565	34.2530	34.2542	34.2520				
920	36.2205	36.2165	36.2274	36.2239	36.2237	36.2215	36.2250	36.2215	36.2227	36.2205				
950	37.4016	37.3976	37.4085	37.4050	37.4048	37.4026	37.4061	37.4026	37.4038	37.4016				
980	38.5827	38.5787	38.5896	38.5861	38.5859	38.5837	38.5872	38.5837	38.5849	38.5827				
1000	39.3701	39.3661	39.3770	39.3735	39.3733	39.3711	39.3746	39.3711	39.3723	39.3701				
1150	45.2756	45.2707	45.2836	45.2794	129 L / 39 L	45.2793	45.2767	86 L / 11 L	45.2808	45.2767	102 L / 11 L	45.2782	45.2756	75 L / 0 T
1250	49.2126	49.2077	49.2206	49.2165		49.2163	49.2137		49.2178	49.2137		49.2152	49.2126	
1400	55.1181	55.1118	55.1274	55.1224	156 L / 43 L	55.1224	55.1193	106 L / 12 L	55.1242	55.1193	124 L / 12 L	55.1212	55.1181	94 L / 0 T
1600	62.9921	62.9858	63.0014	62.9965		62.9964	62.9933		62.9982	62.9933		62.9952	62.9921	
1800	70.8661	70.8583	70.8768	70.8709	185 L / 47 L	70.8710	70.8674	128 L / 13 L	70.8733	70.8674	150 L / 13 L	70.8698	70.8661	115 L / 0 T
2000	78.7402	78.7323	78.7508	78.7449		78.7450	78.7414		78.7473	78.7414		78.7438	78.7402	
2300	90.5512	90.5413	90.5632	90.5563	219 L / 51 L	90.5569	90.5525	155 L / 13 L	90.5594	90.5525	181 L / 13 L	90.5555	90.5512	142 L / 0 T
2500	98.4252	98.4154	98.4372	98.4303		98.4309	98.4265		98.4334	98.4265		98.4295	98.4252	

HOUSING BEARING-SEAT DIAMETERS

Table 13 - Housing Bore Diameters and Resulting Fits

Units: inch

BEARING OUTSIDE DIAMETER			HOUSING BORE / RESULTING FIT (0.0001")														
mm	in		H7		RESULTING FIT	H8		RESULTING FIT	H9		RESULTING FIT	H10		RESULTING FIT			
O.D.	max	min	max	min		max	min		max	min		max	min				
16	0.6299	0.6296	0.6306	0.6299	10 L / 0 T	0.6310	0.6299	14 L / 0 T	0.6316	0.6299	20 L / 0 T	0.6327	0.6299	31 L / 0 T			
19	0.7480	0.7477	0.7489	0.7480	12 L / 0 T	0.7493	0.7480	17 L / 0 T	0.7501	0.7480	24 L / 0 T	0.7513	0.7480	37 L / 0 T			
22	0.8661	0.8658	0.8670	0.8661		0.8674	0.8661		0.8682	0.8661		0.8694	0.8661		0.8694	0.8661	
24	0.9449	0.9445	0.9457	0.9449		0.9462	0.9449		0.9469	0.9449		0.9482	0.9449		1.0269	1.0236	
26	1.0236	1.0233	1.0244	1.0236		1.0249	1.0236		1.0257	1.0236		1.1057	1.1024		1.1844	1.1811	
28	1.1024	1.1020	1.1032	1.1024		1.1037	1.1024		1.1044	1.1024		1.2638	1.2598		1.3819	1.3780	
30	1.1811	1.1807	1.1819	1.1811	14 L / 0 T	1.1824	1.1811	20 L / 0 T	1.1831	1.1811	29 L / 0 T	1.1844	1.1811	44 L / 0 T			
32	1.2598	1.2594	1.2608	1.2598		1.2614	1.2598		1.2623	1.2598		1.4606	1.4567		1.5787	1.5748	
35	1.3780	1.3775	1.3789	1.3780		1.3795	1.3780		1.3804	1.3780		1.6575	1.6535		1.8543	1.8504	
37	1.4567	1.4563	1.4577	1.4567		1.4582	1.4567		1.4591	1.4567		2.0520	2.0472		2.1701	2.1654	
40	1.5748	1.5744	1.5758	1.5748		1.5763	1.5748		1.5772	1.5748		2.2447	2.2409		2.4457	2.4409	
42	1.6535	1.6531	1.6545	1.6535	17 L / 0 T	1.6551	1.6535	23 L / 0 T	1.6560	1.6535	34 L / 0 T	1.6575	1.6535	52 L / 0 T			
47	1.8504	1.8500	1.8514	1.8504		1.8519	1.8504		1.8528	1.8504		2.6819	2.6772		2.8394	2.8346	
52	2.0472	2.0467	2.0484	2.0472		2.0491	2.0472		2.0502	2.0472		2.9575	2.9528		3.1543	3.1496	
55	2.1654	2.1648	2.1665	2.1654		2.1672	2.1654		2.1683	2.1654		3.3499	3.3465		3.5488	3.5433	
62	2.4409	2.4404	2.4421	2.4409		2.4428	2.4409		2.4439	2.4409		3.7436	3.7402		3.9425	3.9370	
68	2.6772	2.6767	2.6783	2.6772	20 L / 0 T	2.6790	2.6772	27 L / 0 T	2.6801	2.6772	40 L / 0 T	2.6819	2.6772	61 L / 0 T			
72	2.8346	2.8341	2.8358	2.8346		2.8365	2.8346		2.8376	2.8346		4.3307	4.3307		4.5331	4.5276	
75	2.9528	2.9522	2.9539	2.9528		2.9546	2.9528		2.9557	2.9528		4.7244	4.7244		4.9276	4.9213	
80	3.1496	3.1491	3.1508	3.1496		3.1514	3.1496		3.1525	3.1496		5.1220	5.1181		5.3244	5.3181	
85	3.3465	3.3459	3.3478	3.3465		3.3486	3.3465		3.3499	3.3465		5.5157	5.5118		5.7150	5.7087	
90	3.5433	3.5427	3.5447	3.5433	23 L / 0 T	3.5454	3.5433	32 L / 0 T	3.5467	3.5433	46 L / 0 T	3.5488	3.5433	70 L / 0 T			
95	3.7402	3.7396	3.7415	3.7402		3.7423	3.7402		3.7436	3.7402		5.9094	5.9055		6.1088	6.1025	
100	3.9370	3.9364	3.9384	3.9370		3.9391	3.9370		3.9404	3.9370		6.3031	6.2992		6.5024	6.4961	
110	4.3307	4.3301	4.3321	4.3307		4.3328	4.3307		4.3341	4.3307		6.6969	6.6929		6.8962	6.8929	
115	4.5276	4.5270	4.5289	4.5276		4.5297	4.5276		4.5310	4.5276		7.0906	7.0866		7.2929	7.2866	
120	4.7244	4.7238	4.7258	4.7244	26 L / 0 T	4.7265	4.7244	35 L / 0 T	4.7278	4.7244	49 L / 0 T	4.7299	4.7244	73 L / 0 T			
125	4.9213	4.9206	4.9228	4.9213		4.9237	4.9213		4.9252	4.9213		7.4848	7.4803		7.6876	7.6803	
130	5.1181	5.1174	5.1197	5.1181		5.1206	5.1181		5.1220	5.1181		7.8785	7.8740		8.0750	8.0677	
140	5.5118	5.5111	5.5134	5.5118		5.5143	5.5118		5.5157	5.5118		8.2722	8.2677		8.4719	8.4646	
145	5.7087	5.7080	5.7102	5.7087		5.7111	5.7087		5.7126	5.7087		8.6691	8.6646		8.8687	8.8614	
150	5.9055	5.9048	5.9071	5.9055	30 L / 0 T	5.9080	5.9055	40 L / 0 T	5.9094	5.9055	57 L / 0 T	5.9118	5.9055	85 L / 0 T			
160	6.2992	6.2982	6.3008	6.2992		6.3017	6.2992		6.3031	6.2992		9.0596	9.0551		9.2624	9.2551	
165	6.4961	6.4951	6.4976	6.4961		6.4985	6.4961		6.5000	6.4961		9.4533	9.4488		9.6561	9.6488	
170	6.6929	6.6919	6.6945	6.6929		6.6954	6.6929		6.6969	6.6929		9.8470	9.8425		10.0498	10.0425	
180	7.0866	7.0856	7.0882	7.0866		7.0891	7.0866		7.0906	7.0866		10.2413	10.2362		10.4445	10.4362	
190	7.4803	7.4791	7.4821	7.4803	34 L / 0 T	7.4831	7.4803	46 L / 0 T	7.4848	7.4803	65 L / 0 T	7.4876	7.4803	96 L / 0 T			
200	7.8740	7.8728	7.8758	7.8740		7.8769	7.8740		7.8785	7.8740		10.6350	10.6299		10.8382	10.8299	
210	8.2677	8.2665	8.2695	8.2677		8.2706	8.2677		8.2722	8.2677							
215	8.4646	8.4634	8.4664	8.4646		8.4674	8.4646		8.4691	8.4646							
220	8.6614	8.6602	8.6632	8.6614		8.6643	8.6614		8.6659	8.6614							
225	8.8583	8.8571	8.8601	8.8583	34 L / 0 T	8.8611	8.8583	46 L / 0 T	8.8628	8.8583	65 L / 0 T	8.8656	8.8583	96 L / 0 T			
230	9.0551	9.0539	9.0569	9.0551		9.0580	9.0551		9.0596	9.0551							
240	9.4488	9.4476	9.4506	9.4488		9.4517	9.4488		9.4533	9.4488							
250	9.8425	9.8413	9.8443	9.8425		9.8454	9.8425		9.8470	9.8425							
260	10.2362	10.2348	10.2383	10.2362		10.2394	10.2362		10.2413	10.2362							
270	10.6299	10.6285	10.6320	10.6299	10.6331	10.6299	10.6350	10.6299									

BEARING OUTSIDE DIAMETER				HOUSING BORE / RESULTING FIT (0.0001")										
mm	in		H7		RESULTING FIT	H8		RESULTING FIT	H9		RESULTING FIT	H10		RESULTING FIT
	O.D.	max	min	max		min	max		min	max		min	max	
280	11.0236	11.0222	11.0257	11.0236	34 L / 0 T	11.0268	11.0236	46 L / 0 T	11.0287	11.0236	65 L / 0 T	11.0319	11.0236	96 L / 0 T
290	11.4173	11.4159	11.4194	11.4173		11.4205	11.4173		11.4224	11.4173		11.4256	11.4173	
300	11.8110	11.8096	11.8131	11.8110		11.8142	11.8110		11.8161	11.8110		11.8193	11.8110	
310	12.2047	12.2033	12.2068	12.2047		12.2079	12.2047		12.2098	12.2047		12.2130	12.2047	
320	12.5984	12.5969	12.6007	12.5984	38 L / 0 T	12.6019	12.5984	51 L / 0 T	12.6039	12.5984	71 L / 0 T	12.6075	12.5984	106 L / 0 T
340	13.3858	13.3843	13.3881	13.3858		13.3893	13.3858		13.3913	13.3858		13.3949	13.3858	
360	14.1732	14.1717	14.1755	14.1732		14.1767	14.1732		14.1787	14.1732		14.1823	14.1732	
370	14.5669	14.5654	14.5692	14.5669		14.5704	14.5669		14.5724	14.5669		14.5760	14.5669	
380	14.9606	14.9591	14.9629	14.9606		14.9641	14.9606		14.9661	14.9606		14.9697	14.9606	
400	15.7480	15.7465	15.7503	15.7480		15.7515	15.7480		15.7535	15.7480		15.7571	15.7480	
420	16.5354	16.5337	16.5379	16.5354	43 L / 0 T	16.5393	16.5354	56 L / 0 T	16.5415	16.5354	79 L / 0 T	16.5453	16.5354	116 L / 0 T
440	17.3228	17.3211	17.3253	17.3228		17.3267	17.3228		17.3289	17.3228		17.3327	17.3228	
460	18.1102	18.1085	18.1127	18.1102		18.1141	18.1102		18.1163	18.1102		18.1201	18.1102	
480	18.8976	18.8959	18.9001	18.8976		18.9015	18.8976		18.9037	18.8976		18.9075	18.8976	
500	19.6850	19.6833	19.6875	19.6850	47 L / 0 T	19.6889	19.6850	63 L / 0 T	19.6911	19.6850	89 L / 0 T	19.6949	19.6850	130 L / 0 T
520	20.4724	20.4705	20.4752	20.4724		20.4768	20.4724		20.4793	20.4724		20.4835	20.4724	
540	21.2598	21.2579	21.2626	21.2598		21.2642	21.2598		21.2667	21.2598		21.2709	21.2598	
560	22.0472	22.0453	22.0500	22.0472		22.0516	22.0472		22.0541	22.0472		22.0583	22.0472	
580	22.8346	22.8327	22.8374	22.8346		22.8390	22.8346		22.8415	22.8346		22.8457	22.8346	
600	23.6220	23.6201	23.6248	23.6220		23.6264	23.6220		23.6289	23.6220		23.6331	23.6220	
620	24.4094	24.4075	24.4122	24.4094		24.4138	24.4094		24.4163	24.4094		24.4205	24.4094	
650	25.5906	25.5876	25.5937	25.5906		61 L / 0 T	25.5955		25.5906	79 L / 0 T		25.5984	25.5906	
670	26.3780	26.3750	26.3811	26.3780	26.3829		26.3780	26.3858	26.3780		26.3906	26.3780		
680	26.7717	26.7687	26.7748	26.7717	26.7766		26.7717	26.7795	26.7717		26.7843	26.7717		
700	27.5591	27.5561	27.5622	27.5591	27.5640		27.5591	27.5669	27.5591		27.5717	27.5591		
720	28.3465	28.3435	28.3496	28.3465	28.3514		28.3465	28.3543	28.3465		28.3591	28.3465		
750	29.5276	29.5246	29.5307	29.5276	29.5325		29.5276	29.5354	29.5276		29.5402	29.5276		
760	29.9213	29.9183	29.9244	29.9213	29.9262		29.9213	29.9291	29.9213		29.9339	29.9213		
780	30.7087	30.7057	30.7118	30.7087	30.7136		30.7087	30.7165	30.7087		30.7213	30.7087		
790	31.1024	31.0994	31.1055	31.1024	31.1073		31.1024	31.1102	31.1024		31.1150	31.1024		
800	31.4961	31.4931	31.4992	31.4961	31.5010		31.4961	31.5039	31.4961		31.5087	31.4961		
820	32.2835	32.2795	32.2870	32.2835	75 L / 0 T	32.2890	32.2835	94 L / 0 T	32.2925	32.2835	130 L / 0 T	32.2976	32.2835	181 L / 0 T
830	32.6772	32.6732	32.6807	32.6772		32.6827	32.6772		32.6862	32.6772		32.6913	32.6772	
850	33.4646	33.4606	33.4681	33.4646		33.4701	33.4646		33.4736	33.4646		33.4787	33.4646	
870	34.2520	34.2480	34.2555	34.2520		34.2575	34.2520		34.2610	34.2520		34.2661	34.2520	
920	36.2205	36.2165	36.2240	36.2205		36.2260	36.2205		36.2295	36.2205		36.2346	36.2205	
950	37.4016	37.3976	37.4051	37.4016		37.4071	37.4016		37.4106	37.4016		37.4157	37.4016	
980	38.5827	38.5787	38.5862	38.5827		38.5882	38.5827		38.5917	38.5827		38.5969	38.5827	
1000	39.3701	39.3661	39.3736	39.3701		39.3756	39.3701		39.3791	39.3701		39.3843	39.3701	
1150	45.2756	45.2707	45.2797	45.2756	91 L / 0 T	45.2821	45.2756	114 L / 0 T	45.2858	45.2756	152 L / 0 T	45.2921	45.2756	215 L / 0 T
1250	49.2126	49.2077	49.2167	49.2126		49.2191	49.2126		49.2228	49.2126		49.2291	49.2126	
1400	55.1181	55.1118	55.1230	55.1181	112 L / 0 T	55.1258	55.1181	140 L / 0 T	55.1303	55.1181	185 L / 0 T	55.1378	55.1181	260 L / 0 T
1600	62.9921	62.9858	62.9970	62.9921		62.9998	62.9921		63.0043	62.9921		63.0118	62.9921	
1800	70.8661	70.8583	70.8720	70.8661	138 L / 0 T	70.8752	70.8661	169 L / 0 T	70.8807	70.8661	224 L / 0 T	70.8898	70.8661	315 L / 0 T
2000	78.7402	78.7323	78.7461	78.7402		78.7492	78.7402		78.7547	78.7402		78.7638	78.7402	
2300	90.5512	90.5413	90.5581	90.5512	167 L / 0 T	90.5622	90.5512	209 L / 0 T	90.5685	90.5512	272 L / 0 T	90.5787	90.5512	374 L / 0 T
2500	98.4252	98.4154	98.4321	98.4252		98.4362	98.4252		98.4425	98.4252		98.4528	98.4252	

HOUSING BEARING-SEAT DIAMETERS

Table 13 - Housing Bore Diameters and Resulting Fits

Units: inch

BEARING OUTSIDE DIAMETER			HOUSING BORE / RESULTING FIT (0.0001")											
mm	in		J6		RESULTING FIT	J7		RESULTING FIT	J55		RESULTING FIT	J56		RESULTING FIT
	O.D.	max	min	max		min	max		min	max		min	max	
16	0.6299	0.6296	0.6302	0.6297	6 L / 2 T	0.6303	0.6296	7 L / 3 T	0.6301	0.6298	5 L / 2 T	0.6301	0.6297	5 L / 2 T
19	0.7480	0.7477	0.7483	0.7478	7 L / 2 T	0.7485	0.7477	8 L / 4 T	0.7482	0.7479	5 L / 2 T	0.7483	0.7478	6 L / 3 T
22	0.8661	0.8658	0.8665	0.8659		0.8666	0.8658		0.8663	0.8660		0.8664	0.8659	
24	0.9449	0.9445	0.9452	0.9447		0.9454	0.9445		0.9451	0.9447		0.9451	0.9446	
26	1.0236	1.0233	1.0239	1.0234		1.0241	1.0233		1.0238	1.0234		1.0239	1.0234	
28	1.1024	1.1020	1.1027	1.1022		1.1028	1.1020		1.1025	1.1022		1.1026	1.1021	
30	1.1811	1.1807	1.1814	1.1809	1.1816	1.1807	1.1813	1.1809	1.1814	1.1808				
32	1.2598	1.2594	1.2602	1.2596	8 L / 2 T	1.2604	1.2594	10 L / 4 T	1.2601	1.2596	6 L / 2 T	1.2602	1.2595	7 L / 3 T
35	1.3780	1.3775	1.3783	1.3777		1.3785	1.3775		1.3782	1.3777		1.3783	1.3776	
37	1.4567	1.4563	1.4571	1.4565		1.4572	1.4563		1.4569	1.4565		1.4570	1.4564	
40	1.5748	1.5744	1.5752	1.5746		1.5754	1.5744		1.5750	1.5746		1.5751	1.5745	
42	1.6535	1.6531	1.6539	1.6533		1.6541	1.6531		1.6538	1.6533		1.6539	1.6532	
47	1.8504	1.8500	1.8508	1.8502	1.8509	1.8500	1.8506	1.8502	1.8507	1.8501				
52	2.0472	2.0467	2.0478	2.0470	10 L / 2 T	2.0480	2.0468	12 L / 5 T	2.0475	2.0470	8 L / 3 T	2.0476	2.0469	9 L / 4 T
55	2.1654	2.1648	2.1659	2.1651		2.1661	2.1649		2.1656	2.1651		2.1657	2.1650	
62	2.4409	2.4404	2.4415	2.4407		2.4417	2.4405		2.4412	2.4407		2.4413	2.4406	
68	2.6772	2.6767	2.6777	2.6769		2.6779	2.6767		2.6774	2.6769		2.6775	2.6768	
72	2.8346	2.8341	2.8352	2.8344		2.8354	2.8342		2.8349	2.8344		2.8350	2.8343	
75	2.9528	2.9522	2.9533	2.9525	2.9535	2.9523	2.9530	2.9525	2.9531	2.9524				
80	3.1496	3.1491	3.1501	3.1494	3.1503	3.1491	3.1499	3.1494	3.1500	3.1492				
85	3.3465	3.3459	3.3471	3.3462	12 L / 2 T	3.3473	3.3459	15 L / 5 T	3.3468	3.3462	9 L / 3 T	3.3469	3.3460	10 L / 4 T
90	3.5433	3.5427	3.5439	3.5431		3.5442	3.5428		3.5436	3.5430		3.5437	3.5429	
95	3.7402	3.7396	3.7408	3.7399		3.7410	3.7396		3.7405	3.7399		3.7406	3.7397	
100	3.9370	3.9364	3.9376	3.9368		3.9379	3.9365		3.9373	3.9367		3.9374	3.9366	
110	4.3307	4.3301	4.3313	4.3305		4.3316	4.3302		4.3310	4.3304		4.3311	4.3303	
115	4.5276	4.5270	4.5282	4.5273	4.5284	4.5270	4.5279	4.5273	4.5280	4.5271				
120	4.7244	4.7238	4.7250	4.7242	4.7253	4.7239	4.7247	4.7241	4.7248	4.7240				
125	4.9213	4.9206	4.9220	4.9210	14 L / 3 T	4.9223	4.9207	17 L / 6 T	4.9216	4.9209	11 L / 4 T	4.9218	4.9208	12 L / 5 T
130	5.1181	5.1174	5.1188	5.1178		5.1191	5.1176		5.1185	5.1178		5.1186	5.1176	
140	5.5118	5.5111	5.5125	5.5115		5.5128	5.5113		5.5122	5.5115		5.5123	5.5113	
145	5.7087	5.7080	5.7094	5.7084		5.7097	5.7081		5.7090	5.7083		5.7092	5.7082	
150	5.9055	5.9048	5.9062	5.9052		5.9065	5.9050		5.9059	5.9052		5.9060	5.9050	
160	6.2992	6.2982	6.2999	6.2989	17 L / 3 T	6.3002	6.2987	20 L / 6 T	6.2996	6.2989	13 L / 4 T	6.2997	6.2987	15 L / 5 T
165	6.4961	6.4951	6.4968	6.4958		6.4971	6.4955		6.4964	6.4957		6.4966	6.4956	
170	6.6929	6.6919	6.6936	6.6926		6.6939	6.6924		6.6933	6.6926		6.6934	6.6924	
180	7.0866	7.0856	7.0873	7.0863		7.0876	7.0861		7.0870	7.0863		7.0871	7.0861	
190	7.4803	7.4791	7.4812	7.4800		7.4815	7.4797		7.4807	7.4799		7.4809	7.4797	
200	7.8740	7.8728	7.8749	7.8737	20 L / 3 T	7.8752	7.8734	24 L / 6 T	7.8744	7.8736	16 L / 4 T	7.8746	7.8734	18 L / 6 T
210	8.2677	8.2665	8.2686	8.2674		8.2689	8.2671		8.2681	8.2673		8.2683	8.2671	
215	8.4646	8.4634	8.4654	8.4643		8.4657	8.4639		8.4650	8.4642		8.4651	8.4640	
220	8.6614	8.6602	8.6623	8.6611		8.6626	8.6608		8.6618	8.6610		8.6620	8.6608	
225	8.8583	8.8571	8.8591	8.8580		8.8594	8.8576		8.8587	8.8579		8.8588	8.8577	
230	9.0551	9.0539	9.0560	9.0548	24 L / 3 T	9.0563	9.0545	28 L / 6 T	9.0555	9.0547	18 L / 5 T	9.0557	9.0545	20 L / 6 T
240	9.4488	9.4476	9.4497	9.4485		9.4500	9.4482		9.4492	9.4484		9.4494	9.4482	
250	9.8425	9.8413	9.8434	9.8422		9.8437	9.8419		9.8429	9.8421		9.8431	9.8419	
260	10.2362	10.2348	10.2372	10.2359		10.2376	10.2356		10.2367	10.2358		10.2369	10.2356	
270	10.6299	10.6285	10.6309	10.6296		10.6313	10.6293		10.6304	10.6295		10.6306	10.6293	

BEARING OUTSIDE DIAMETER				HOUSING BORE / RESULTING FIT (0.0001")														
mm	in		J6		RESULTING FIT	J7		RESULTING FIT	J5		RESULTING FIT	J6		RESULTING FIT				
	O.D.	max	min	max		min	max		min	max		min	max		min			
280	11.0236	11.0222	11.0246	11.0233	24 L / 3 T	11.0250	11.0230	28 L / 6 T	11.0241	11.0232	18 L / 5 T	11.0243	11.0230	20 L / 6 T				
290	11.4173	11.4159	11.4183	11.4170		11.4187	11.4167		11.4178	11.4169		11.4180	11.4167					
300	11.8110	11.8096	11.8120	11.8107		11.8124	11.8104		11.8115	11.8106		11.8117	11.8104					
310	12.2047	12.2033	12.2057	12.2044		12.2061	12.2041		12.2052	12.2043		12.2054	12.2041					
320	12.5984	12.5969	12.5996	12.5981	27 L / 3 T	12.6000	12.5977	31 L / 7 T	12.5989	12.5979	21 L / 5 T	12.5991	12.5977	23 L / 7 T				
340	13.3858	13.3843	13.3870	13.3856		13.3874	13.3851		13.3863	13.3853		13.3865	13.3851					
360	14.1732	14.1717	14.1744	14.1730		14.1748	14.1725		14.1737	14.1727		14.1739	14.1725					
370	14.5669	14.5654	14.5681	14.5667		14.5685	14.5662		14.5674	14.5664		14.5676	14.5662					
380	14.9606	14.9591	14.9618	14.9604		14.9622	14.9599		14.9611	14.9601		14.9613	14.9599					
400	15.7480	15.7465	15.7492	15.7478	31 L / 3 T	15.7496	15.7473	35 L / 8 T	15.7485	15.7475	23 L / 5 T	15.7487	15.7473	26 L / 8 T				
420	16.5354	16.5337	16.5367	16.5352		16.5371	16.5346		16.5360	16.5349		16.5362	16.5346					
440	17.3228	17.3211	17.3241	17.3226		17.3245	17.3220		17.3234	17.3223		17.3236	17.3220					
460	18.1102	18.1085	18.1115	18.1100		18.1119	18.1094		18.1108	18.1097		18.1110	18.1094					
480	18.8976	18.8959	18.8989	18.8974	31 L / 3 T	18.8993	18.8969	35 L / 8 T	18.8982	18.8971	23 L / 5 T	18.8984	18.8969	26 L / 8 T				
500	19.6850	19.6833	19.6863	19.6848		19.6867	19.6843		19.6856	19.6845		19.6858	19.6843					
520	20.4724	20.4705	--	--		--	--		20.4730	20.4719		20.4733	20.4716					
540	21.2598	21.2579	--	--		--	--		21.2604	21.2593		21.2607	21.2590					
560	22.0472	22.0453	--	--	31 L / 3 T	--	--	35 L / 8 T	22.0478	22.0467	25 L / 6 T	22.0481	22.0464	28 L / 9 T				
580	22.8346	22.8327	--	--		--	--		22.8352	22.8341		22.8355	22.8338					
600	23.6220	23.6201	--	--		--	--		23.6226	23.6215		23.6229	23.6212					
620	24.4094	24.4075	--	--		--	--		24.4100	24.4089		24.4103	24.4086					
650	25.5906	25.5876	--	--		--	--		25.5912	25.5899		25.5915	25.5896					
670	26.3780	26.3750	--	--		--	--		26.3786	26.3773		26.3789	26.3770					
680	26.7717	26.7687	--	--		--	--		26.7723	26.7710		26.7726	26.7707					
700	27.5591	27.5561	--	--		--	--		27.5597	27.5584		27.5600	27.5581					
720	28.3465	28.3435	--	--		--	--		28.3471	28.3458		28.3474	28.3455					
750	29.5276	29.5246	--	--		31 L / 3 T	--		--	35 L / 8 T		29.5282	29.5269		36 L / 6 T	29.5285	29.5266	39 L / 10 T
760	29.9213	29.9183	--	--	--		--	29.9219	29.9206		29.9222	29.9203						
780	30.7087	30.7057	--	--	--		--	30.7093	30.7080		30.7096	30.7077						
790	31.1024	31.0994	--	--	--		--	31.1030	31.1017		31.1033	31.1014						
800	31.4961	31.4931	--	--	--		--	31.4967	31.4954		31.4970	31.4951						
820	32.2835	32.2795	--	--	--		--	32.2842	32.2828		32.2846	32.2824						
830	32.6772	32.6732	--	--	--		--	32.6779	32.6765		32.6783	32.6761						
850	33.4646	33.4606	--	--	--		--	33.4653	33.4639		33.4657	33.4635						
870	34.2520	34.2480	--	--	--		--	34.2527	34.2513		34.2531	34.2509						
920	36.2205	36.2165	--	--	31 L / 3 T		--	--	35 L / 8 T		36.2212	36.2198	46 L / 7 T	36.2216		36.2194	50 L / 11 T	
950	37.4016	37.3976	--	--		--	--	37.4023		37.4009	37.4027	37.4005						
980	38.5827	38.5787	--	--		--	--	38.5834		38.5820	38.5838	38.5816						
1000	39.3701	39.3661	--	--		--	--	39.3708		39.3694	39.3712	39.3690						
1150	45.2756	45.2707	--	--		--	--	45.2764		45.2748	45.2769	45.2743						
1250	49.2126	49.2077	--	--		--	--	49.2134		49.2118	49.2139	49.2113						
1400	55.1181	55.1118	--	--		31 L / 3 T	--	--		35 L / 8 T	55.1191	55.1171		73 L / 10 T	55.1196	55.1166		78 L / 15 T
1600	62.9921	62.9858	--	--			--	--			62.9931	62.9911			62.9937	62.9906		
1800	70.8661	70.8583	--	--			--	--			70.8673	70.8650			70.8680	70.8643		
2000	78.7402	78.7323	--	--			--	--			78.7413	78.7390			78.7420	78.7383		
2300	90.5512	90.5413	--	--	31 L / 3 T	--	--	35 L / 8 T	90.5526	90.5498	91 L / 12 T	90.5533	90.5490	97 L / 18 T				
2500	98.4252	98.4154	--	--		--	--		98.4266	98.4238		98.4274	98.4230					
											112 L / 14 T			120 L / 22 T				

HOUSING BEARING-SEAT DIAMETERS

Table 13 - Housing Bore Diameters and Resulting Fits

Units: inch

BEARING OUTSIDE DIAMETER			HOUSING BORE / RESULTING FIT (0.0001")															
mm	in		J57		RESULTING FIT	K5		RESULTING FIT	K6		RESULTING FIT	K7		RESULTING FIT				
	O.D.	max	min	max		min	max		min	max		min	max		min			
16	0.6299	0.6296	0.6303	0.6296	7 L / 4 T	0.6300	0.6297	4 L / 2 T	0.6300	0.6296	4 L / 4 T	0.6302	0.6294	6 L / 5 T				
19	0.7480	0.7477	0.7484	0.7476	8 L / 4 T	0.7481	0.7477	4 L / 3 T	0.7481	0.7476	4 L / 4 T	0.7483	0.7474	6 L / 6 T				
22	0.8661	0.8658	0.8666	0.8657		0.8662	0.8658		0.8662	0.8657		0.8664	0.8656					
24	0.9449	0.9445	0.9453	0.9445		0.9449	0.9446		0.9450	0.9444		0.9451	0.9443					
26	1.0236	1.0233	1.0240	1.0232		1.0237	1.0233		1.0237	1.0232		1.0239	1.0230					
28	1.1024	1.1020	1.1028	1.1019		1.1024	1.1020		1.1024	1.1019		1.1026	1.1018					
30	1.1811	1.1807	1.1815	1.1807		1.1811	1.1808		1.1812	1.1807		1.1813	1.1805					
32	1.2598	1.2594	1.2603	1.2594	9 L / 5 T	1.2599	1.2595	5 L / 4 T	1.2600	1.2593	6 L / 5 T	1.2601	1.2591	7 L / 7 T				
35	1.3780	1.3775	1.3784	1.3775		1.3780	1.3776		1.3781	1.3774		1.3782	1.3772					
37	1.4567	1.4563	1.4572	1.4562		1.4568	1.4563		1.4568	1.4562		1.4570	1.4560					
40	1.5748	1.5744	1.5753	1.5743		1.5749	1.5744		1.5749	1.5743		1.5751	1.5741					
42	1.6535	1.6531	1.6540	1.6531		1.6536	1.6532		1.6537	1.6530		1.6538	1.6528					
47	1.8504	1.8500	1.8509	1.8499		1.8505	1.8500		1.8505	1.8499		1.8507	1.8497					
52	2.0472	2.0467	2.0478	2.0467	11 L / 6 T	2.0474	2.0469	6 L / 4 T	2.0474	2.0467	7 L / 6 T	2.0476	2.0464	9 L / 8 T				
55	2.1654	2.1648	2.1659	2.1648		2.1655	2.1650		2.1655	2.1648		2.1657	2.1645					
62	2.4409	2.4404	2.4415	2.4404		2.4411	2.4406		2.4411	2.4404		2.4413	2.4401					
68	2.6772	2.6767	2.6778	2.6766		2.6773	2.6768		2.6773	2.6766		2.6775	2.6763					
72	2.8346	2.8341	2.8352	2.8341		2.8348	2.8343		2.8348	2.8341		2.8350	2.8338					
75	2.9528	2.9522	2.9533	2.9522		2.9529	2.9524		2.9529	2.9522		2.9531	2.9519					
80	3.1496	3.1491	3.1502	3.1490	13 L / 7 T	3.1497	3.1492	7 L / 5 T	3.1498	3.1490	7 L / 7 T	3.1500	3.1488	10 L / 10 T				
85	3.3465	3.3459	3.3471	3.3458		3.3465	3.3459		3.3466	3.3457		3.3469	3.3455					
90	3.5433	3.5427	3.5440	3.5426		3.5434	3.5428		3.5435	3.5426		3.5437	3.5423					
95	3.7402	3.7396	3.7408	3.7395		3.7402	3.7396		3.7403	3.7394		3.7406	3.7392					
100	3.9370	3.9364	3.9377	3.9363		3.9371	3.9365		3.9372	3.9363		3.9374	3.9360					
110	4.3307	4.3301	4.3314	4.3300		4.3308	4.3302		4.3309	4.3300		4.3311	4.3297					
115	4.5276	4.5270	4.5282	4.5269	4.5276	4.5270	4.5277	4.5269	4.5280	4.5266								
120	4.7244	4.7238	4.7251	4.7237	4.7245	4.7239	4.7246	4.7237	4.7248	4.7234								
125	4.9213	4.9206	4.9220	4.9205	4.9214	4.9207	4.9214	4.9204	4.9217	4.9202								
130	5.1181	5.1174	5.1189	5.1173	15 L / 8 T	5.1182	5.1175	8 L / 6 T	5.1183	5.1173	9 L / 8 T	5.1186	5.1170	12 L / 5 T				
140	5.5118	5.5111	5.5126	5.5110		5.5119	5.5112		5.5120	5.5110		5.5123	5.5107					
145	5.7087	5.7080	5.7094	5.7079		5.7088	5.7081		5.7088	5.7078		5.7091	5.7076					
150	5.9055	5.9048	5.9063	5.9047		5.9056	5.9049		5.9057	5.9047		5.9060	5.9044					
160	6.2992	6.2982	6.3000	6.2984		6.2993	6.2986		6.2994	6.2984		6.2997	6.2981					
165	6.4961	6.4951	6.4969	6.4953		6.4962	6.4955		6.4962	6.4952		6.4965	6.4950					
170	6.6929	6.6919	6.6937	6.6921	6.6930	6.6923	6.6931	6.6921	6.6934	6.6918								
180	7.0866	7.0856	7.0874	7.0858	18 L / 8 T	7.0867	7.0860	11 L / 6 T	7.0868	7.0858	11 L / 8 T	7.0871	7.0855	15 L / 11 T				
190	7.4803	7.4791	7.4812	7.4794		7.4804	7.4796		7.4805	7.4794		7.4808	7.4790					
200	7.8740	7.8728	7.8749	7.8731		7.8741	7.8733		7.8742	7.8731		7.8745	7.8727					
210	8.2677	8.2665	8.2686	8.2668		8.2678	8.2670		8.2679	8.2668		8.2682	8.2664					
215	8.4646	8.4634	8.4655	8.4637		8.4646	8.4639		8.4648	8.4636		8.4651	8.4633					
220	8.6614	8.6602	8.6623	8.6605		8.6615	8.6607		8.6616	8.6605		8.6619	8.6601					
225	8.8583	8.8571	8.8592	8.8574	21 L / 9 T	8.8583	8.8576	13 L / 7 T	8.8585	8.8573	14 L / 9 T	8.8588	8.8570	17 L / 13 T				
230	9.0551	9.0539	9.0560	9.0542		9.0552	9.0544		9.0553	9.0542		9.0556	9.0538					
240	9.4488	9.4476	9.4497	9.4479		9.4489	9.4481		9.4490	9.4479		9.4493	9.4475					
250	9.8425	9.8413	9.8434	9.8416		9.8426	9.8418		9.8427	9.8416		9.8430	9.8412					
260	10.2362	10.2348	10.2372	10.2352		24 L / 10 T	10.2363		10.2354	15 L / 8 T		10.2364	10.2352		16 L / 11 T	10.2369	10.2348	20 L / 14 T
270	10.6299	10.6285	10.6309	10.6289			10.6300		10.6291			10.6301	10.6289			10.6306	10.6285	

BEARING OUTSIDE DIAMETER					HOUSING BORE / RESULTING FIT (0.0001")										
mm	in		J57		RESULTING FIT	K5		RESULTING FIT	K6		RESULTING FIT	K7		RESULTING FIT	
	O.D.	max	min	max		min	max		min	max		min	max		min
280	11.0236	11.0222	11.0246	11.0226	24 L / 10 T	11.0237	11.0228	15 L / 8 T	11.0238	11.0226	16 L / 11 T	11.0243	11.0222	20 L / 14 T	
290	11.4173	11.4159	11.4183	11.4163		11.4174	11.4165		11.4175	11.4163		11.4180	11.4159		
300	11.8110	11.8096	11.8120	11.8100		11.8111	11.8102		11.8112	11.8100		11.8117	11.8096		
310	12.2047	12.2033	12.2057	12.2037		12.2048	12.2039		12.2049	12.2037		12.2054	12.2033		
320	12.5984	12.5969	12.5995	12.5973	27 L / 11 T	12.5985	12.5976	17 L / 9 T	12.5987	12.5973	19 L / 11 T	12.5991	12.5969	22 L / 16 T	
340	13.3858	13.3843	13.3869	13.3847		13.3859	13.3850		13.3861	13.3847		13.3865	13.3843		
360	14.1732	14.1717	14.1744	14.1721		14.1733	14.1724		14.1735	14.1721		14.1739	14.1717		
370	14.5669	14.5654	14.5681	14.5658		14.5670	14.5661		14.5672	14.5658		14.5676	14.5654		
380	14.9606	14.9591	14.9618	14.9595		14.9607	14.9598		14.9609	14.9595		14.9613	14.9591		
400	15.7480	15.7465	15.7492	15.7469		15.7481	15.7472		15.7483	15.7469		15.7487	15.7465		
420	16.5354	16.5337	16.5367	16.5342	30 L / 12 T	16.5355	16.5344	19 L / 10 T	16.5357	16.5342	21 L / 13 T	16.5361	16.5337	25 L / 18 T	
440	17.3228	17.3211	17.3241	17.3216		17.3229	17.3219		17.3231	17.3216		17.3235	17.3211		
460	18.1102	18.1085	18.1115	18.1090		18.1103	18.1093		18.1106	18.1090		18.1109	18.1085		
480	18.8976	18.8959	18.8989	18.8964		18.8977	18.8967		18.8980	18.8964		18.8983	18.8959		
500	19.6850	19.6833	19.6863	19.6838	33 L / 14 T	19.6851	19.6841	19.6854	19.6838	19.6857	19.6833	20 L / 17 T	19.6857	19.6833	20 L / 28 T
520	20.4724	20.4705	20.4738	20.4711		--	--	20.4724	20.4707	20.4724	20.4697				
540	21.2598	21.2579	21.2612	21.2585		--	--	21.2598	21.2581	21.2598	21.2571				
560	22.0472	22.0453	22.0486	22.0459		--	--	22.0472	22.0455	22.0472	22.0445				
580	22.8346	22.8327	22.8360	22.8333		--	--	22.8346	22.8329	22.8346	22.8319				
600	23.6220	23.6201	23.6234	23.6207		--	--	23.6220	23.6203	23.6220	23.6193				
620	24.4094	24.4075	24.4108	24.4081		--	--	24.4094	24.4077	24.4094	24.4067				
650	25.5906	25.5876	25.5921	25.5890		--	--	25.5906	25.5886	25.5906	25.5874				
670	26.3780	26.3750	26.3795	26.3764		--	--	26.3780	26.3760	26.3780	26.3748				
680	26.7717	26.7687	26.7732	26.7701		--	--	26.7717	26.7697	26.7717	26.7685				
700	27.5591	27.5561	27.5606	27.5575	45 L / 16 T	--	--	27.5591	27.5571	27.5591	27.5559	30 L / 20 T	27.5591	27.5559	30 L / 31 T
720	28.3465	28.3435	28.3480	28.3449		--	--	28.3465	28.3445	28.3465	28.3433				
750	29.5276	29.5246	29.5291	29.5260		--	--	29.5276	29.5256	29.5276	29.5244				
760	29.9213	29.9183	29.9228	29.9197		--	--	29.9213	29.9193	29.9213	29.9181				
780	30.7087	30.7057	30.7102	30.7071		--	--	30.7087	30.7067	30.7087	30.7055				
790	31.1024	31.0994	31.1039	31.1008		--	--	31.1024	31.1004	31.1024	31.0992				
800	31.4961	31.4931	31.4976	31.4945		--	--	31.4961	31.4941	31.4961	31.4929				
820	32.2835	32.2795	32.2852	32.2817		--	--	32.2835	32.2813	32.2835	32.2799				
830	32.6772	32.6732	32.6789	32.6754		--	--	32.6772	32.6750	32.6772	32.6736				
850	33.4646	33.4606	33.4663	33.4628		57 L / 18 T	--	--	33.4646	33.4624	33.4646		33.4610	39 L / 22 T	
870	34.2520	34.2480	34.2537	34.2502	--		--	34.2520	34.2498	34.2520	34.2484				
920	36.2205	36.2165	36.2222	36.2187	--		--	36.2205	36.2183	36.2205	36.2169				
950	37.4016	37.3976	37.4033	37.3998	--		--	37.4016	37.3994	37.4016	37.3980				
980	38.5827	38.5787	38.5844	38.5809	--		--	38.5827	38.5805	38.5827	38.5791				
1000	39.3701	39.3661	39.3719	39.3683	--		--	39.3701	39.3679	39.3701	39.3665				
1150	45.2756	45.2707	45.2777	45.2735	70 L / 21 T	--	--	45.2756	45.2730	45.2756	45.2715	49 L / 26 T	45.2756	45.2715	49 L / 41 T
1250	49.2126	49.2077	49.2147	49.2105		--	--	49.2126	49.2100	49.2126	49.2085				
1400	55.1181	55.1118	55.1206	55.1156	88 L / 25 T	--	--	55.1181	55.1150	55.1181	55.1132	63 L / 31 T	55.1181	55.1132	63 L / 49 T
1600	62.9921	62.9858	62.9946	62.9897		--	--	62.9921	62.9891	62.9921	62.9872				
1800	70.8661	70.8583	70.8691	70.8632	108 L / 30 T	--	--	70.8661	70.8625	70.8661	70.8602	79 L / 36 T	70.8661	70.8602	79 L / 59 T
2000	78.7402	78.7323	78.7431	78.7372		--	--	78.7402	78.7365	78.7402	78.7343				
2300	90.5512	90.5413	90.5546	90.5477	133 L / 34 T	--	--	90.5512	90.5469	90.5512	90.5443	98 L / 43 T	90.5512	90.5443	98 L / 69 T
2500	98.4252	98.4154	98.4286	98.4218		--	--	98.4252	98.4209	98.4252	98.4183				

HOUSING BEARING-SEAT DIAMETERS

Table 13 - Housing Bore Diameters and Resulting Fits

Units: inch

BEARING OUTSIDE DIAMETER			HOUSING BORE / RESULTING FIT (0.0001")											
mm	in		M5		RESULTING FIT	M6		RESULTING FIT	M7		RESULTING FIT	N5		RESULTING FIT
O.D.	max	min	max	min		max	min		max	min		max	min	
16	0.6299	0.6296	0.6298	0.6294	2 L / 5 T	0.6298	0.6293	2 L / 6 T	0.6299	0.6292	3 L / 7 T	0.6296	0.6293	0 T / 7 T
19	0.7480	0.7477	0.7478	0.7475	2 L / 6 T	0.7479	0.7474	2 L / 7 T	0.7480	0.7472	4 L / 8 T	0.7476	0.7472	1 T / 8 T
22	0.8661	0.8658	0.8659	0.8656		0.8660	0.8655		0.8661	0.8653		0.8657	0.8653	
24	0.9449	0.9445	0.9447	0.9443		0.9447	0.9442		0.9449	0.9441		0.9444	0.9441	
26	1.0236	1.0233	1.0234	1.0231		1.0235	1.0230		1.0236	1.0228		1.0231	1.0228	
28	1.1024	1.1020	1.1022	1.1018		1.1022	1.1017		1.1024	1.1015		1.1019	1.1015	
30	1.1811	1.1807	1.1809	1.1806	1.1809	1.1804	1.1811	1.1803	1.1806	1.1803				
32	1.2598	1.2594	1.2596	1.2592	2 L / 6 T	1.2597	1.2591	3 L / 8 T	1.2598	1.2589	4 L / 10 T	1.2593	1.2589	1 T / 9 T
35	1.3780	1.3775	1.3778	1.3773		1.3778	1.3772		1.3780	1.3770		1.3774	1.3770	
37	1.4567	1.4563	1.4565	1.4561		1.4565	1.4559		1.4567	1.4557		1.4562	1.4557	
40	1.5748	1.5744	1.5746	1.5742		1.5746	1.5740		1.5748	1.5738		1.5743	1.5739	
42	1.6535	1.6531	1.6533	1.6529		1.6534	1.6528		1.6535	1.6526		1.6530	1.6526	
47	1.8504	1.8500	1.8502	1.8498	1.8502	1.8496	1.8504	1.8494	1.8499	1.8494				
52	2.0472	2.0467	2.0470	2.0465	3 L / 7 T	2.0470	2.0463	3 L / 9 T	2.0472	2.0461	5 L / 12 T	2.0467	2.0461	1 T / 11 T
55	2.1654	2.1648	2.1651	2.1646		2.1652	2.1644		2.1654	2.1642		2.1648	2.1643	
62	2.4409	2.4404	2.4407	2.4402		2.4407	2.4400		2.4409	2.4398		2.4404	2.4398	
68	2.6772	2.6767	2.6769	2.6764		2.6770	2.6762		2.6772	2.6760		2.6766	2.6761	
72	2.8346	2.8341	2.8344	2.8339		2.8344	2.8337		2.8346	2.8335		2.8341	2.8335	
75	2.9528	2.9522	2.9525	2.9520	2.9526	2.9518	2.9528	2.9516	2.9522	2.9517				
80	3.1496	3.1491	3.1494	3.1489	3.1494	3.1487	3.1496	3.1484	3.1490	3.1485				
85	3.3465	3.3459	3.3461	3.3456	3 L / 9 T	3.3462	3.3454	4 L / 11 T	3.3465	3.3451	6 L / 14 T	3.3457	3.3452	1 T / 13 T
90	3.5433	3.5427	3.5430	3.5424		3.5431	3.5422		3.5433	3.5419		3.5426	3.5420	
95	3.7402	3.7396	3.7398	3.7393		3.7399	3.7391		3.7402	3.7388		3.7394	3.7389	
100	3.9370	3.9364	3.9367	3.9361		3.9368	3.9359		3.9370	3.9356		3.9363	3.9357	
110	4.3307	4.3301	4.3304	4.3298		4.3305	4.3296		4.3307	4.3293		4.3300	4.3294	
115	4.5276	4.5270	4.5272	4.5267	4.5273	4.5265	4.5276	4.5262	4.5269	4.5263				
120	4.7244	4.7238	4.7241	4.7235	4.7242	4.7233	4.7244	4.7230	4.7237	4.7231				
125	4.9213	4.9206	4.9209	4.9202	4.9209	4.9200	4.9213	4.9197	4.9204	4.9197				
130	5.1181	5.1174	5.1178	5.1170	4 L / 11 T	5.1178	5.1168	4 L / 13 T	5.1181	5.1165	7 L / 16 T	5.1173	5.1166	1 T / 15 T
140	5.5118	5.5111	5.5115	5.5107		5.5115	5.5105		5.5118	5.5102		5.5110	5.5103	
145	5.7087	5.7080	5.7083	5.7076		5.7083	5.7074		5.7087	5.7071		5.7078	5.7071	
150	5.9055	5.9048	5.9052	5.9044		5.9052	5.9042		5.9055	5.9039		5.9047	5.9040	
160	6.2992	6.2982	6.2989	6.2981		6.2989	6.2979		6.2992	6.2976		6.2984	6.2977	
165	6.4961	6.4951	6.4957	6.4950	6 L / 11 T	6.4957	6.4948	7 L / 13 T	6.4961	6.4945	10 L / 16 T	6.4952	6.4945	2 L / 15 T
170	6.6929	6.6919	6.6926	6.6919		6.6926	6.6916		6.6929	6.6913		6.6921	6.6914	
180	7.0866	7.0856	7.0863	7.0856		7.0863	7.0853		7.0866	7.0850		7.0858	7.0851	
190	7.4803	7.4791	7.4799	7.4791		7.4800	7.4789		7.4803	7.4785		7.4793	7.4785	
200	7.8740	7.8728	7.8736	7.8728		7.8737	7.8726		7.8740	7.8722		7.8730	7.8722	
210	8.2677	8.2665	8.2673	8.2665	7 L / 12 T	8.2674	8.2663	9 L / 15 T	8.2677	8.2659	12 L / 18 T	8.2667	8.2659	2 L / 18 T
215	8.4646	8.4634	8.4641	8.4633		8.4643	8.4631		8.4646	8.4628		8.4636	8.4628	
220	8.6614	8.6602	8.6610	8.6602		8.6611	8.6600		8.6614	8.6596		8.6604	8.6596	
225	8.8583	8.8571	8.8578	8.8570		8.8580	8.8568		8.8583	8.8565		8.8573	8.8565	
230	9.0551	9.0539	9.0547	9.0539		9.0548	9.0537		9.0551	9.0533		9.0541	9.0533	
240	9.4488	9.4476	9.4484	9.4476	9 L / 14 T	9.4485	9.4474	10 L / 16 T	9.4488	9.4470	14 L / 20 T	9.4478	9.4470	3 L / 20 T
250	9.8425	9.8413	9.8421	9.8413		9.8422	9.8411		9.8425	9.8407		9.8415	9.8407	
260	10.2362	10.2348	10.2357	10.2348		10.2359	10.2346		10.2362	10.2342		10.2352	10.2343	
270	10.6299	10.6285	10.6294	10.6285		10.6296	10.6283		10.6299	10.6279		10.6289	10.6280	

BEARING OUTSIDE DIAMETER				HOUSING BORE / RESULTING FIT (0.0001")										
mm	in		M5		RESULTING FIT	M6		RESULTING FIT	M7		RESULTING FIT	N5		RESULTING FIT
	O.D.	max	min	max		min	max		min	max		min	max	
280	11.0236	11.0222	11.0231	11.0222	9 L / 14 T	11.0233	11.0220	10 L / 16 T	11.0236	11.0216	14 L / 20 T	11.0226	11.0217	3 L / 20 T
290	11.4173	11.4159	11.4168	11.4159		11.4170	11.4157		11.4173	11.4153		11.4163	11.4154	
300	11.8110	11.8096	11.8105	11.8096		11.8107	11.8094		11.8110	11.8090		11.8100	11.8091	
310	12.2047	12.2033	12.2042	12.2033		12.2044	12.2031		12.2047	12.2027		12.2037	12.2028	
320	12.5984	12.5969	12.5979	12.5969	10 L / 15 T	12.5980	12.5966	12 L / 18 T	12.5984	12.5962	16 L / 22 T	12.5972	12.5963	4 L / 22 T
340	13.3858	13.3843	13.3853	13.3843		13.3854	13.3840		13.3858	13.3836		13.3846	13.3837	
360	14.1732	14.1717	14.1727	14.1717		14.1728	14.1714		14.1732	14.1710		14.1720	14.1711	
370	14.5669	14.5654	14.5664	14.5654		14.5665	14.5651		14.5669	14.5647		14.5657	14.5648	
380	14.9606	14.9591	14.9601	14.9591		14.9602	14.9588		14.9606	14.9584		14.9594	14.9585	
400	15.7480	15.7465	15.7475	15.7465		15.7476	15.7462		15.7480	15.7458		15.7469	15.7459	
420	16.5354	16.5337	16.5348	16.5337	11 L / 17 T	16.5350	16.5335	14 L / 20 T	16.5354	16.5330	18 L / 25 T	16.5341	16.5331	5 L / 24 T
440	17.3228	17.3211	17.3222	17.3211		17.3224	17.3209		17.3228	17.3204		17.3215	17.3205	
460	18.1102	18.1085	18.1096	18.1085		18.1098	18.1083		18.1102	18.1078		18.1089	18.1079	
480	18.8976	18.8959	18.8970	18.8959		18.8972	18.8957		18.8976	18.8952		18.8963	18.8953	
500	19.6850	19.6833	19.6844	19.6833	11 L / 17 T	19.6846	19.6831	14 L / 20 T	19.6850	19.6826	18 L / 25 T	19.6837	19.6827	5 L / 24 T
520	20.4724	20.4705	--	--		20.4714	20.4697		20.4714	20.4687		--	--	
540	21.2598	21.2579	--	--		21.2588	21.2571		21.2588	21.2561		--	--	
560	22.0472	22.0453	--	--		22.0462	22.0445		22.0462	22.0435		--	--	
580	22.8346	22.8327	--	--		22.8336	22.8319		22.8336	22.8309		--	--	
600	23.6220	23.6201	--	--		23.6210	23.6193		23.6210	23.6183		--	--	
620	24.4094	24.4075	--	--		24.4084	24.4067		24.4084	24.4057		--	--	
650	25.5906	25.5876	--	--		25.5894	25.5874		25.5894	25.5862		--	--	
670	26.3780	26.3750	--	--		26.3768	26.3748		26.3768	26.3736		--	--	
680	26.7717	26.7687	--	--		26.7705	26.7685		26.7705	26.7673		--	--	
700	27.5591	27.5561	--	--	27.5579	27.5559	27.5579	27.5547	--	--				
720	28.3465	28.3435	--	--	28.3453	28.3433	28.3453	28.3421	--	--				
750	29.5276	29.5246	--	--	29.5264	29.5244	29.5264	29.5232	--	--				
760	29.9213	29.9183	--	--	29.9201	29.9181	29.9201	29.9169	--	--				
780	30.7087	30.7057	--	--	30.7075	30.7055	30.7075	30.7043	--	--				
790	31.1024	31.0994	--	--	31.1012	31.0992	31.1012	31.0980	--	--				
800	31.4961	31.4931	--	--	31.4949	31.4929	31.4949	31.4917	--	--				
820	32.2835	32.2795	--	--	32.2821	32.2799	32.2821	32.2786	--	--				
830	32.6772	32.6732	--	--	32.6758	32.6736	32.6758	32.6723	--	--				
850	33.4646	33.4606	--	--	33.4632	33.4610	33.4632	33.4597	--	--				
870	34.2520	34.2480	--	--	34.2506	34.2484	34.2506	34.2471	--	--				
920	36.2205	36.2165	--	--	36.2191	36.2169	36.2191	36.2156	--	--				
950	37.4016	37.3976	--	--	37.4002	37.3980	37.4002	37.3967	--	--				
980	38.5827	38.5787	--	--	38.5813	38.5791	38.5813	38.5778	--	--				
1000	39.3701	39.3661	--	--	39.3687	39.3665	39.3687	39.3652	--	--				
1150	45.2756	45.2707	--	--	45.2740	45.2714	45.2740	45.2699	--	--				
1250	49.2126	49.2077	--	--	49.2110	49.2084	49.2110	49.2069	--	--				
1400	55.1181	55.1118	--	--	55.1162	55.1131	55.1162	55.1113	--	--				
1600	62.9921	62.9858	--	--	62.9902	62.9872	62.9902	62.9853	--	--				
1800	70.8661	70.8583	--	--	70.8639	70.8602	70.8639	70.8580	--	--				
2000	78.7402	78.7323	--	--	78.7379	78.7343	78.7379	78.7320	--	--				
2300	90.5512	90.5413	--	--	90.5485	90.5442	90.5485	90.5416	--	--				
2500	98.4252	98.4154	--	--	98.4225	98.4182	98.4225	98.4156	--	--				

HOUSING BEARING-SEAT DIAMETERS

Table 13 - Housing Bore Diameters and Resulting Fits

Units: inch

BEARING OUTSIDE DIAMETER			HOUSING BORE / RESULTING FIT (0.0001")											
mm	in		N6		RESULTING FIT	N7		RESULTING FIT	P6		RESULTING FIT	P7		RESULTING FIT
O.D.	max	min	max	min		max	min		max	min		max	min	
16	0.6299	0.6296	0.6296	0.6291	0 T / 8 T	0.6297	0.6290	1 L / 9 T	0.6293	0.6289	3 T / 10 T	0.6295	0.6288	1 T / 11 T
19	0.7480	0.7477	0.7476	0.7471	1 T / 9 T	0.7478	0.7469	1 L / 11 T	0.7473	0.7468	4 T / 12 T	0.7475	0.7467	2 T / 14 T
22	0.8661	0.8658	0.8657	0.8652		0.8659	0.8650		0.8654	0.8649		0.8656	0.8648	
24	0.9449	0.9445	0.9444	0.9439		0.9446	0.9438		0.9442	0.9437		0.9443	0.9435	
26	1.0236	1.0233	1.0232	1.0227		1.0233	1.0225		1.0229	1.0224		1.0231	1.0222	
28	1.1024	1.1020	1.1019	1.1014		1.1021	1.1013		1.1017	1.1011		1.1018	1.1010	
30	1.1811	1.1807	1.1807	1.1802	0 T / 11 T	1.1808	1.1800	1 L / 13 T	1.1804	1.1799	4 T / 15 T	1.1806	1.1797	2 T / 17 T
32	1.2598	1.2594	1.2594	1.2587		1.2595	1.2585		1.2590	1.2584		1.2592	1.2582	
35	1.3780	1.3775	1.3775	1.3769		1.3776	1.3767		1.3771	1.3765		1.3773	1.3763	
37	1.4567	1.4563	1.4562	1.4556		1.4564	1.4554		1.4559	1.4552		1.4560	1.4550	
40	1.5748	1.5744	1.5743	1.5737		1.5745	1.5735		1.5740	1.5733		1.5741	1.5731	
42	1.6535	1.6531	1.6531	1.6524	0 T / 13 T	1.6532	1.6522	2 L / 15 T	1.6527	1.6521	5 T / 18 T	1.6529	1.6519	3 T / 20 T
47	1.8504	1.8500	1.8499	1.8493		1.8501	1.8491		1.8496	1.8489		1.8497	1.8487	
52	2.0472	2.0467	2.0467	2.0459		2.0469	2.0457		2.0462	2.0455		2.0464	2.0452	
55	2.1654	2.1648	2.1648	2.1641		2.1650	2.1638		2.1643	2.1636		2.1645	2.1633	
62	2.4409	2.4404	2.4404	2.4396		2.4406	2.4394		2.4399	2.4392		2.4401	2.4389	
68	2.6772	2.6767	2.6766	2.6759	0 T / 15 T	2.6768	2.6756	2 L / 18 T	2.6761	2.6754	6 T / 20 T	2.6763	2.6752	4 T / 23 T
72	2.8346	2.8341	2.8341	2.8333		2.8343	2.8331		2.8336	2.8329		2.8338	2.8326	
75	2.9528	2.9522	2.9522	2.9515		2.9524	2.9512		2.9517	2.9510		2.9519	2.9507	
80	3.1496	3.1491	3.1491	3.1483		3.1493	3.1481		3.1486	3.1478		3.1488	3.1476	
85	3.3465	3.3459	3.3458	3.3450		3.3461	3.3447		3.3453	3.3444		3.3455	3.3441	
90	3.5433	3.5427	3.5427	3.5418	1 T / 18 T	3.5429	3.5415	2 L / 20 T	3.5421	3.5413	7 T / 24 T	3.5424	3.5410	4 T / 27 T
95	3.7402	3.7396	3.7395	3.7387		3.7398	3.7384		3.7390	3.7381		3.7392	3.7378	
100	3.9370	3.9364	3.9364	3.9355		3.9366	3.9352		3.9358	3.9350		3.9361	3.9347	
110	4.3307	4.3301	4.3301	4.3292		4.3303	4.3289		4.3295	4.3287		4.3298	4.3284	
115	4.5276	4.5270	4.5269	4.5261		4.5272	4.5258		4.5264	4.5255		4.5266	4.5252	
120	4.7244	4.7238	4.7238	4.7229	2 L / 18 T	4.7240	4.7226	5 L / 20 T	4.7232	4.7224	4 T / 24 T	4.7235	4.7221	1 T / 27 T
125	4.9213	4.9206	4.9205	4.9195		4.9208	4.9192		4.9198	4.9189		4.9202	4.9186	
130	5.1181	5.1174	5.1173	5.1163		5.1176	5.1161		5.1167	5.1157		5.1170	5.1154	
140	5.5118	5.5111	5.5110	5.5100		5.5113	5.5098		5.5104	5.5094		5.5107	5.5091	
145	5.7087	5.7080	5.7079	5.7069		5.7082	5.7066		5.7072	5.7063		5.7076	5.7060	
150	5.9055	5.9048	5.9047	5.9037	2 L / 18 T	5.9050	5.9035	6 L / 24 T	5.9041	5.9031	4 T / 28 T	5.9044	5.9028	1 T / 31 T
160	6.2992	6.2982	6.2984	6.2974		6.2987	6.2972		6.2978	6.2968		6.2981	6.2965	
165	6.4961	6.4951	6.4953	6.4943		6.4956	6.4940		6.4946	6.4937		6.4950	6.4934	
170	6.6929	6.6919	6.6921	6.6911		6.6924	6.6909		6.6915	6.6905		6.6918	6.6902	
180	7.0866	7.0856	7.0858	7.0848		7.0861	7.0846		7.0852	7.0842		7.0855	7.0839	
190	7.4803	7.4791	7.4794	7.4783	3 L / 20 T	7.4798	7.4780	8 L / 26 T	7.4787	7.4776	5 T / 31 T	7.4790	7.4772	0 T / 35 T
200	7.8740	7.8728	7.8731	7.8720		7.8735	7.8717		7.8724	7.8713		7.8727	7.8709	
210	8.2677	8.2665	8.2669	8.2657		8.2672	8.2654		8.2661	8.2650		8.2664	8.2646	
215	8.4646	8.4634	8.4637	8.4626		8.4640	8.4622		8.4630	8.4618		8.4633	8.4615	
220	8.6614	8.6602	8.6606	8.6594		8.6609	8.6591		8.6598	8.6587		8.6601	8.6583	
225	8.8583	8.8571	8.8574	8.8563	4 L / 22 T	8.8577	8.8559	8 L / 26 T	8.8567	8.8555	5 T / 31 T	8.8570	8.8552	0 T / 35 T
230	9.0551	9.0539	9.0543	9.0531		9.0546	9.0528		9.0535	9.0524		9.0538	9.0520	
240	9.4488	9.4476	9.4480	9.4468		9.4483	9.4465		9.4472	9.4461		9.4475	9.4457	
250	9.8425	9.8413	9.8417	9.8405		9.8420	9.8402		9.8409	9.8398		9.8412	9.8394	
260	10.2362	10.2348	10.2352	10.2340		10.2357	10.2336		10.2344	10.2331		10.2348	10.2328	
270	10.6299	10.6285	10.6289	10.6277	10.6294	10.6273	10.6281	10.6268	10.6285	10.6265				

BEARING OUTSIDE DIAMETER			HOUSING BORE / RESULTING FIT (0.0001")											
mm	in		N6		RESULTING FIT	N7		RESULTING FIT	P6		RESULTING FIT	P7		RESULTING FIT
	O.D.	max	min	max		min	max		min	max		min	max	
280	11.0236	11.0222	11.0226	11.0214	4 L / 22 T	11.0231	11.0210	8 L / 26 T	11.0218	11.0205	5 T / 31 T	11.0222	11.0202	0 T / 35 T
290	11.4173	11.4159	11.4163	11.4151		11.4168	11.4147		11.4155	11.4142		11.4159	11.4139	
300	11.8110	11.8096	11.8100	11.8088		11.8105	11.8084		11.8092	11.8079		11.8096	11.8076	
310	12.2047	12.2033	12.2037	12.2025		12.2042	12.2021		12.2029	12.2016		12.2033	12.2013	
320	12.5984	12.5969	12.5974	12.5960	6 L / 24 T	12.5978	12.5956	9 L / 29 T	12.5964	12.5950	4 T / 34 T	12.5968	12.5946	0 T / 39 T
340	13.3858	13.3843	13.3848	13.3834		13.3852	13.3830		13.3838	13.3824		13.3842	13.3820	
360	14.1732	14.1717	14.1722	14.1708		14.1726	14.1704		14.1712	14.1698		14.1716	14.1694	
370	14.5669	14.5654	14.5659	14.5645		14.5663	14.5641		14.5649	14.5635		14.5653	14.5631	
380	14.9606	14.9591	14.9596	14.9582		14.9600	14.9578		14.9586	14.9572		14.9590	14.9568	
400	15.7480	15.7465	15.7470	15.7456	15.7474	15.7452	15.7460	15.7446	15.7464	15.7442				
420	16.5354	16.5337	16.5344	16.5328	7 L / 26 T	16.5348	16.5323	11 L / 31 T	16.5333	16.5317	4 T / 37 T	16.5337	16.5312	0 T / 43 T
440	17.3228	17.3211	17.3218	17.3202		17.3222	17.3197		17.3207	17.3191		17.3211	17.3186	
460	18.1102	18.1085	18.1092	18.1076		18.1096	18.1071		18.1081	18.1065		18.1085	18.1060	
480	18.8976	18.8959	18.8966	18.8950		18.8970	18.8945		18.8955	18.8939		18.8959	18.8934	
500	19.6850	19.6833	19.6840	19.6824	2 L / 35 T	19.6844	19.6819	2 L / 45 T	19.6829	19.6813	11 T / 48 T	19.6833	19.6808	11 T / 58 T
520	20.4724	20.4705	20.4707	20.4690		20.4707	20.4680		20.4694	20.4676		20.4694	20.4666	
540	21.2598	21.2579	21.2581	21.2564		21.2581	21.2554		21.2568	21.2550		21.2568	21.2540	
560	22.0472	22.0453	22.0455	22.0438		22.0455	22.0428		22.0442	22.0424		22.0442	22.0414	
580	22.8346	22.8327	22.8329	22.8312		22.8329	22.8302		22.8316	22.8298		22.8316	22.8288	
600	23.6220	23.6201	23.6203	23.6186		23.6203	23.6176		23.6190	23.6172		23.6190	23.6162	
620	24.4094	24.4075	24.4077	24.4060		24.4077	24.4050		24.4064	24.4046		24.4064	24.4036	
650	25.5906	25.5876	25.5886	25.5866	10 L / 39 T	25.5886	25.5854	10 L / 51 T	25.5871	25.5851	5 T / 54 T	25.5871	25.5839	5 T / 66 T
670	26.3780	26.3750	26.3760	26.3740		26.3760	26.3728		26.3745	26.3725		26.3745	26.3713	
680	26.7717	26.7687	26.7697	26.7677		26.7697	26.7665		26.7682	26.7662		26.7682	26.7650	
700	27.5591	27.5561	27.5571	27.5551		27.5571	27.5539		27.5556	27.5536		27.5556	27.5524	
720	28.3465	28.3435	28.3445	28.3425		28.3445	28.3413		28.3430	28.3410		28.3430	28.3398	
750	29.5276	29.5246	29.5256	29.5236		29.5256	29.5224		29.5241	29.5221		29.5241	29.5209	
760	29.9213	29.9183	29.9193	29.9173		29.9193	29.9161		29.9178	29.9158		29.9178	29.9146	
780	30.7087	30.7057	30.7067	30.7047		30.7067	30.7035		30.7052	30.7032		30.7052	30.7020	
790	31.1024	31.0994	31.1004	31.0984		31.1004	31.0972		31.0989	31.0969		31.0989	31.0957	
800	31.4961	31.4931	31.4941	31.4921		31.4941	31.4909		31.4926	31.4906		31.4926	31.4894	
820	32.2835	32.2795	32.2813	32.2791	17 L / 44 T	32.2813	32.2777	17 L / 57 T	32.2795	32.2773	0 T / 61 T	32.2795	32.2760	0 T / 75 T
830	32.6772	32.6732	32.6750	32.6728		32.6750	32.6714		32.6732	32.6710		32.6732	32.6697	
850	33.4646	33.4606	33.4624	33.4602		33.4624	33.4588		33.4606	33.4584		33.4606	33.4571	
870	34.2520	34.2480	34.2498	34.2476		34.2498	34.2462		34.2480	34.2458		34.2480	34.2445	
920	36.2205	36.2165	36.2183	36.2161		36.2183	36.2147		36.2165	36.2143		36.2165	36.2130	
950	37.4016	37.3976	37.3994	37.3972		37.3994	37.3958		37.3976	37.3954		37.3976	37.3941	
980	38.5827	38.5787	38.5805	38.5783		38.5805	38.5769		38.5787	38.5765		38.5787	38.5752	
1000	39.3701	39.3661	39.3679	39.3657	39.3679	39.3643	39.3661	39.3639	39.3661	39.3626				
1150	45.2756	45.2707	45.2730	45.2704	23 L / 52 T	45.2730	45.2689	23 L / 67 T	45.2709	45.2683	2 L / 73 T	45.2709	45.2667	2 L / 89 T
1250	49.2126	49.2077	49.2100	49.2074		49.2100	49.2059		49.2079	49.2053		49.2079	49.2037	
1400	55.1181	55.1118	55.1150	55.1120	32 L / 61 T	55.1150	55.1101	32 L / 80 T	55.1126	55.1095	8 L / 86 T	55.1126	55.1077	8 L / 104 T
1600	62.9921	62.9858	62.9891	62.9860		62.9891	62.9841		62.9866	62.9835		62.9866	62.9817	
1800	70.8661	70.8583	70.8625	70.8589	43 L / 72 T	70.8625	70.8566	43 L / 95 T	70.8594	70.8558	12 L / 103 T	70.8594	70.8535	12 L / 126 T
2000	78.7402	78.7323	78.7365	78.7329		78.7365	78.7306		78.7335	78.7298		78.7335	78.7276	
2300	90.5512	90.5413	90.5469	90.5425	55 L / 87 T	90.5469	90.5400	55 L / 112 T	90.5435	90.5392	22 L / 120 T	90.5435	90.5366	22 L / 146 T
2500	98.4252	98.4154	98.4209	98.4165		98.4209	98.4140		98.4175	98.4132		98.4175	98.4106	

TOLERANCE GRADES IT

Table 14 - Values of Normal Tolerance Grades IT

BASIC SIZE (MM)		IT1	IT2	IT3	IT4	IT5	IT6	IT7	IT8	IT9
Over	incl	Tolerances (inch)								
--	3	0.00003	0.00005	0.00008	0.00012	0.00016	0.00024	0.00039	0.00055	0.00098
3	6	0.00004	0.00006	0.00010	0.00016	0.00020	0.00032	0.00047	0.00071	0.00118
6	10	0.00004	0.00006	0.00010	0.00016	0.00024	0.00035	0.00059	0.00087	0.00142
10	18	0.00005	0.00008	0.00012	0.00020	0.00032	0.00043	0.00071	0.00106	0.00169
18	30	0.00006	0.00010	0.00016	0.00024	0.00035	0.00051	0.00083	0.00130	0.00205
30	50	0.00006	0.00010	0.00016	0.00028	0.00043	0.00063	0.00098	0.00154	0.00244
50	80	0.00008	0.00012	0.00020	0.00032	0.00051	0.00075	0.00118	0.00181	0.00291
80	120	0.00010	0.00016	0.00024	0.00039	0.00059	0.00087	0.00138	0.00213	0.00343
120	180	0.00014	0.00020	0.00032	0.00047	0.00071	0.00098	0.00158	0.00248	0.00394
180	250	0.00018	0.00028	0.00039	0.00055	0.00079	0.00114	0.00181	0.00284	0.00453
250	315	0.00024	0.00032	0.00047	0.00063	0.00091	0.00126	0.00205	0.00319	0.00512
315	400	0.00028	0.00035	0.00051	0.00071	0.00098	0.00142	0.00224	0.00350	0.00551
400	500	0.00032	0.00039	0.00059	0.00079	0.00106	0.00158	0.00248	0.00382	0.00610
500	630	--	--	--	--	--	0.00173	0.00276	0.00433	0.00689
630	800	--	--	--	--	--	0.00197	0.00315	0.00492	0.00787
800	1000	--	--	--	--	--	0.00221	0.00354	0.00551	0.00906
1000	1250	--	--	--	--	--	0.00260	0.00413	0.00650	0.01024
1250	1600	--	--	--	--	--	0.00307	0.00492	0.00768	0.01221
1600	2000	--	--	--	--	--	0.00362	0.00591	0.00906	0.01457
2000	2500	--	--	--	--	--	0.00433	0.00689	0.01102	0.01732
2500	3150	--	--	--	--	--	0.00532	0.00827	0.01299	0.02126

IT10	IT11	IT12	IT13	IT14	IT15	IT16	IT17	IT18	BASIC SIZE (MM)	
Tolerances (inch)									Over	incl
0.00158	0.00236	0.00394	0.00551	0.00984	0.01575	0.02362	0.03937	0.05512	--	3
0.00189	0.00295	0.00472	0.00709	0.01181	0.01890	0.02953	0.04724	0.07087	3	6
0.00228	0.00354	0.00591	0.00866	0.01417	0.02284	0.03543	0.05906	0.08661	6	10
0.00276	0.00433	0.00709	0.01063	0.01693	0.02756	0.04331	0.07087	0.10630	10	18
0.00331	0.00512	0.00827	0.01299	0.02047	0.03307	0.05118	0.08268	0.12992	18	30
0.00394	0.00630	0.00984	0.01535	0.02441	0.03937	0.06299	0.09843	0.15354	30	50
0.00472	0.00748	0.01181	0.01811	0.02913	0.04724	0.07480	0.11811	0.18110	50	80
0.00551	0.00866	0.01378	0.02126	0.03425	0.05512	0.08661	0.13780	0.21260	80	120
0.00630	0.00984	0.01575	0.02480	0.03937	0.06299	0.09843	0.15748	0.24803	120	180
0.00728	0.01142	0.01811	0.02835	0.04528	0.07284	0.11417	0.18110	0.28347	180	250
0.00827	0.01260	0.02047	0.03189	0.05118	0.08268	0.12598	0.20472	0.31890	250	315
0.00906	0.01417	0.02244	0.03504	0.05512	0.09055	0.14173	0.22441	0.35039	315	400
0.00984	0.01575	0.02480	0.03819	0.06102	0.09843	0.15748	0.24803	0.38189	400	500
0.01102	0.01732	0.02756	0.04331	0.06890	0.11024	0.17323	0.27559	0.43307	500	630
0.01260	0.01969	0.03150	0.04921	0.07874	0.12598	0.19685	0.31496	0.49213	630	800
0.01417	0.02205	0.03543	0.05512	0.09055	0.14173	0.22047	0.35433	0.55118	800	1000
0.01654	0.02598	0.04134	0.06496	0.10236	0.16535	0.25984	0.41339	0.64961	1000	1250
0.01969	0.03071	0.04921	0.07677	0.12205	0.19685	0.30709	0.49213	0.76772	1250	1600
0.02362	0.03622	0.05906	0.09055	0.14567	0.23622	0.36221	0.59055	0.90551	1600	2000
0.02756	0.04331	0.06890	0.11024	0.17323	0.27559	0.43307	0.68898	1.10236	2000	2500
0.03386	0.05315	0.08268	0.12992	0.21260	0.33858	0.53150	0.82677	1.29921	2500	3150



The background of the left side of the page features a dark, monochromatic image of mechanical gears and a splash of oil, creating a technical and industrial atmosphere.

SECTION D: LUBRICATION

GENERAL INFORMATION	D3
SELECTING THE CORRECT LUBRICATION METHOD	D4
LUBRICATING GREASE	D5
Properties	D5
Additives	D5
Consistency	D5
Oil Separation Rate	D5
Rust / Corrosion Protection	D7
Mixing Greases	D7
Grease Quantity	D7
Grease Replacement	D7
Replenishment Interval / Adjustments	D8
LUBRICATING OIL	D11
Properties	D11
Recommended Viscosities	D11
Comparative Viscosity Classifications	D11
Oil Temperature and Viscosity	D12
Selecting Lubricating Oils	D13
Methods of Oil Lubrication	D13
Oil Bath	D13
Drip Feed	D14
Splash	D14
Circulating System	D14
Jet	D15
Oil Mist	D15
Oil / Air	D16
Oil Replacement Intervals	D16
Mixing Oils	D16
MOLDED-OIL AND SOLID LUBE OPTIONS	D17

LUBRICATION

Lubrication is essential to bearings to achieve the level of performance for which they were designed. Appropriate lubricant selection and methods employed will ensure reduced friction and wear inside the bearing, while allowing the bearing to perform optimally for the duration of its expected life. Primarily, lubrication serves the following purposes:

Reduction of Friction and Wear

Direct metallic contact between the bearing rings, rolling elements and cage is prevented by an oil film which reduces the friction and heat at the contact areas.

Extends Bearing Life

The rolling fatigue life of bearings depends in a large part on the viscosity and film thickness of the lubricant. A proper film thickness prolongs the bearing fatigue life.

Cooling

Circulating oil can be used to carry heat away from the bearing. A circulating system is normally used when excessive heat is generated by the bearing due to high speeds, high loads, or when heat from a source adjacent to the bearing can affect its operation. Oils deteriorate at high temperatures; therefore it is important to keep both the oil and the bearing cool.

Other Purposes

Proper lubrication also helps to prevent foreign material from entering the bearings, and protects against corrosion or rusting.

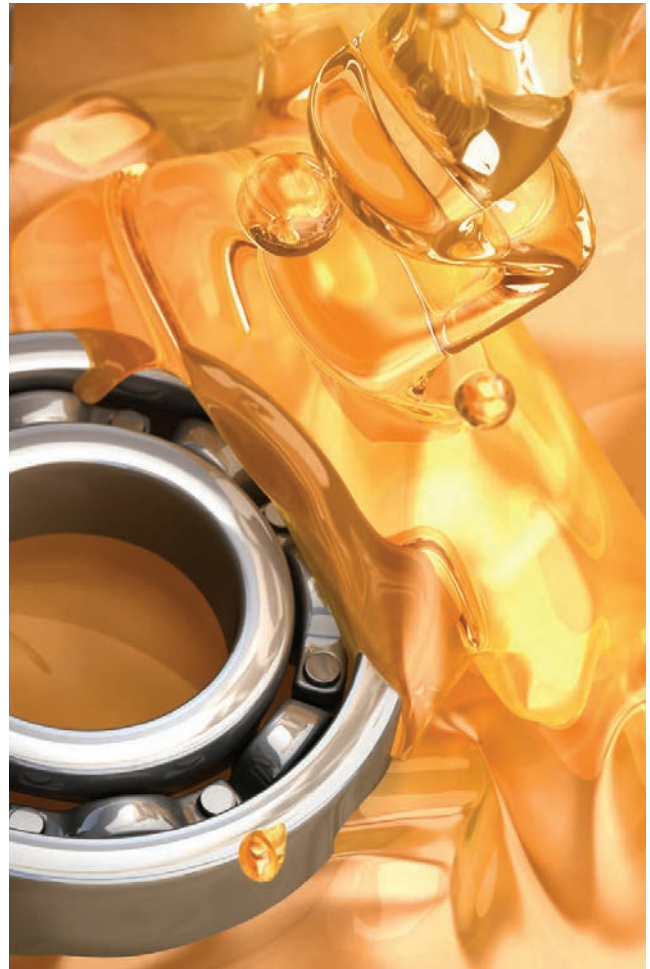

SELECTING THE CORRECT LUBRICATION METHOD

Lubrication can be accomplished by using either oil or grease. The most satisfactory bearing performance will be achieved by selecting the method most suitable for a specific application. This of course will also depend on the conditions under which the bearing will operate.

Oil lubrication is superior in lubricating efficiency; however, grease lubrication allows a simpler structure around the bearings.

Table 1 illustrates the basic operating conditions to be considered, and the relative suitability of oil and grease lubrication.

Table 1 - Grease vs. Oil Lubrication

OPERATING FACTOR	GREASE LUBRICATION	OIL LUBRICATION
Housing Structure and Sealing Method	Simple	May be complex. Careful maintenance required.
Speed	Limiting speed is 65 % to 80% that of oil lubrication	High limiting speed
Cooling Effect	Poor	Heat transfer is possible using forced oil circulation lubrication
Fluidity	Poor	Good
Full Lubrication Replacement	Sometimes difficult	Easy
Removal of Foreign Matter	Impossible	Easy
External Contamination Due to Leakage	Surroundings seldom contaminated by leakage	Often leaks without proper countermeasures. Not suitable if external contamination must be avoided.

GREASE LUBRICATION

LUBRICATING GREASE

Grease is a semi-solid lubricant consisting of a base oil and a thickener. Other ingredients are sometimes added to impart special properties to the base. The main types and general properties of grease are shown in **Table 2**. It should be noted that different brands of the same type of grease may have different properties.

› Base Oil

Mineral oil or synthetic oils such as silicon or diester oil, are commonly used as the base oil for grease. The lubricating properties of grease are dependent on the characteristics of its base oil. The viscosity of the base oil is an important consideration when selecting grease. Usually grease made with a low viscosity base oil is more suitable for high speeds and low temperatures while grease made with high viscosity base oils is more suited for high temperatures and heavy loads. The thickener also influences the lubricating properties of grease, therefore selection criteria for grease are not the same as for lubricating oil.

› Thickener

Several types of metallic soaps, inorganic compounds such as silica gel and bentonite, and heat resisting organic thickeners such as polyurea and flouric compounds are used as thickeners for grease. The water resistance properties of grease depend on the type of thickener. Sodium soap grease (or compound grease containing sodium soap) emulsifies when exposed to water or high humidity and therefore cannot be used where moisture is prevalent. Lithium soap grease, on the other hand, is recommended where moisture is present because of its resistance to wash off.

For applications where the operating temperature exceeds the limitation of common multi-purpose grease, greases having complex bases or non-soap bases are recommended. The grease used should also have a synthetic oil to withstand rapid deterioration at high temperatures. If the grease used in a high temperature application uses a mineral oil, it should be replenished frequently as deterioration of the oil will be accelerated at high temperatures.

ADDITIVES

Grease often contains a variety of additives such as antioxidants, corrosion inhibitors, and extreme pressure additives to give it special properties. Extreme pressure additives are recommended for use in heavy load applications. For long use without replenishment, an antioxidant should be added.

In heavy load or slow rotating applications, bearing life is a function of keeping the lubricant film thickness sufficient to separate the rolling elements from the raceway surface. In these cases lubricants with Extreme Pressure (EP) and Anti-Wear (AW) additives are used. As lubricant film thickness is also a function of temperature, careful consideration of the operating temperature is recommended to ensure use of the appropriate additive. AW additives are similar to EP additives in that their function is to prevent metal on metal contact by building up a protective layer on the surfaces. Some lubricants, intended for very low speed operation, include solid additives such as graphite or molybdenum disulphide (MoS₂), and should be considered carefully as these particles may reduce bearing fatigue life.

CONSISTENCY

Consistency indicates the “softness” of the grease. **Table 3** shows the relationship between consistency and working conditions.

OIL SEPARATION RATE

During the normal operation of bearings with grease lubrication a small amount of oil is released. The rate at which this oil is released is referred to as the oil separation rate, or oil bleed rate. It is determined by testing, as described in JIS K2220 (5.7) or DIN 51817, and is expressed as a percentage. Typical oil separation rates fall in the range of 1% to 5%. Actual oil separation varies as it is a function of the base oil viscosity, the thickener type and amount, temperature, other additives and the processing.

Table 2 - Grease Properties

POPULAR NAME	Lithium Grease			Sodium Grease (Fiber Grease)	Calcium Grease (Cup Grease)	Mixed Base Grease	Complex Grease	Non-Soap Base Grease	
THICKENER	Li soap			Na soap	Ca soap	Na + Ca soap, Li + Ca soap, etc.	Ca complex, Al complex, etc.	Silica gel, bentonite, carbon black, polyurea, fluoric compounds, heat resistant organic compound, etc.	
BASE OIL	Mineral Oil	Diester Oil	Silicone Oil	Mineral Oil	Mineral Oil	Mineral Oil	Mineral Oil	Mineral Oil	Synthetic Oil
Dropping Point (°C)	170 to 190	170 to 195	200 to 210	170 to 210	70 to 90	160 to 190	180 to 300	230	240 and above
Working Temp. (°C)	-20 to 110	-50 to 130	-50 to 160	-20 to 130	-20 to 60	-20 to 80	-20 to 130	-10 to 130	up to 250
Working Speed® (%)	70	100	60	70	40	70	70	70	40 to 100
Mechanical Stability	Good	Good	Good	Good	Poor	Good	Good	Good	Good
Pressure Resistance	Fair	Fair	Poor	Fair	Poor	Fair to Good	Fair to Good	Fair	Fair
Water Resistance	Good	Good	Good	Poor	Good	Poor for Na soap	Good	Good	Good
Rust Prevention	Good	Good	Poor	Poor to Good	Good	Fair to Good	Fair to Good	Fair to Good	Fair to Good
Comments	General purpose lubricant	Good low temperature and torque characteristics. Often used for small motor and instrument bearings.	Mainly for high temperature applications. Unsuitable for bearings under high speed or heavy load conditions or for sliding contact areas (roller bearings).	Long and short fiber types available. Long fiber grease is not suitable for high speeds or for sliding contact areas (roller bearings).	Not suitable for high temp. and heavy loads. Extreme pressure grease containing high viscosity oil and extreme pressure additive (Pb soap, etc.) is available.	Often used for roller bearings and large ball bearings.	Suitable for extreme pressures. Mechanically stable.	Medium and high temperature lubricant.	Recommended for special environments with very high and low temperatures, acids, alkalis, radioactivity, and exposure to flames.

Table 3 - Grease Consistency

	CONSISTENCY NUMBER (NLGI SCALE)				
	0	1	2	3	4
Consistency (1/10 mm)	385 - 355	340 - 310	295 - 265	250 - 220	205 - 175
Working Condition	For centralized oiling. When false brinelling is liable to occur.	For centralized oiling. When fretting is liable to occur. For low temperature.	For general use. For sealed bearings.	For high temperature. For general use. For sealed bearings.	For high temperature. For grease seals.

Note: Consistency - depth into grease attained by a cone when pressed with a specified weight, indicated in units of 1/10 mm. The larger the value, the softer the grease.

GREASE LUBRICATION

RUST / CORROSION PROTECTION

Lithium complex, calcium complex and polyurea greases are typically considered to be good against wash out by water. No grease, however, is completely water resistant. The rate of ingress of water or wash out of the grease can be controlled somewhat by the grease fill amount, the relubrication interval, and the exposure to large volumes of water in the application.

MIXING GREASES

In general, grease of different types must not be mixed. Mixing grease with different types of thickeners may destroy the composition and physical properties of the grease. Even if the thickeners are of the same type, possible differences in the additives may cause detrimental effects.

GREASE QUANTITY

The quantity of grease to be packed in a housing depends on the housing design, grease characteristics, and ambient temperature. The bearings for the main spindle of machine tools - for example - where the accuracy may be impaired by a small temperature rise, require only a small amount of grease to reduce friction and heat.

Sufficient grease must be packed inside the bearing including on the cage guide surfaces. The amount of space inside the bearing and housing to be packed with grease depends upon the speed, as follows:

1/2 to 2/3 of the space - when the speed is less than 50% of the limiting speed

1/3 to 1/2 of the space - when the speed is more than 50% of the limiting speed

This is a general guideline for initial grease fill. It is important to carefully monitor bearing operating temperatures and adjust the grease fill accordingly. To determine the free space inside a specific bearing type contact your NSK application engineer.

GREASE REPLACEMENT

Typically, once a bearing and housing are properly packed with grease, replacement isn't necessary for an extended period. In applications with severe operating conditions, such as heavy loads, high speeds and/or elevated temperatures, grease should be replaced more frequently as grease deterioration is accelerated. In such cases, the bearing housing should be designed to facilitate grease replenishment and replacement. When replenishment intervals are short, provide replenishment and discharge ports at appropriate positions so deteriorated grease is replaced by fresh grease. For example, the housing space on the grease supply side can be divided into several sections with partitions. The grease on the partitioned side gradually passes through the bearings and old grease forced from the bearing is discharged through a grease valve (**Figure 1**). If a grease valve is not used, the space on the discharge side is made larger than the partitioned side so it can retain the old grease, which is removed periodically by removing the cover.

Fig. 1 – Combination of Partitioned Grease Reservoir and Grease Valve

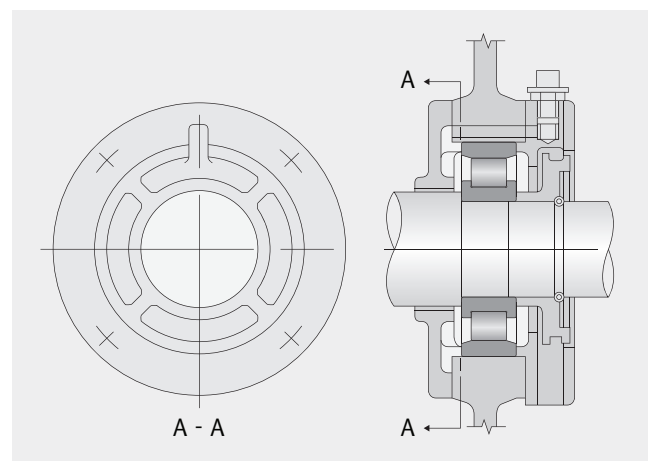

REPLENISHMENT INTERVAL

Even if high-quality grease is used, there is deterioration of its properties with time; therefore, periodic replenishment is required. **Figure 2** and **Figure 3** show the replenishment time intervals (in hours) for various bearing types running at different speeds, and applies to bearings lubricated with high-quality lithium soap-mineral oil grease, bearing temperature of 70°C (158°F) and normal load ($P/C = 0.06$ to 0.13).

REPLENISHMENT INTERVAL ADJUSTMENTS

For conditions other than those used to create **Figures 2** and **3**, adjustments may be made. Adjustments due to varied conditions can be compared to the results from **Figures 2** and **3**.

Bearing Load

For conditions where P/C varies from 10% of the dynamic load rating multiply the load factor from **Figure 4** by the result from **Figures 2** and **3**.

P = Applied Equivalent Bearing Load

C = Bearing Dynamic Load Rating

Where P/C exceeds 0.16 it is recommended that you consult with NSK engineering.

Fig. 4 - Load factor

P/C	≤ 0.06	0.10	0.13	0.16
Load Factor	1.50	1.00	0.65	0.45

Temperature

If the bearing temperature exceeds 70°C (158°F), the replenishment time interval must be reduced by half for every 15°C (27°F) bearing temperature increase.

Fig. 2 - Grease Replenishment Intervals for Radial Ball Bearings and Cylindrical Roller Bearings

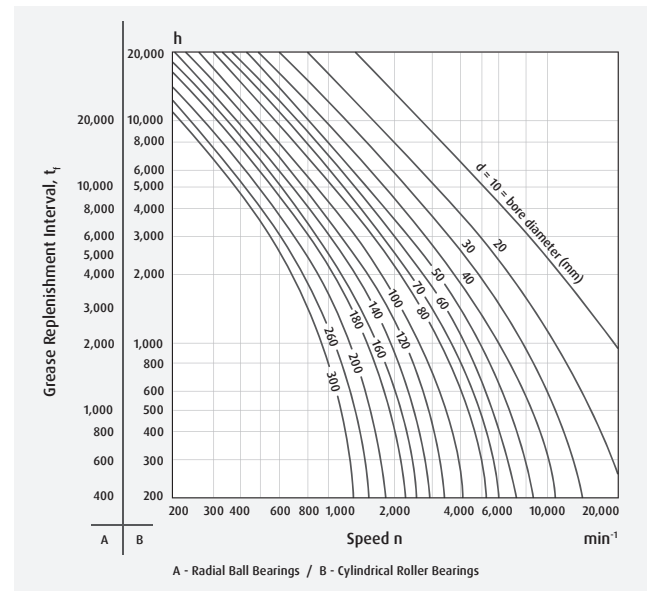
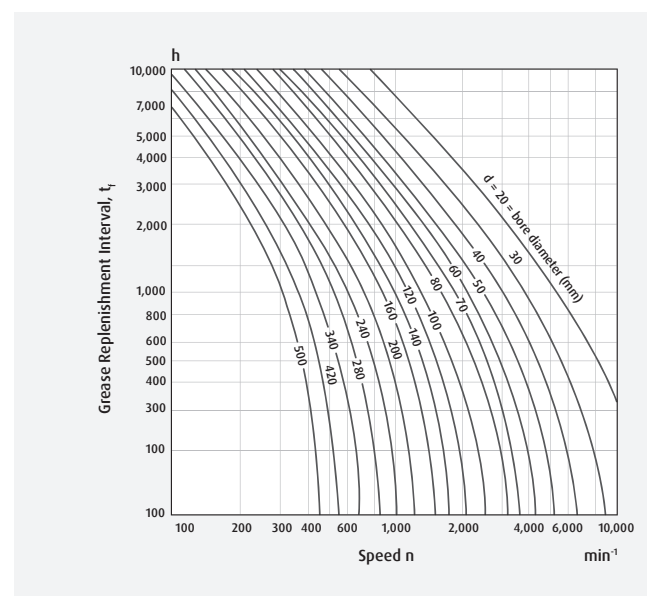

Fig. 3 - Grease Replenishment Intervals for Tapered Roller Bearings and Spherical Roller Bearings



GREASE LUBRICATION

REPLENISHMENT INTERVAL ADJUSTMENTS

Grease Type

In case of ball bearings especially, the replenishing interval can be extended depending on the grease type used. (For example, high-quality lithium soap synthetic oil grease may extend the replenishment time interval shown in **Figure 2** and **Figure 3** on **page D8** by two times.) The information provided is considered a general purpose guideline. Lubrication properties can vary significantly with a multitude of various operating conditions, of which, only a few are discussed in this document. It is advisable to consult with NSK engineering or lubrication manufacturer for questions about a particular grease life expectation.

High Speeds

Relubrication intervals for bearings used at high speeds or above the speed (n) in **Figures 2** and **3** should be carefully considered and consulted with NSK. In these cases continuous relubrication techniques, such as circulating oil, may be more suitable than grease lubrication.

Vibration

Moderate, typical vibration should not have a negative effect on grease life. However, high vibration and shock levels, such as those in vibrating screen applications, can cause the grease to “slump” more quickly, resulting in a churning effect. In these cases the relubrication interval should be reduced. If the grease excessively softens, a grease with a better mechanical stability or grease with higher stiffness (ex. NLGI 3) should be used. Vibration can also damage bearings during static conditions or in applications where there is minimal relative motion between the rings. In those cases certain greases can be selected to minimize this damage condition known as false brinelling.

Contamination

In highly contaminated environments, grease aging is usually not the primary concern, as compared to the contaminants on the bearing surfaces. Therefore, more frequent relubrication can reduce the negative effects of foreign particles on the grease while reducing the damaging effects caused by the particles. Fluid contaminants (water, process fluids, etc.) also call for a reduced interval. In case of severe contamination, continuous relubrication should be considered. There are no standard calculations to determine lubrication interval because of contamination. Therefore, experience is the best indicator of how often to relubricate. It is generally accepted that the more frequent the relubrication the better. However, care should be taken to avoid over greasing a bearing in an attempt to force out contaminated grease. Using less grease on a more frequent basis rather than the full amount of grease each time is recommended. Excessive regreasing without the ability to purge will cause higher operating temperatures because of churning.

Outer Ring Rotation

In applications where the outer ring rotates or where there is a rotating load, the speed factor should be based on the bearing outside diameter D instead of the d_m . Also, the correct seals must be used to avoid grease loss due to purging (ex. use non-vented seals for ball bearings). For spherical roller thrust bearings with a rotating housing washer, oil lubrication is recommended.

Very Low Speeds

Bearings that operate at very low speeds (ex. Less than 20 rpm) and light loads require grease with low consistency. Bearings that operate at low speeds and heavy loads require a grease having a high viscosity, and if possible, good EP characteristics. Selecting the proper grease and grease fill is important in low speed applications. In some cases, 100% fills may be appropriate. In general, grease aging is not an issue for very low speed applications when bearing temperatures are less than 158°F (70°C). Therefore, relubrication is rarely required unless contamination occurs.

Vertical Shaft

An effective seal or retaining shield should be present below the bearing to prevent the grease from leaving the bearing cavity. Thicker consistency (ex. NLGI 3) greases may help reduce the amount of grease leakage. Consult with NSK for specific grease recommendations.

Very Heavy Loads

For bearings operating at a speed factor $n \times d_m > 20,000$ and with a load ratio $C/P < 4$, the relubrication interval should be reduced. Under these very heavy load conditions, continuous grease relubrication or oil bath lubrication is recommended. In applications where the speed factor n (inner ring rotational speed) $\times d_m$ (bearing mean diameter) is $< 20,000$ and the load ratio $C/P = 1-2$, see information under **Very Low Speeds**. For heavy loads and high speeds, circulating oil lubrication (possibly with cooling and filtration) is generally recommended.

Very Light Loads

The relubrication period may be extended if the loads are light ($C/P = 30$ to 50).

Large-Size Bearings

For proper relubrication intervals for large roller bearings ($d > 300$ mm) a more iterative, hands-on procedure is recommended. In these cases it is advisable to relubricate possibly more frequently than needed by adhering to recommended calculated regreasing quantities. However, before regreasing, the appearance of the used grease and the degree of contamination due to particles and water should be documented. Additionally, the bearing component (seals, cages, etc.) should be checked for wear, damage and general operation. When the condition of the grease and associated components are found to be acceptable, the relubrication interval can be set.

Very Short Intervals

If the determined value for the relubrication interval is too short for a particular application, it is recommended to:

- › Check the bearing operating temperature.
- › Check whether the grease is contaminated by solid particles or fluids.
- › Check the bearing application conditions such as load or misalignment.
- › Consider more suitable greases. NSK can supply recommendations.

GREASE REPLENISHMENT

Frequent grease replenishment is required when operating conditions are severe such as in high ambient temperatures or where contaminants can enter bearing housings. Routine regreasing schedules should be established. In cases where extremely severe conditions exist or the bearings are in a remote area, the bearing housing should be designed to make replenishment and replacement as simple as possible. Automatic grease systems are available and should be used.

For normal operating conditions, it may be necessary to regrease the bearing periodically to replace any grease which has leaked from the housing and to eliminate any deteriorated grease.

For assistance with calculating appropriate grease replenishment intervals, visit NSK's NAVI-FOCUS portal at www.nskamericas.com

OIL LUBRICATION

LUBRICATING OIL

The lubricating oils used for rolling bearings are usually highly refined mineral oil or synthetic oil that have a high oil film strength and superior oxidation and corrosion resistance. When selecting a lubricating oil, the viscosity at the operating conditions is important. If the viscosity is too low, a proper oil film is not formed and abnormal wear and seizure may occur. On the other hand, if the viscosity is too high, excessive viscous resistance may cause heating or large power loss. In general, low viscosity oils should be used at high speed; however, the viscosity should increase with increasing bearing load and size.

Table 4 gives generally recommended viscosities for bearings under normal operating conditions. For use when selecting the proper lubricating oil, **Figure 6** shows the relationship between oil temperature and viscosity, and examples of selection based on load and speed are shown in **Table 5** on page D13. **Figure 5** shows the relationship between oil temperature and viscosity in ISO, AGMA and SAE classifications.

Table 4 - Recommended Oil Viscosity by Bearing Type

BEARING TYPES	PROPER VISCOSITY AT THE OPERATING TEMPERATURE
Ball Bearings and Cylindrical Roller Bearings	Higher than 13 cSt
Tapered Roller Bearings and Spherical Roller Bearings	Higher than 20 cSt
Spherical Roller Thrust Bearings	Higher than 32 cSt

Fig. 5 - Comparative Viscosity Classifications

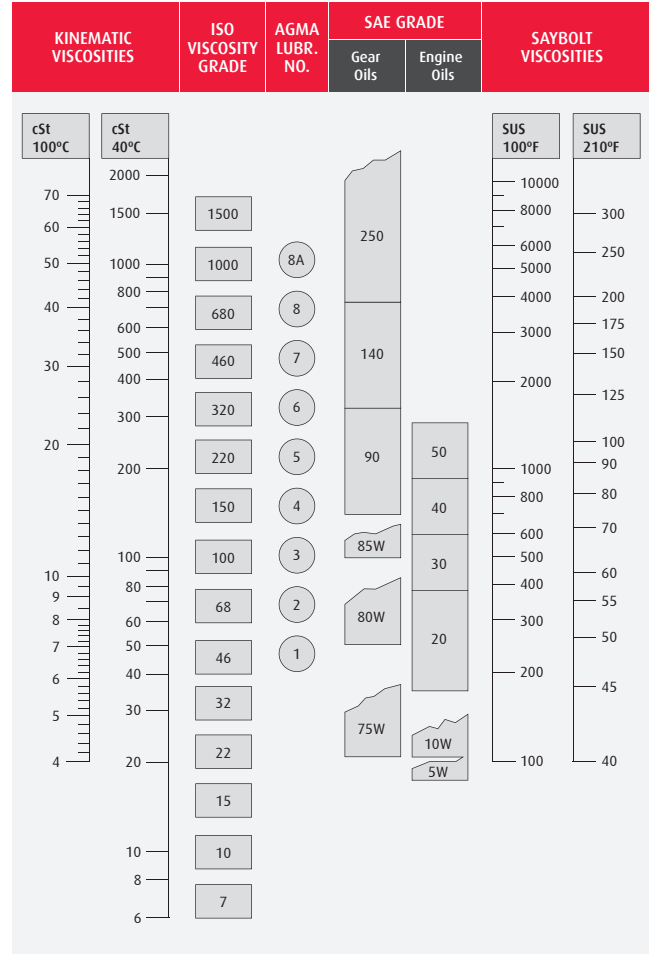

NOTES:

- 1) Viscosity can only be related horizontally.
- 2) Viscosities based on 95 VI single grade oils.
- 3) ISO and AGMA viscosities are specified at 40°C. SAE 5W, 10W, 75W, 80W and 85W viscosities are specified at low temperature. Equivalent viscosities at 100°F and 210°F are shown.
- 4) SAE 90-250 (gear oils) and SAE 20-50 (engine oils) are specified at 210° F / 99°C.

For assistance with calculating kinematic viscosity at operating temperatures, visit NSK's NAVI-FOCUS portal at www.nskamericas.com

Fig. 6 - Oil Temperature and Viscosity

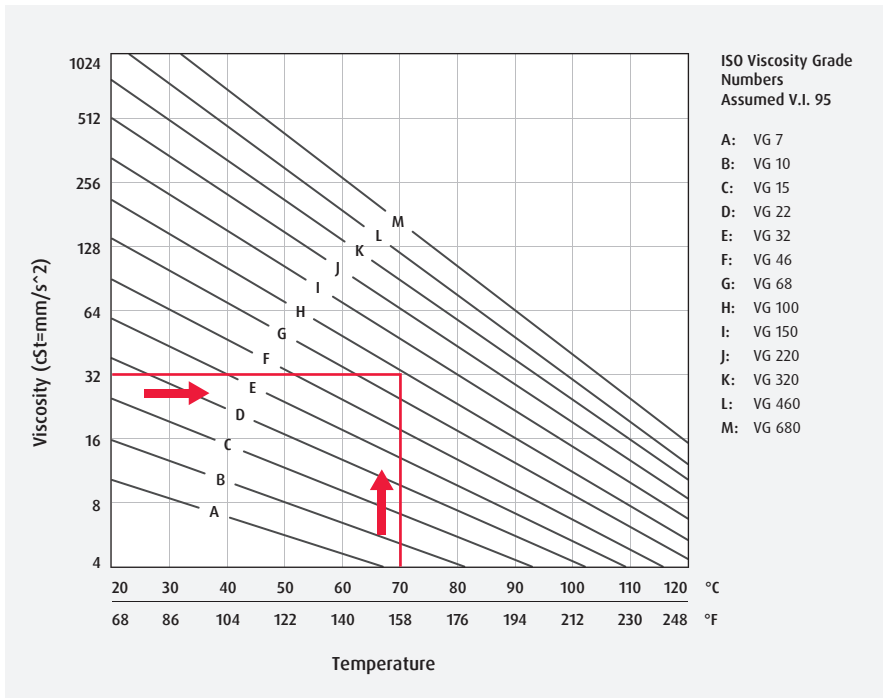

Figure 6 relates actual operating temperature to oil viscosity. To find an oil that satisfies the recommendation in **(Table 4)**, draw a line upward at the operating temperature until it intersects a line that has the required viscosity. Then read the ISO VG grade according to the letter code on the line.

Fig. 7 - Estimate of Required Viscosity at Operating Speed

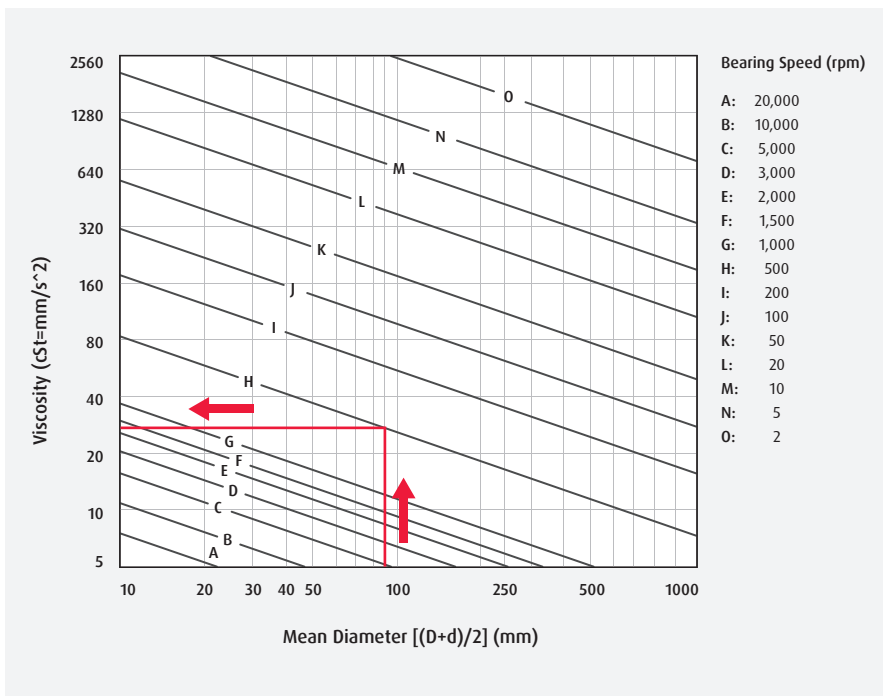

Figure 7 relates the bearing mean diameter ($(D + d) / 2$) to the estimated required viscosity at a given rotational speed. For example, a bearing with a pitch circle diameter of 90mm and rotating 500rpm, draw a line upward at 90 until it intersects line H (500rpm), then draw a line to the left to determine the viscosity of 30 cSt.

OIL LUBRICATION

Table 5 - Examples of Selecting Lubricating Oils

OPERATING TEMPERATURE	SPEED	LIGHT OR NORMAL LOAD	HEAVY OR SHOCK LOAD
-30 to 0°C -22 to 32°F	Less than limiting speed	ISO VG 15, 22, 32 (refrigerating machine oil)	--
0 to 50°C 32 to 122°F	< 50% of limiting speed	ISO VG 32, 46, 68 (bearing oil, turbine oil)	ISO VG 46, 68, 100 (bearing oil, turbine oil)
	50 to 100% of limiting speed	ISO VG 15, 22, 32 (bearing oil, turbine oil)	ISO VG 22, 32, 46 (bearing oil, turbine oil)
	> limiting speed	ISO VG 10, 15, 22 (bearing oil)	--
50 to 80°C 122 to 176°F	< 50% of limiting speed	ISO VG 100, 150, 220 (bearing oil)	ISO VG 150, 220, 320 (bearing oil)
	50 to 100% of limiting speed	ISO VG 46, 68, 100 (bearing oil, turbine oil)	ISO VG 68, 100, 150 (bearing oil, turbine oil)
	> limiting speed	ISO VG 32, 46, 68 (bearing oil, turbine oil)	--
80 to 100°C 176 to 212°F	< 50% of limiting speed	ISO VG 320, 460 (bearing oil)	ISO VG 460, 680 (bearing oil, gear oil)
	50 to 100% of limiting speed	ISO VG 150, 220 (bearing oil)	ISO VG 220, 320 (bearing oil)
	> limiting speed	ISO VG 68, 100 (bearing oil, turbine oil)	--

Note:

- 1) For the limiting speed, use the values listed in the bearing tables.
- 2) Refer to Refrigerating Machine Oils (JIS K 2211), Bearing Oils (JIS K 2239), Turbine Oils (JIS K 2213), and Gear Oils (JIS K 2219).
- 3) If the operating temperature is near the high end of the temperature range listed in the left column, select a high viscosity oil.
- 4) If the operating temperature is lower than -30°C or higher than 110°C, it is advisable to consult NSK.

METHODS OF OIL LUBRICATION

When the operating speed exceeds the grease limiting speed listed for the bearing, oil lubrication should be used. Oil features excellent flowability and heat dissipation capacity and is suitable for circulating and forced lubrication, two methods from which debris and abrasive particles are easily removed. It also has a positive effect on vibration and acoustic properties.

However, oil lubrication clearly adds complexity to the lubrication system and requires careful maintenance. Several methods are available and are described here. The best method to implement will depend on operating conditions.

Oil Bath Lubrication (Fig. 8) is a common method used where bearings are operating below the listed oil limiting speed. The static oil level should be set at the center of the lowest rolling element. An oil sight level gauge should be included in the system so that proper oil level can be quickly monitored.

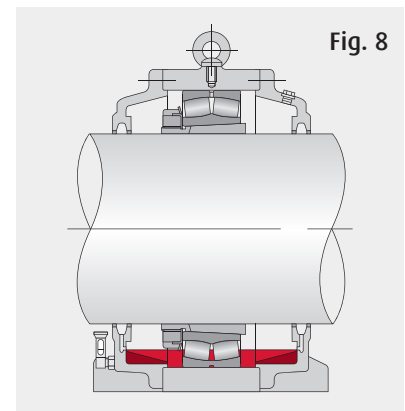

METHODS OF OIL LUBRICATION

Drip Feed Lubrication (Fig.9) is often used for small bearings operated at relatively high speeds. In the illustration, a visible oiler is used.

Splash Lubrication (Fig. 10) - In this lubricating method, oil is splashed onto the bearings by gears or by a simple rotating disc installed near bearings without submerging the bearings in oil. This method is commonly used in automobile transmissions, differentials and gear boxes. The illustration shows splash lubrication used on a reduction gear.

Circulating System Lubrication (Fig. 11) is commonly used for high speed operation requiring cooling for the bearing, and for bearings used at high temperatures. Typically, oil from the supply pipe circulates through the bearings and exits to an external reservoir. After cooling in the reservoir it returns to the bearing through a pump and filter. In a circulating system, the oil outlet should be larger in diameter than the supply pipe so that an excessive amount of oil will not remain in the housing.

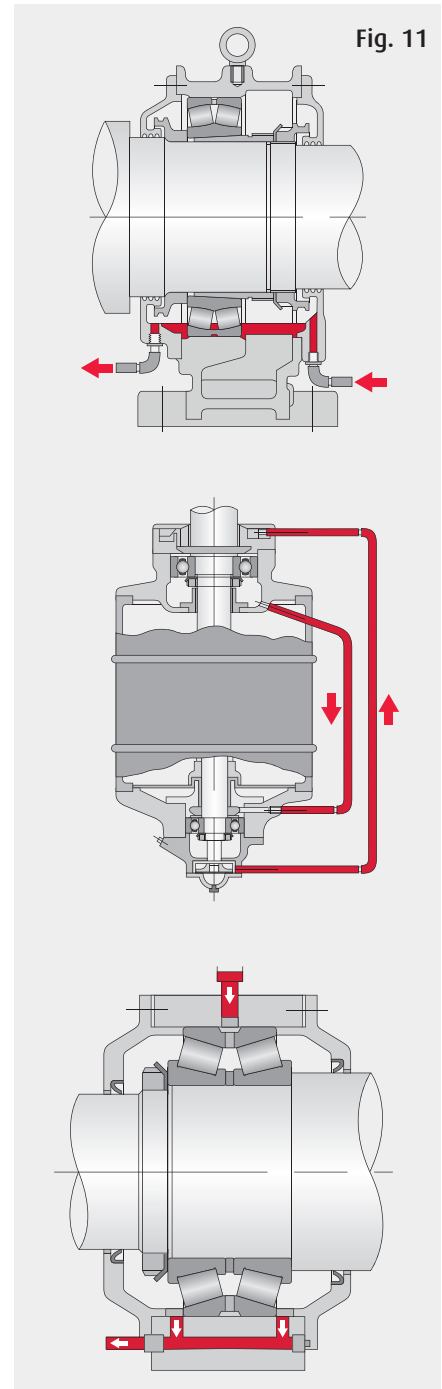
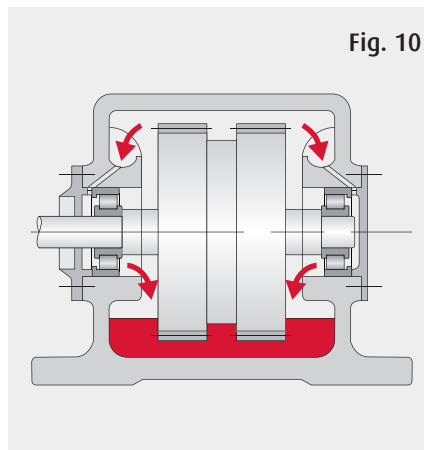
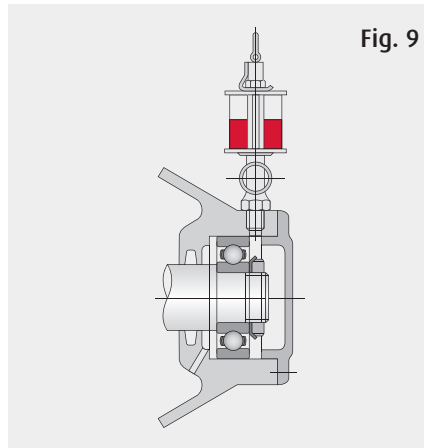

OIL LUBRICATION

METHODS OF OIL LUBRICATION

Jet Lubrication (Fig. 12) - is often used for ultra-high speed bearings, with a dmn value (dm : pitch diameter of rolling element set in mm, n : rotational speed in rpm) exceeding one million. Lubrication oil is sprayed under pressure from one or more nozzles directly into the bearing.

Figure 12 shows two examples of ordinary jet lubrication. The lubricating oil is sprayed on the inner ring and cage guide face. In the case of high speed operation, the air surrounding the bearing rotates with it causing the oil jet to be deflected. The jetting speed of the oil from the nozzle should be more than 20% of the circumferential speed of the inner ring outer surface.

More uniform cooling and a better temperature distribution are achieved using more nozzles for a given amount of oil. It is desirable for the oil to be forcibly discharged so the agitating resistance of the lubricant can be reduced and the oil can effectively carry away the heat.

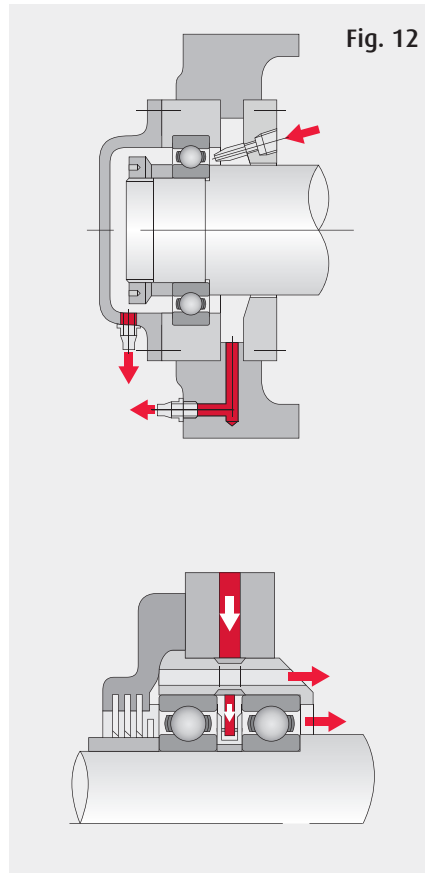

Fig. 12

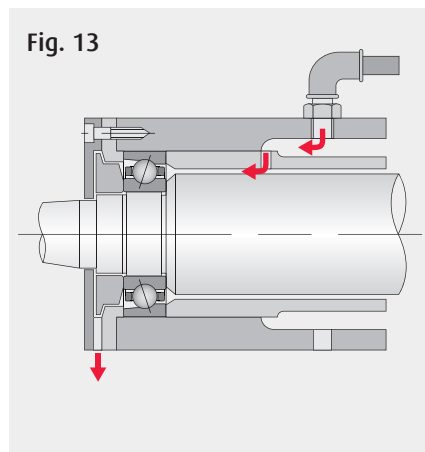

Fig. 13

Oil Mist Lubrication (Fig. 13) - also called oil fog lubrication, utilizes an oil mist sprayed into a bearing. This method has the following advantages:

- Because of the small quantity of oil required, the oil agitation resistance is small, and higher speeds are possible.
- Contamination of the vicinity around the bearing is slight because the oil leakage is small.
- It is relatively easy to continuously supply fresh oil; therefore, the bearing life is extended.

This lubricating method is used in bearings for the high speed spindles of machine tools, high speed pumps, roll necks of rolling mills, etc. For oil mist lubrication of large bearings, it is advisable to consult NSK.

Oil mist lubrication involves potential environmental hazards. Review OSHA requirements related to Oil Mist Systems.

Oil / Air Lubrication (Fig. 14) - Using this method, a very small amount of oil is discharged intermittently by a constant-quantity piston into a pipe carrying a constant flow of compressed air. The oil flows along the wall of the pipe and approaches a constant flow. The major advantages of oil/air lubrication are:

- a) Since the minimum necessary amount of oil is supplied, this method is suitable for high speeds because less heat is generated.
- b) Since the minimum necessary amount of oil is fed continuously, bearing temperature remains stable. Also, because of the small amount of oil, there is almost no atmospheric pollution.
- c) Since only fresh oil is fed to the bearings, oil deterioration need not be considered.
- d) Since compressed air is always fed to the bearings, the internal pressure is high, so dust, cutting fluid, etc. cannot enter.

For these reasons, this method is used in the main spindles of machine tools and other high-speed applications.

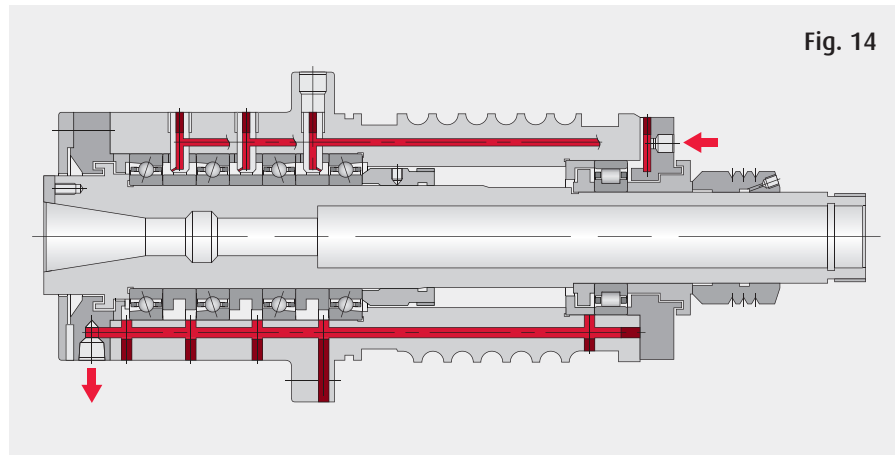

OIL REPLACEMENT INTERVALS

Oil replacement intervals depend on the operating conditions and oil quality. In those cases where the operating temperature is less than 50°C (122°F), and the environmental conditions are good with little dust, the oil should be replaced approximately once a year. However, in cases where the oil temperature is about 100°C (212°F), the oil must be changed at least once every three months. If moisture or foreign matter becomes mixed in the oil, then the oil replacement interval must be shortened.

MIXING OILS

Mixing different brands of oil must be prevented for the same reason given previously for grease.

MOLDED-OIL BEARINGS AND SOLID LUBE OPTIONS

NSK Molded-Oil bearings are uniquely designed to prevent the ingress of contamination that detrimentally impacts bearing performance, while providing a continuous and clean source of lubrication to the bearing. Oil-impregnated polyolefin resin serves as a barrier to water and dust, and slowly releases ample lubrication to the bearing with minimal risk of oil leakage.

FEATURES OF MOLDED-OIL BEARINGS

Excellent performance in water and dust contaminated environments

The bearings are designed to prevent liquids such as water (which can wash the lubricating oil out) and dust from getting inside the bearings. Sealed types can be used in environments exposed to water and dust.*

Environmentally friendly

Oil is released at the bearing surface only as needed, so little oil drips into the surrounding environment.

Low torque

The polymers in Molded-Oil do not interfere with the smooth rotation of rolling elements.

Optimal composition and molding methods enable high-speed operation of Molded-Oil Bearings

Optimization of composition and molding method of Molded-Oil improves strength and enables high-speed operation of Molded-Oil Bearings.

* Water and dust dramatically accelerate bearing damage. In order to realize stable operation, NSK recommends using seals to prevent water and dust ingress.



Table 6 - Molded-Oil Bearing Types and Availability

BEARING TYPES	MOLDED-OIL TYPES	CAGE TYPES	LIMITING SPEEDS (d_{mn})	SIZES (OUTSIDE DIAMETER, MM)
Spherical roller bearings	For general use	Machined brass (CA)	< 60,000	70 to 250
		Pressed steel (EA)	< 30,000	70 to 215
	For high-speed operation	Machined brass (CA)	60,000 to 100,000	70 to 215
Deep groove ball bearings	For general use	Pressed steel	< 150,000	19 to 250
	For high-speed operation	Pressed steel	150,000 to 200,000	19 to 215
Tapered roller bearings	For general use	Pressed steel	< 40,000	80 to 215

Note: $d_{mn} = [(\text{Bearing bore diameter, mm} + \text{Bearing outside diameter, mm}) \div 2] \times \text{inner ring rotational speed, min}^{-1}$

PRECAUTIONS FOR SELECTING

The following precautions should be considered to maintain the high performance of Molded-Oil Bearings:

- › For low-temperature applications to -10°F, Molded-Oil Bearings for general use are recommended.
- › For the condition of high ambient temperature up to 250°F, Molded-Oil Bearings for high-speed operation are recommended.
- › For proper operation, bearings must be under a radial load of at least 1% of the basic dynamic load rating to prevent skidding.
- › Since Molded-Oil Bearings are lubricated by capillary action, the bearings cannot be used under the condition where the bearings are exposed to water directly for an extended period of time (the oil could be washed away). If the application requires such exposure, consider using extra seals.

SOLID LUBE OPTIONS

Augmenting our “available from stock” Molded-Oil bearings, NSK also offers an expanded range of Solid Lube formulations for a variety of application challenges including:

- › extreme temperatures, with solutions for temperatures ranging from as low as -50°F to as high as 350°F
- › heavy loads with low speeds, with high viscosity oil to accommodate heavily loaded roller bearings
- › food grade solutions, including suitability for incidental food contact and food processing
- › high temperature wash down applications

These highly customized solutions can also be applied to a wider range of rolling bearing types including deep groove, angular contact and self-aligning ball bearings as well as spherical, cylindrical, tapered and thrust roller bearings.



SECTION E:

TROUBLESHOOTING / BEARING DAMAGE

BEARING HANDLING AND MAINTENANCE	E3
Mounting	E3
Check the Operation	E3
Maintenance	E3
Inspection Under Operating Conditions	E4
Inspection of the Bearing	E4
BEARING PERFORMANCE FACTORS	E5
Noise	E5
Vibration	E5
Temperature	E5
Effects of Proper Lubrication	E5
BEARING INSPECTION	E6
Evaluating the Bearing	E7
Running Traces and Applied Loads	E8
Ball Bearings	E8
Roller Bearings	E9
BEARING DAMAGE AND COUNTERMEASURES	E10
Flaking (or Spalling)	E11
Scoring	E13
Peeling	E15
Fracture	E16
Smearing	E17
Cracks	E19
Cage Damage	E21
Denting	E23
Pitting	E24
Wear	E25
Fretting	E26
False Brinelling	E27
Creep	E28
Seizure	E29
Electrical Erosion	E31
Rust and Corrosion	E33
Mounting Flaws	E34
Discoloration	E35
BEARING DAMAGE DIAGNOSTIC CHART	E36

BEARING HANDLING & MAINTENANCE

When a rolling bearing is damaged during machine operation, the entire machine or equipment may seize or malfunction. Since bearings that fail prematurely or unexpectedly cause unplanned downtime, it is important to be able to identify potential failures in order to avoid future risk.

Generally, bearing and/or application inspection can identify the cause of the problem. Often the cause is attributable to poor lubrication, improper handling, selecting the wrong bearing, or improper shaft or housing fits. Usually the cause can be determined by considering operation of the bearing before the failure, investigating the lubrication conditions and the mounting condition, and carefully observing the damaged bearing itself.

INSTALLATION PRACTICES

Careful consideration of bearing installation practices is important as it influences the bearing's running accuracy, life and performance. It is recommended that the mounting method includes the following considerations:

- › **Clean the bearing and surrounding components**
- › **Check the dimensions and finish of related parts**
- › **Carefully follow mounting procedure**
- › **Verify the bearing is mounted correctly in the application**
- › **Ensure the bearing is supplied with sufficient and correct lubrication**

Since most bearings rotate with the shaft, the bearing mounting method is generally an interference (tight) fit for the inner ring and shaft while giving a clearance (loose) fit for the outer ring and housing.

CHECK THE OPERATION

After mounting the bearing, it is important to carry out an operating test to confirm that the bearing is mounted properly. **Table 1** indicates operating test methods. If irregularities are detected, immediately suspend the test and consult **Table 2** on **page E6** which lists appropriate countermeasures to specific bearing problems.

MAINTENANCE

It is necessary to periodically inspect and maintain the bearing and its operating conditions in order to maximize the bearing life. In general, the following method is adopted.



BEARING INSPECTION UNDER OPERATING CONDITIONS

To determine the appropriate bearing inspection interval and replenishment intervals for lubricant, investigate the lubricant properties and consider factors such as operating temperature, vibration, and bearing noise.

Be sure to inspect the bearing thoroughly during machine maintenance. If possible, check the raceway condition. Determine if damage exists. Confirm if the bearing can be reused or should be replaced.

Table 1 - Methods To Check Operation

MACHINE SIZE	OPERATING PROCEDURE	LIGHT OR NORMAL LOAD
Small machine	Manual operation. With the machine power off, rotate the bearing by hand. If no problems are detected, then proceed to operate the machine.	<ul style="list-style-type: none"> › Stick-slip (Debris, cracks, dents) › Uneven rotating torque (Faulty mounting) › Excessive torque (Error in mounting or insufficient radial internal clearance)
	Power operation. Initially start at a low speed and without a load. Gradually increase the speed and load until normal operating conditions are achieved.	Check for irregular noise. Check for bearing temperature rise, lubricant leakage, and/or discoloration.
Large machine	Idle operation. Turn ON power and allow machine to rotate slowly. Turn OFF the power and allow the bearing to coast to a stop. If no irregularities are detected by the test, then proceed to the loaded rotation testing.	Vibration, noise, etc.
	Power operation. Follow the same power operation testing as used for small machine testing.	Follow the same checkpoints as the small machine test.

BEARING PERFORMANCE FACTORS

Key bearing performance factors during operation are bearing noise, vibration, temperature, and lubricant condition. Please refer to Table 2 if any operation irregularities are detected.

BEARING NOISE

During operation, sound detection instruments (stethoscope, NSK Bearing Monitor, etc.) can be used to investigate the volume and characteristics of the bearing rotation noise. It is possible to distinguish bearing damage such as small flaking by means of its unusual yet characteristic noise.

BEARING VIBRATION

Bearing irregularities can be analyzed by measuring the vibrations of an operating machine. A frequency spectrum analyzer is used to measure the magnitude of vibration and the distribution of the frequencies. Analysis results can determine if the bearing is the source of the vibration, and can often determine defects in surrounding components. The measured data varies depending on the operating conditions of the bearing and the location of the vibration pick-up. Therefore, the method requires the determination of evaluation standards for each measured machine. It is useful to be able to detect irregularities from the bearing vibration pattern during operation.

BEARING TEMPERATURE

Generally, the bearing temperature can be estimated from the temperature of the housing outside surface, but a preferable way is to obtain direct measurements from the outer ring by a probe going through an oil hole. Usually, the bearing temperature gradually increases after the start of operation until reaching a steady state condition about 1 or 2 hours later. The bearing steady state temperature depends on load, rotational speed and heat transfer properties of the machine. Insufficient lubrication or improper mounting might cause the bearing temperature to rise rapidly. In such a case, suspend the machine operation and adopt an appropriate countermeasure.

EFFECTS OF PROPER LUBRICATION

The two main purposes of lubrication are to minimize friction and reduce wear inside bearings that might otherwise fail prematurely. Lubrication provides the following advantages:

› Minimize Friction and Wear

Direct metallic contact between the bearing rings, rolling elements and cage, which are the basic components of a bearing, is prevented by an oil film which reduces the friction and wear in the contact areas.

› Extension of Fatigue Life

Properly selected lubrication viscosity and film thickness is essential to optimizing bearing fatigue life. A viscosity selection that is too light or excessively heavy can create operating conditions detrimental to bearing life.

› Dissipation of Frictional Heat and Cooling

Circulating lubrication may be used to carry away either frictional heat or heat transferred from the outside to prevent the bearing from overheating and the oil from deteriorating.

› Sealing and Rust Prevention

Adequate lubrication also helps to prevent foreign material from entering the bearings and guards against corrosion or rusting.

Table 2 - Causes And Countermeasures For Operating Irregularities

IRREGULARITIES		POSSIBLE CAUSES	COUNTERMEASURES
Noise	Loud Metallic Sound	Abnormal load	Improve the fit, internal clearance, preload, position of housing shoulder, etc.
		Incorrect mounting	Improve the machining accuracy and alignment of shaft and housing, accuracy of mounting method.
		Insufficient or improper lubricant	Replenish the lubricant or select another lubricant.
		Contact of rotating parts	Modify the labyrinth seal, etc.
	Loud Regular Sound	Flaws, corrosion, or scratches on raceways	Replace or clean the bearing, improve the seals, and use clean lubricant.
		Brinelling	Replace the bearing and use care when handling bearings.
		Flaking on raceway	Replace the bearing.
	Irregular Sound	Excessive clearance	Improve the fit, clearance and preload.
		Penetration of foreign particles	Replace or clean the bearing, improve the seals, and use clean lubricant.
		Flaws or flaking on balls	Replace the bearing.
Abnormal Temperature Rise	Excessive amount of lubricant	Reduce amount of lubricant, select stiffer grease.	
	Insufficient or improper lubricant	Replenish lubricant or select a better one.	
	Abnormal load	Improve the fit, internal clearance, preload, position of housing shoulder.	
	Incorrect mounting	Improve the machining accuracy and alignment of shaft and housing, accuracy of mounting, or mounting method.	
	Creep on fitted surface, excessive seal friction	Correct the seals, replace the bearing, correct the fitting or mounting.	
Vibration (Axial runout)	Brinelling	Replace the bearing and use care when handling bearings.	
	Flaking	Replace the bearing.	
	Incorrect mounting	Correct the squareness between the shaft and housing shoulder or side of spacer.	
	Penetration of foreign particles	Replace or clean the bearing, improve the seals.	
Leakage or Discoloration of Lubricant	Too much lubricant; penetration by foreign matter or abrasion chips	Reduce the amount of lubricant, select a stiffer grease. Replace the bearing or lubricant. Clean the housing and adjacent parts.	

BEARING INSPECTION

When inspecting a bearing during periodic equipment inspections, operating inspections, or replacement of adjacent parts, determine the condition of the bearing and if its continued service is advisable.

A record should be kept of the inspection and external appearance of dismantled bearings. Take a grease or oil sample. Observe the lubricant appearance and volume, then the bearing can be cleaned and inspected. Once unmounted and cleaned, visual observations can be made of the rollers, rings, cage, and fitting surfaces for obvious signs of damage, elevated temperatures or other forms of distress. Refer to **Running Traces and Applied Loads (Page E8)** regarding the observation of running traces on the raceway surface.

When evaluating whether a bearing can be reused or not, the following points need to be considered: degree of bearing damage, machine performance, critical nature of the application, operating conditions, inspection interval. If the inspection reveals bearing damage or abnormalities, then try to confirm the cause and determine a countermeasure by referring to **Bearing Damage and Countermeasures (Page 10)** and then carry out the countermeasure.

If the inspection reveals any of the following evidence, the bearing should be replaced:

- › Excessive load
- › Misalignment
- › Contamination (foreign debris)
- › Corrosion (water penetration)
- › Corrosion induced damage (pits, debris denting, spalling)
- › Incorrect shaft and/or housing fit
- › Excessive temperatures



RUNNING TRACES AND APPLIED LOADS

As the bearing rotates, the raceways of the inner ring and the outer ring make contact with the rolling elements. This results in a wear path on both the rolling elements and raceways. It is normal for the running trace to be marked on the raceway. The size and the extent and shape of this running trace provides a useful indication of loading conditions. It is possible to determine from careful observation of the running traces whether the bearing is carrying a radial load, a large axial load, or a moment load, or if there are extreme rigidity variations of the housing. Unexpected loads applied to the bearing, excessive mounting error, or other operating issues can be determined, providing a clue to potential causes for bearing failure.

Representative running traces of deep groove ball bearings are shown in **Figure 1**. The **Figures 1.1 to 1.4**, show general running traces under radial load or axial load. The running traces vary according to whether the load is fixed to the inner ring or the outer ring, and according to load conditions.

Figure 1.5 shows running traces with a shaft inclined due to misalignment; **Figure 1.6** is a running trace under a moment load; **Figure 1.7** is a running trace in a housing which is elliptically shaped and has poor inner diameter accuracy; and **Figure 1.8** is a running trace in a bearing with insufficient internal clearance. Running traces in **Figures 1.5 to 1.8** often indicate specific causes of bearing failure and must be carefully observed.

Fig. 1 - Typical Running Traces Of Deep Groove Ball Bearings

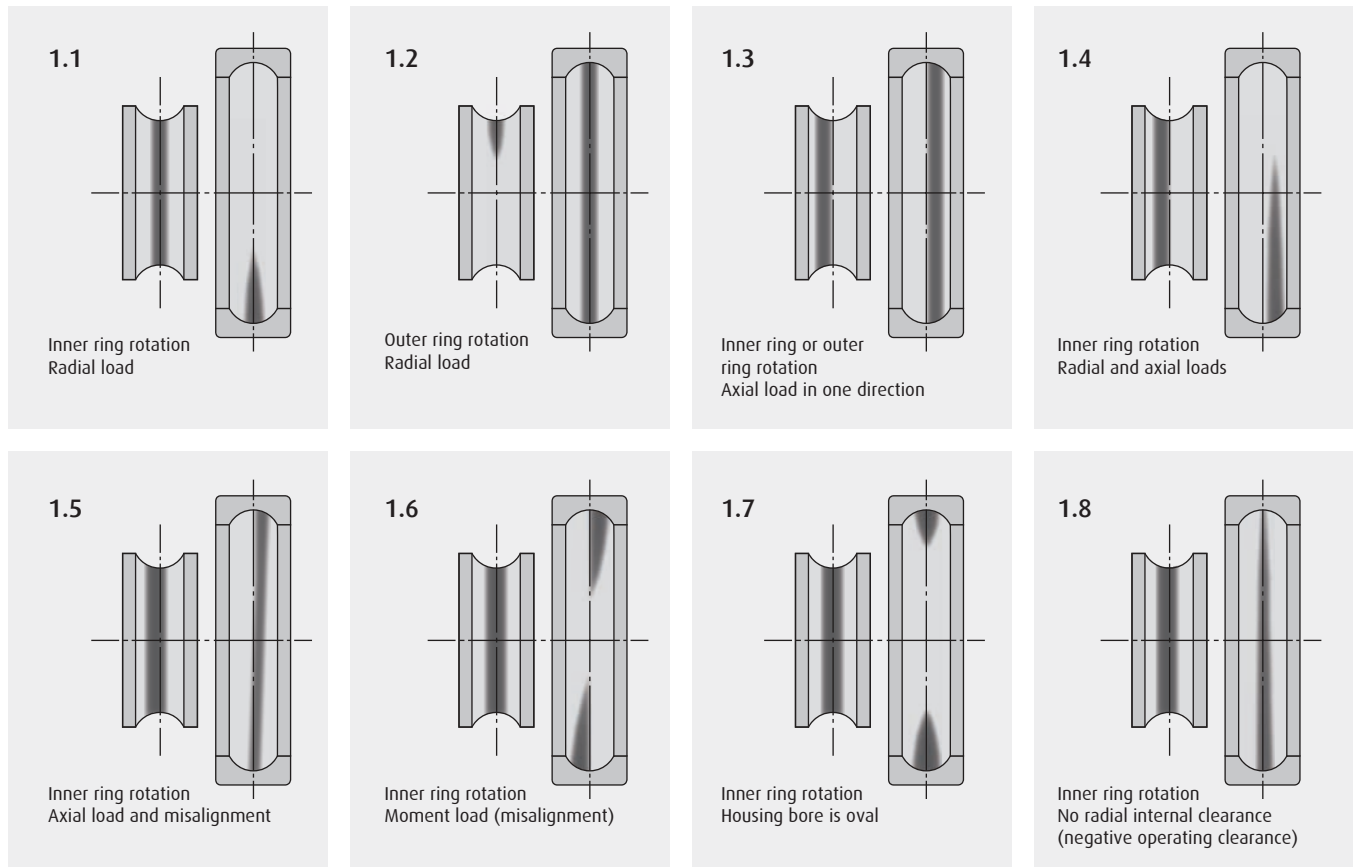

BEARING INSPECTION

Fig. 2 - Typical Running Traces Of Roller Bearings

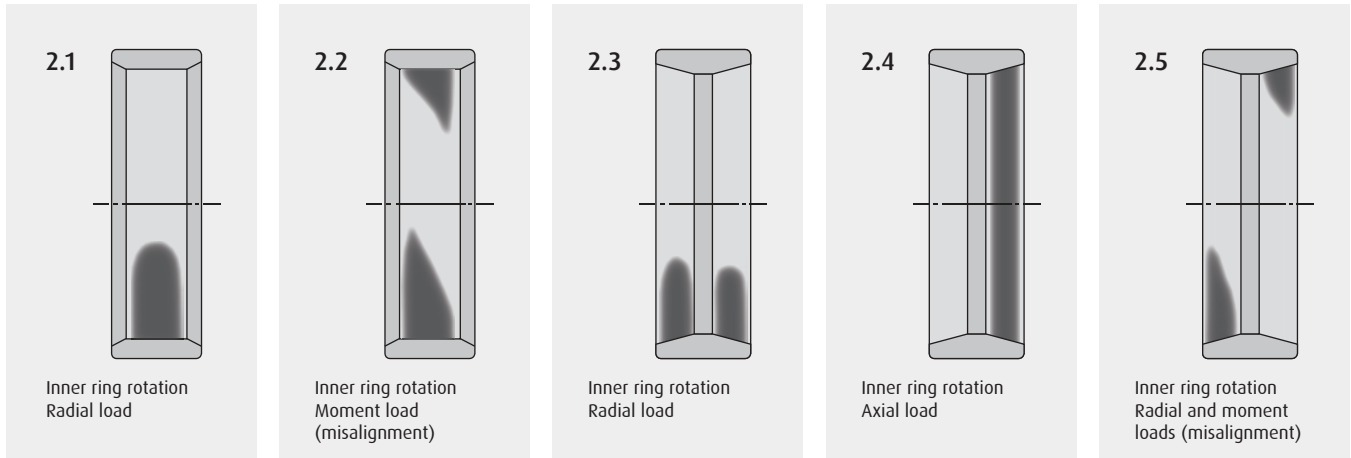

Figure 2 shows the running traces generated in roller bearings under various load conditions.

Figure 2.1 shows the outer ring running trace when a radial load is properly applied to a cylindrical roller bearing which has a load on a rotating inner ring.

Figure 2.2 shows the running trace in the case of shaft bending or relative inclination between the inner and outer rings. This misalignment leads to the generation of slightly shaded (dull) bands in the width direction. Traces are diagonal at the beginning and end of the loading zone.

For double-row tapered roller bearings where a single load is applied to the rotating inner ring. **Figure 2.3** shows the running trace on the outer ring under axial load while **Figure 2.4** shows the running trace on the outer ring under axial load.

When misalignment exists between the inner and the outer rings, then the application of a radial load causes running traces to appear on the outer ring as shown in **Figure 2.5**.

In general, if rolling bearings are used correctly, they will survive to their predicted fatigue life. Bearings, however, often fail prematurely due to avoidable mistakes. In contrast to fatigue life, a premature failure is commonly caused by improper mounting, mishandling, poor lubrication, contamination or abnormal heat generation.

If all conditions are known for the times both before and after the failure, including the application, the operating conditions, and environment, then a countermeasure can be determined by studying the nature of the failure and its probable causes. A successful countermeasure will prevent reoccurrence of a similar failure.

The following pages give examples of bearing damage and countermeasures. Please consult these sections when trying to determine the cause of bearing damage. The bearing diagnostic chart on page **E36** be useful as a quick reference guide.

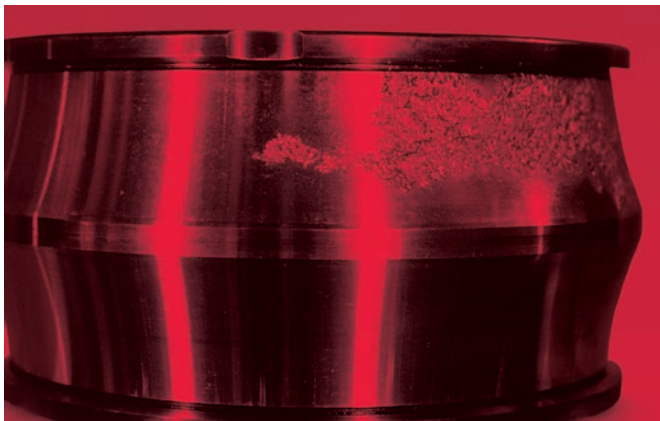

BEARING DAMAGE AND COUNTERMEASURES

FLAKING (OR SPALLING)

DAMAGE CONDITION

Flaking (sometimes referred to as spalling) occurs when small pieces of bearing material are split off from the smooth surface of the raceway or rolling elements due to rolling fatigue, thereby creating regions having a rough and coarse texture.

POSSIBLE CAUSE

- › Excessive load
- › Poor mounting (misalignment)
- › Moment load
- › Entry of foreign debris, water penetration
- › Poor lubrication, Improper lubricant
- › Unsuitable bearing clearance
- › Improper precision for shaft or housing, unevenness in housing rigidity, large shaft bending
- › Progression from rust, corrosion pits, smearing, dents (Brinelling)

COUNTERMEASURE

- › Reconfirm the bearing application & check the load conditions
- › Improve the mounting method
- › Improve the sealing mechanism, prevent rusting during non-running
- › Use a lubricant with a proper viscosity, improve the lubrication method
- › Check the precision of shaft and housing
- › Check the bearing internal clearance



Part:
Inner ring of an angular contact ball bearing

Observation:
Flaking occurs diagonally along raceway

Cause:
Poor alignment between shaft and housing during mounting

1.1



Part:
Inner ring of deep groove ball bearing

Observation:
Flaking of raceway at ball pitch

Cause:
Dents due to shock load during mounting

1.2



Part:
Inner ring of an angular contact ball bearing

Observation:
Flaking of raceway at ball pitch

Cause:
Dents due to shock load while stationary

1.3



Part:
Outer ring of Photo 1.3

Observation:
Flaking of raceway surface at ball pitch

Cause:
Dents due to shock load while stationary

1.4



Part:
Balls of Photo 1.3

Observation:
Flaking of ball surface

Cause:
Dents due to shock load while stationary

1.5



Part:
Inner ring of a spherical roller bearing

Observation:
Flaking of only one raceway over its entire circumference

Cause:
Excessive axial load

1.6



Part:
Outer ring of Photo 1.6

Observation:
Flaking of only one raceway over its entire circumference

Cause:
Excessive axial load

1.7



Part:
Inner ring of a spherical roller bearing

Observation:
Flaking of only one row of raceway

Cause:
Poor lubrication

1.8



Part:
Rollers of a cylindrical roller bearing

Observation:
Premature flaking occurs axially on the rolling surfaces

Cause:
Scratches caused during improper mounting

1.9

SCORING

DAMAGE CONDITION

Scoring is surface damage due to accumulated small seizures caused by sliding under improper lubrication or under severe operating conditions. Linear damage appears circumferentially on the raceway surface and rolling surface. Cycloidal shaped damage on the roller end. Scoring on rib surface contacting roller end.

POSSIBLE CAUSE

- › Excessive load, excessive preload
- › Poor lubrication
- › Particles are caught between surfaces with relative motion
- › Inclination of inner and outer rings
- › Shaft bending
- › Poor precision of the shaft and housing

COUNTERMEASURE

- › Check the size of the load
- › Adjust the preload
- › Improve the lubricant and the lubrication method
- › Check the precision of the shaft and housing

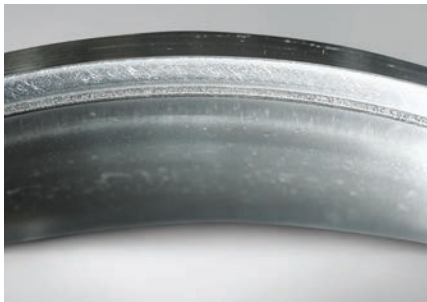

Part:
Inner ring of a spherical roller bearing

Observation:
Scoring on large rib face of inner ring

Cause:
Roller slipping due to sudden acceleration and deceleration

2.1



Part:
Convex rollers of Photo 2.1

Observation:
Scoring on roller end face

Cause:
Roller slipping due to sudden acceleration and deceleration

2.2



Part:
Inner ring of a tapered roller thrust bearing

Observation:
Scoring on the face of inner ring rib

Cause:
Worn particles become mixed with lubricant, and breakdown of oil film occurs due to excessive load

2.3



Part:
Rollers of a double-row cylindrical roller bearing

Observation:
Scoring on the roller end face

Cause:
Poor lubrication and excessive axial load

2.4



Part:
Inner ring of a spherical thrust roller bearing

Observation:
Scoring on the rib face of inner ring

Cause:
Debris, which is caught in surface, and excessive axial loading

2.5



Part:
Convex rollers of Photo 2.5

Observation:
Scoring on the roller end face

Cause:
Debris, which is caught in surface, and excessive axial loading

2.6



Part:
Cage of a deep groove ball bearing

Observation:
Scoring on the pressed-steel cage pockets

Cause:
Entry of debris

2.7

BEARING DAMAGE AND COUNTERMEASURES

PEELING

DAMAGE CONDITION

Dull or cloudy spots appear on surface along with light wear. From such dull spots, tiny cracks are generated inward to a depth of 5 to 10 µm. Small particles fall off and minor flaking occurs widely.

POSSIBLE CAUSE

- › Unsuitable lubricant
- › Entry of debris into lubricant
- › Rough surface due to poor lubrication
- › Surface roughness of mating rolling part

COUNTERMEASURE

- › Select a proper lubricant
- › Improve the sealing mechanism
- › Improve the surface finish of the rolling mating parts

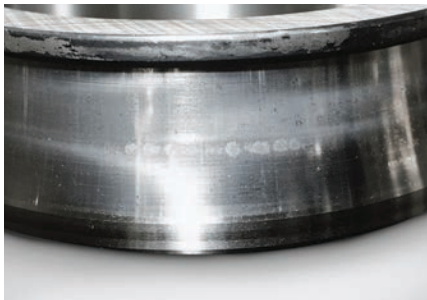

Part:
Inner ring of a spherical roller bearing

Observation:
Round shaped peeling pattern occurs on the center of the raceway surface

Cause:
Poor lubrication

3.1



Part:
Convex rollers of Photo 3.1

Observation:
Round shaped peeling pattern occurs on the center of the rolling surfaces

Cause:
Poor lubrication

3.2



Part:
Outer ring of a spherical roller bearing

Observation:
Peeling occurs near the shoulder of the raceway over the entire circumference

Cause:
Poor lubrication

3.3

DAMAGE CONDITION

Fracture refers to small pieces which were broken off due to excessive load or shock load acting locally on a part of the roller corner or rib of a raceway ring.

POSSIBLE CAUSE

- › Impact during mounting
- › Excessive load
- › Poor handling such as dropping

COUNTERMEASURE

- › Improve the mounting method (Shrink fit, use of proper tools)
- › Reconsider the loading conditions
- › Provide enough back-up and support for the bearing rib



Part:
Inner ring of a double-row cylindrical roller bearing

Observation:
Chipping occurs at the center rib

Cause:
Excessive load during mounting

4.1

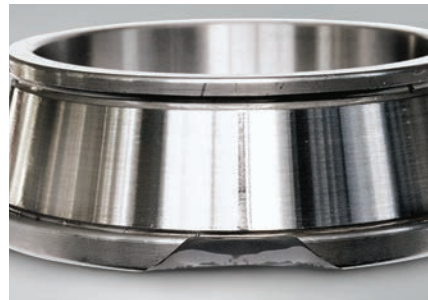

Part:
Inner ring of a tapered roller bearing

Observation:
Fracture occurs at the cone back face rib surface

Cause:
Large shock during mounting

4.2



Part:
Inner ring of a spherical thrust roller bearing

Observation:
Fracture occurs at the large rib

Cause:
Repeated load

4.3

BEARING DAMAGE AND COUNTERMEASURES

SMEARING

DAMAGE CONDITION

Smearing is surface damage which occurs from a collection of small seizures between bearing components caused by oil film rupture and/or sliding. Surface roughening occurs along with melting.

POSSIBLE CAUSE

- › High speed and light load
- › Sudden acceleration/deceleration
- › Improper lubricant
- › Entry of water

COUNTERMEASURE

- › Improve the preload
- › Improve the bearing clearance
- › Use a lubricant with good oil film formation ability
- › Improve the lubrication method
- › Improve the sealing mechanism



Part:
Inner ring of a cylindrical roller bearing

Observation:
Smearing occurs circumferentially on raceway surface

Cause:
Roller slipping due to excessive grease filling

5.1

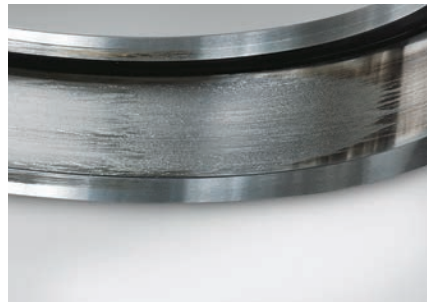

Part:
Outer ring of Photo 5.1

Observation:
Smearing occurs circumferentially on raceway surface

Cause:
Roller slipping due to excessive grease filling

5.2

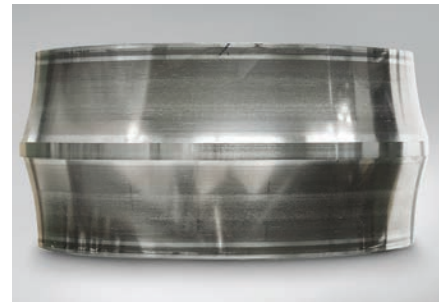

Part:
Inner ring of a spherical roller bearing

Observation:
Smearing occurs circumferentially on raceway surface

Cause:
Poor lubrication

5.3



Part:
Outer ring of Photo 5.3

Observation:
Smearing occurs circumferentially on raceway surface

Cause:
Poor lubrication

5.4

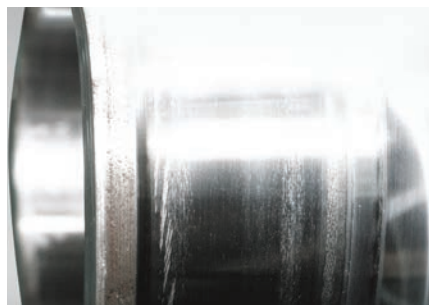

Part:
Inner ring of a spherical roller bearing

Observation:
Partial smearing occurs circumferentially on raceway surface

Cause:
Poor lubrication

5.5



Part:
Outer ring of Photo 5.5

Observation:
Partial smearing occurs circumferentially on raceway surface

Cause:
Poor lubrication

5.6



Part:
Convex rollers of Photo 5.5

Observation:
Smearing occurs at the center of the rolling surface

Cause:
Poor lubrication

5.7

BEARING DAMAGE AND COUNTERMEASURES

CRACKS

DAMAGE CONDITION

Cracks in the raceway ring and rolling elements. Continued use under this condition leads to larger cracks or fractures.

POSSIBLE CAUSE

- › Excessive interference
- › Excessive load, shock load
- › Progression of flaking
- › Heat generation and fretting caused by contact between mounting parts and raceway ring
- › Heat generation due to creep
- › Poor taper angle of tapered shaft
- › Poor cylindricality of shaft
- › Interference with bearing chamfer due to a large shaft

COUNTERMEASURE

- › Correct the interference
- › Check the load conditions
- › Improve the mounting method
- › Use an appropriate shaft shape

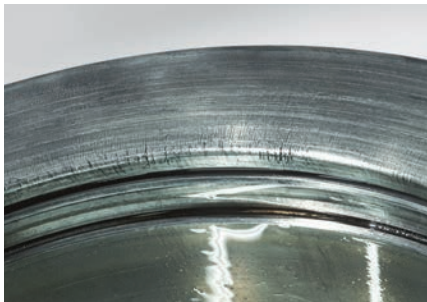

Part:

Outer ring of a double-row cylindrical roller bearing

Observation:

Thermal cracks occur on the outer ring side face

Cause:

Abnormal heat generation due to contact sliding between mating part and face of outer ring

6.1



Part:

Roller of a tapered roller thrust bearing

Observation:

Thermal cracks occur at large end face of roller

Cause:

Heat generation due to sliding with the inner ring rib under poor lubrication

6.2



Part:

Outer ring of a double-row cylindrical roller bearing

Observation:

Cracks propagated outward in the axial and circumferential directions from the flaking origin on the raceway surface

Cause:

Flaking from a flaw due to shock

6.3



Part:
Outer ring of a double-row cylindrical roller bearing used for outer ring rolling (outer ring rotation)

Observation:
Cracks occur on outside surface

Cause:
Flat wear and heat generation due to non-rotation of the outer ring

6.4



Part:
Raceway surface of outer ring in Photo 6.4

Observation:
Outside surface crack developing on the raceway

6.5



Part:
Inner ring of a spherical roller bearing

Observation:
Axial cracks occur on raceway surface

Cause:
Large fitting stress due to temperature difference between shaft and inner ring

6.6



Part:
Cross section of a fractured inner ring in Photo 6.6

Observation:
Origin is directly beneath the raceway surface

6.7



Part:
Roller of a spherical roller bearing

Observation:
Axial cracks occur on rolling surface

6.8

CAGE DAMAGE

DAMAGE CONDITION

Cage damage includes cage deformation, fracture and wear. Fracture of cage pillar. Deformation of side face. Wear of pocket surface. Wear of guide surface.

POSSIBLE CAUSE

- › Poor mounting (bearing misalignment)
- › Poor handling
- › Large moment load
- › Shock and large vibration
- › Excessive rotation speed, sudden acceleration and deceleration
- › Poor lubrication
- › Temperature rise

COUNTERMEASURE

- › Check the mounting method
- › Check the temperature, rotation, and load conditions
- › Reduce the vibration
- › Select a different cage type
- › Select a different lubrication method and lubricant



Part:

Cage of a deep groove ball bearing

Observation:

Fracture of pressed-steel cage-pocket

7.1



Part:

Cage of an angular contact ball bearing

Observation:

Pocket pillar fractures from a cast iron machined cage

Cause:

Abnormal load action on cage due to misaligned mounting between inner and outer rings

7.2

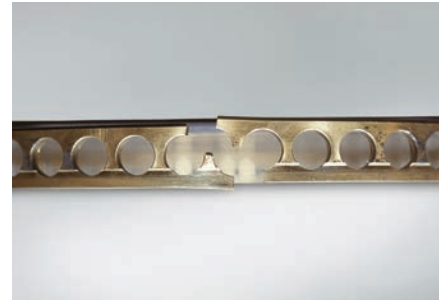

Part:

Cage of an angular contact ball bearing

Observation:

Fracture of machined high-tension brass cage

7.3



Part:
Cage of a tapered roller bearing

Observation:
Pillar fractures of pressed-steel cage

7.4

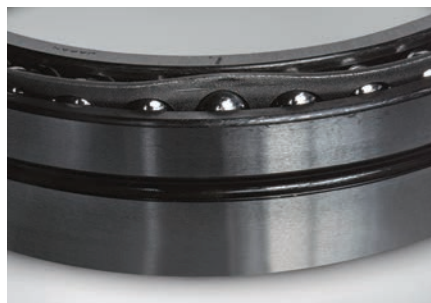

Part:
Cage of an angular contact ball bearing

Observation:
Pressed-steel cage deformation

Cause:
Shock load due to poor handling

7.5



Part:
Cage of a cylindrical roller bearing

Observation:
Deformation of the side face of a machined high-tension brass cage

Cause:
Large shock during mounting

7.6



Part:
Cage of a cylindrical roller bearing

Observation:
Deformation and wear of a machined high-tension brass cage

7.7



Part:
Cage of an angular contact ball bearing

Observation:
Stepped wear on the outside surface and pocket surface of a machined high-tension brass cage

7.8

BEARING DAMAGE AND COUNTERMEASURES

DENTING

DAMAGE CONDITION

When debris such as small metallic particles are caught in the rolling contact zone, denting occurs on the raceway surface or rolling element surface. Denting can occur at the rolling element pitch interval if there is a shock during the mounting (brinell dents).

POSSIBLE CAUSE

- › Debris such as metallic particles is caught between surfaces with relative motion
- › Excessive load
- › Shock during transport or mounting

COUNTERMEASURE

- › Wash the housing
- › Improve the sealing mechanism
- › Filter the lubrication oil
- › Improve the mounting and handling methods

**Part:**

Outer ring of a double-row tapered roller bearing

Observation:

Indentations on raceway surface

Cause:

Debris caught between rolling element and raceway

8.1

**Part:**

Inner ring of a tapered roller bearing

Observation:

Small and large indentations occur over entire raceway surface

Cause:

Debris caught between rolling element and raceway

8.2

**Part:**

Tapered rollers of Photo 8.2

Observation:

Small and large indentations occur over the rolling surface

Cause:

Debris caught between rolling element and raceway

8.3

DAMAGE CONDITION

The pitted surface has a dull luster which appears on the rolling element surface or raceway surface.

POSSIBLE CAUSE

- › Debris becomes caught in the lubricant
- › Exposure to moisture in the atmosphere
- › Poor lubrication

COUNTERMEASURE

- › Improve the sealing mechanism
- › Filter the lubrication oil thoroughly
- › Use a proper lubricant

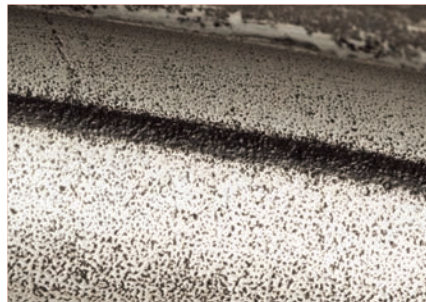

Part:
Outer ring of a slewing bearing

Observation:
Pitting occurs on the raceway surface

Cause:
Rust at bottoms of indentations

9.1

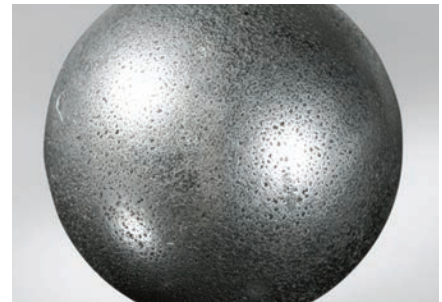

Part:
Ball of Photo 9.1

Observation:
Pitting occurs on the rolling element surface

9.2

WEAR

DAMAGE CONDITION

Wear is surface deterioration due to sliding friction at the surface of the raceway, rolling elements, roller end faces, rib face, and cage pockets.

POSSIBLE CAUSE

- › Entry of debris
- › Progression from rust and electrical erosion
- › Poor lubrication
- › Sliding due to irregular motion of rolling elements

COUNTERMEASURE

- › Improve the sealing mechanism
- › Clean the housing
- › Filter the lubrication oil thoroughly
- › Check the lubricant and lubrication method
- › Prevent misalignment



Part:
Outer ring of a spherical roller bearing

Observation:
Wear having a wavy or concave and convex texture on loaded side of raceway surface

Cause:
Entry of debris under repeated vibration while stationary

10.1

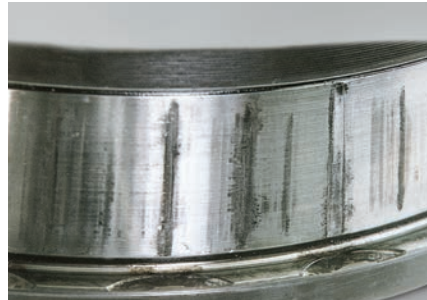

Part:
Inner ring of a double-row tapered roller bearing

Observation:
Fretting wear of raceway and stepped wear on the rib face

Cause:
Fretting progression due to excessive load while stationary

10.2



Part:
Tapered rollers of Photo 10.2

Observation:
Stepped wear on the roller head and face

Cause:
Fretting progression due to excessive load while stationary

10.3

DAMAGE CONDITION

Wear occurs due to repeated sliding between the two surfaces. Fretting occurs at fitting surface and also at contact area between raceway ring and rolling elements. Fretting corrosion is another term used to describe the reddish brown or black worn particles.

POSSIBLE CAUSE

- › Poor lubrication
- › Vibration with a small amplitude
- › Insufficient interference

COUNTERMEASURE

- › Use a proper lubricant
- › Apply a preload
- › Check the interference fit
- › Apply a film of lubricant to the fitting surface



Part:
Inner ring of a deep groove ball bearing

Observation:
Fretting occurs on the bore surface

Cause:
Vibration

11.1



Part:
Inner ring of an angular contact ball bearing

Observation:
Notable fretting occurs over entire circumference of bore surface

Cause:
Insufficient interference fit

11.2

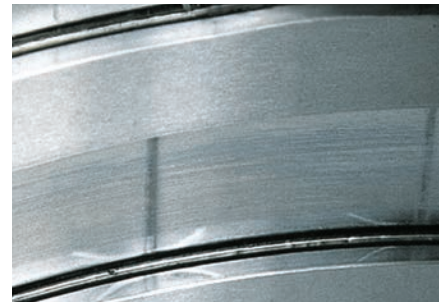

Part:
Outer ring of a double-row cylindrical roller bearing

Observation:
Fretting occurs on the raceway surface at roller pitch intervals

11.3

FALSE BRINELLING

DAMAGE CONDITION

Among the different types of fretting, false brinelling is the occurrence of hollow spots that resemble brinell dents, and are due to wear caused by vibration and swaying at the contact points between the rolling elements and raceway.

POSSIBLE CAUSE

- › Oscillation and vibration of a stationary bearing during such times as transporting
- › Oscillating motion with a small amplitude
- › Poor lubrications

COUNTERMEASURE

- › Secure the shaft and housing during transporting
- › Transport with the inner and outer rings packed separately
- › Reduce the vibration by preloading
- › Use a proper lubricant

**Part:**

Inner ring of a deep groove ball bearing

Observation:

False brinelling occurs on the raceway

Cause:

Vibration from an external source while stationary

12.1

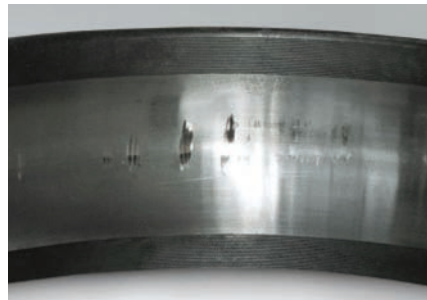
**Part:**

Outer ring of Photo 12.1

Observation:

False brinelling occurs on the raceway

Cause:

Vibration from an external source while stationary

12.2

**Part:**

Rollers of a cylindrical roller bearing

Observation:

False brinelling occurs on rolling surface

Cause:

Vibration from an external source while stationary

12.3

DAMAGE CONDITION

Creep is the phenomenon in bearings where relative slipping occurs at the fitting surfaces and thereby creates a clearance at the fitting surface. Creep causes a shiny appearance, occasionally with scoring or wear.

POSSIBLE CAUSE

- › Insufficient interference or loose fit
- › Insufficient sleeve tightening

COUNTERMEASURE

- › Check the interference, and prevent rotation
- › Correct the sleeve tightening
- › Study the shaft and housing precision
- › Preload in the axial direction
- › Tighten the raceway ring side face
- › Apply adhesive to the fitting surface
- › Apply a film of lubricant to the fitting surface



Part:
Inner ring of a spherical roller bearing

Observation:
Creep accompanied by scoring of bore surface

Cause:
Insufficient interference

13.1

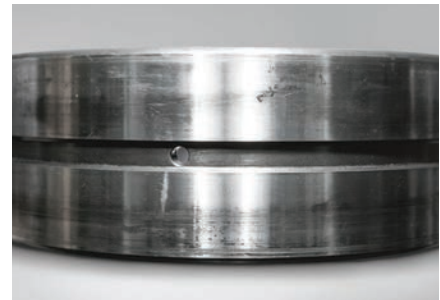

Part:
Outer ring of a spherical roller bearing

Observation:
Creep occurs over entire circumference of outside surface

Cause:
Loose fit between outer ring and housing

13.2

BEARING DAMAGE AND COUNTERMEASURES

SEIZURE

DAMAGE CONDITION

When sudden overheating occurs during rotation, the bearing becomes discolored. Next, raceway rings, rolling elements, and cage will soften, melt and deform as damage accumulates.

POSSIBLE CAUSE

- › Poor lubrication
- › Excessive load (excessive preload)
- › Excessive rotational speed
- › Excessively small internal clearance
- › Entry of water and debris
- › Poor precision of shaft and housing, excessive shaft bending

COUNTERMEASURE

- › Study the lubricant and lubrication method
- › Reinvestigate the suitability of the bearing type selected
- › Study the preload, bearing clearance, and fitting
- › Improve the sealing mechanism
- › Check the precision of the shaft and housing
- › Improve the mounting method



Part:
Inner ring of a spherical roller bearing

Observation:
Raceway is discolored and melted. Worn particles from the cage were rolled and attached to the raceway

Cause:
Insufficient lubrication

14.1



Part:
Convex rollers of Photo 14.1

Observation:
Discoloration and melting of roller rolling surface, adhesion of worn particles from cage

Cause:
Insufficient lubrication

14.2



Part:
Inner ring of an angular contact ball bearing

Observation:
Raceway discoloration, melting occurs at ball pitch intervals

Cause:
Excessive preload

14.3



Part:
Outer ring in Photo 14.3

Observation:
Raceway discoloration, melting occurs at ball pitch intervals

Cause:
Excessive preload

14.4



Part:
Balls and cage of Photo 14.3

Observation:
Cage is damaged by melting, balls become discolored and melted

Cause:
Excessive preload

14.5

ELECTRICAL EROSION

DAMAGE CONDITION

When electric current passes through a bearing, arcing and burning occur through the thin oil film at points of contact between the race and rolling elements. The points of contact are melted locally to form “fluting” or groove-like corrugations which are seen by the naked eye. The magnification of these grooves will reveal crater-like depressions which indicate melting by arcing.

POSSIBLE CAUSE

- › Electrical potential difference between inner and outer rings
- › Electrical potential difference of a high frequency that is generated by instruments or substrates when used near a bearing

COUNTERMEASURE

- › Design electric circuits which prevent current flow through the bearings
- › Insulation of the bearing



Part:
Inner ring of a tapered roller bearing

Observation:
Striped pattern of erosion occurs on the raceway surface

15.1



Part:
Tapered rollers in Photo 15.1

Observation:
Striped pattern of erosion occurs on the rolling surface

15.2



Part:
Inner ring of a cylindrical roller bearing

Observation:
Belt pattern of electrical erosion accompanied by pits on the raceway surface

15.3



Part:
Balls of a groove ball bearing

Observation:
Electrical erosion has a dark color that covers the entire ball surface

15.4



Part:
Inner ring of a deep groove ball bearing

Observation:
Fluting occurs on the raceway surface (high frequency)

15.5



Part:
Outer ring of a deep groove ball bearing

Observation:
Fluting occurs on the raceway surface (high frequency)

15.6

BEARING DAMAGE AND COUNTERMEASURES

RUST AND CORROSION

DAMAGE CONDITION

Bearing rust and corrosion are pits on the surface of rings and rolling elements and may occur at the rolling element pitch on the rings or over the entire bearing surfaces.

POSSIBLE CAUSE

- › Entry of corrosive gas or water
- › Improper lubricant
- › Formation of water droplets due to condensation of moisture
- › High temperature and high humidity while stationary
- › Poor rust preventive treatment during transporting
- › Improper storage conditions
- › Improper handling

COUNTERMEASURE

- › Improve the sealing mechanism
- › Study the lubrication method
- › Anti-rust treatment for periods of non-running
- › Improve the storage methods
- › Improve the handling method



Part:
Outer ring of a cylindrical roller bearing

Observation:
Rust on the rib face and raceway surface

Cause:
Poor lubrication due to water entry

16.1

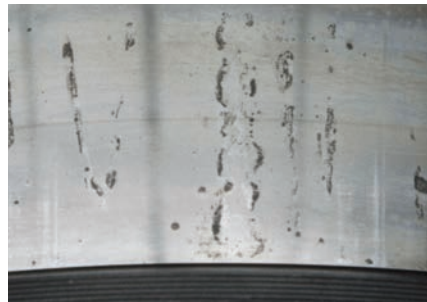

Part:
Inner ring of a spherical roller bearing

Observation:
Rust on raceway surface at roller pitch

Cause:
Entry of water into lubricant

16.2

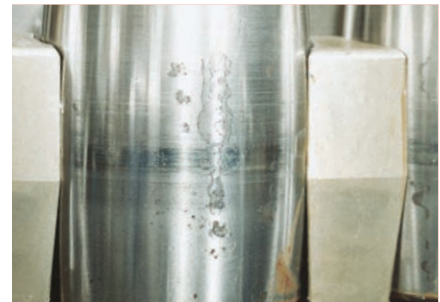

Part:
Rollers of a spherical roller bearing

Observation:
Pit-shaped rust on rolling contact surface; corroded portions

Cause:
Moisture condensation during storage

16.3

DAMAGE CONDITION

Straight line scratches on surface of raceways or rolling elements caused during mounting or dismounting of bearing.

POSSIBLE CAUSE

- › Inclination of inner and outer rings during mounting or dismounting
- › Shock load during mounting or dismounting

COUNTERMEASURE

- › Use appropriate jig and tool
- › Avoid a shock load by use of a press machine
- › Center the relative mating parts during mounting

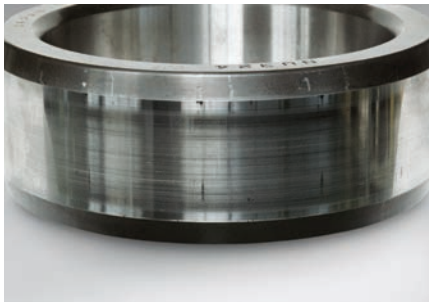

Part:
Inner ring of a cylindrical roller bearing

Observation:
Axial scratches on raceway surface

Cause:
Inclination of inner and outer rings during mounting

17.1

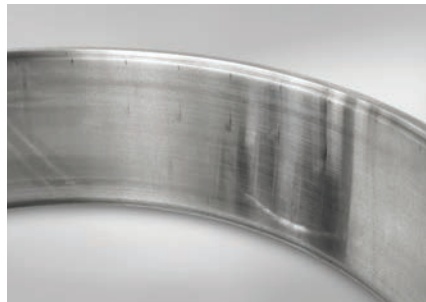

Part:
Outer ring of a double-row cylindrical roller bearing

Observation:
Axial scratches at roller pitch intervals on raceway surface

Cause:
Inclination of inner and outer rings during mounting

17.2



Part:
Rollers of a cylindrical roller bearing

Observation:
Axial scratches on rolling surface

Cause:
Inclination of inner and outer rings during mounting

17.3

BEARING DAMAGE AND COUNTERMEASURES

DISCOLORATION

DAMAGE CONDITION

Discoloration of cage, rolling elements, and raceway ring occurs due to a reaction with lubricant and high temperature.

POSSIBLE CAUSE

- › Poor lubrication
- › Oil stain due to a reaction with lubricant
- › High temperature

COUNTERMEASURE

- › Improve the lubrication method

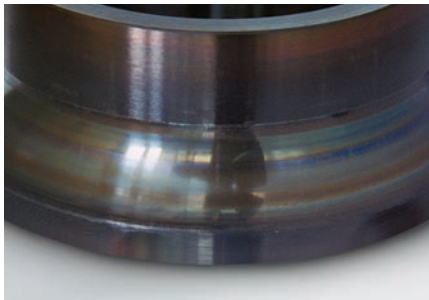

Part:
Inner ring of an angular contact ball bearing

Observation:
Bluish or purplish discoloration on raceway surface

Cause:
Heat generation due to poor lubrication

18.1

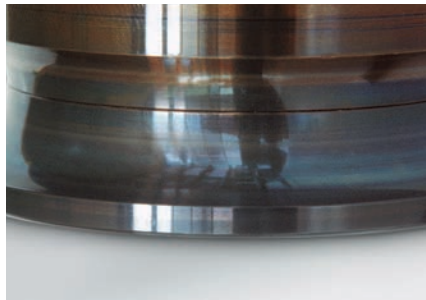

Part:
Inner ring of an angular contact ball bearing

Observation:
Bluish or purplish discoloration on raceway surface

Cause:
Heat generation due to poor lubrication

18.2

DAMAGE DIAGNOSTIC CHART



DAMAGE NAME	LOCATION (PHENOMENON)	CAUSE											REMARKS		
		Handling		Bearing surrounding			Lubrication		Load			Speed			
		Stock • Shipping	Mounting	Shaft Housing	Sealed device Water • Debris	Temperature	Lubricant	Lubrication method	Excessive load Impact load	Moment	Ultra small load	High speed, High acceleration & deceleration		Shaking • Vibration Stationary	Bearing Selection
1. Flaking (or Spalling)	Raceway, Rolling surface		•	•	•		•	•	•	•				•	
2. Scoring	Raceway, Rolling surface		•	•	•		•	•	•	•		•			
	Bearing outside surface (Rolling contact)		•		•		•	•							
3. Peeling	Roller end face surface, Rib surface				•		•	•			•	•			
	Cage guide surface, Pocket surface			•*	•		•	•							* Mating rolling part
4. Fracture	Raceway, Rolling surface	•	•	•					•	•					
5. Smearing	Raceway collar, Rollers				•		•	•			•	•			
6. Cracks	Raceway rings, Rolling elements		•	•		•			•	•					
	Rib surface, Roller end face, Cage guide surface (Thermal crack)			•				•	•	•					
7. Cage damage	Deformation, Fracture		•	•					•	•					
	Wear		•		•		•	•	•	•		•			
8. Denting	Raceway, Rolling surface, (Innumerable small dents)				•			•							
	Raceway (Dents on the rolling element pitch)	•	•						•				•		
9. Pitting	Raceway, Rolling surface				•		•	•							
10. Wear	Raceway, Rolling surface, Rib surface, Roller end face		•		•		•	•							
11. Fretting	Raceway, Rolling surface	•	•	•			•	•	•			•	•		
	Bearing outside & bore, side surface (Contact with housing and shaft)		•	•					•						
12. False brinelling	Raceway, Rolling surface	•					•	•					•		
13. Creep	Fitting surface		•	•		•	•*	•*	•			•			* Clearance fit
14. Seizure	Raceway ring, Rolling element, Cage		•	•	•		•	•	•	•		•		•	
15. Electrical erosion	Raceway, Rolling surface		•*	•*											* Electricity passing through the rolling element
16. Rust and corrosion	Raceway ring, Rolling element, Cage	•	•		•	•	•	•							
17. Mounting flaws	Raceway, Rolling surface		•	•											
18. Discoloration	Raceway ring, Rolling element, Cage					•	•	•							



7 8 9
ABC DEF
4 5 6
GHI JKL MNO
1 2 3
PQRS TUV WXYZ
0 . +/-

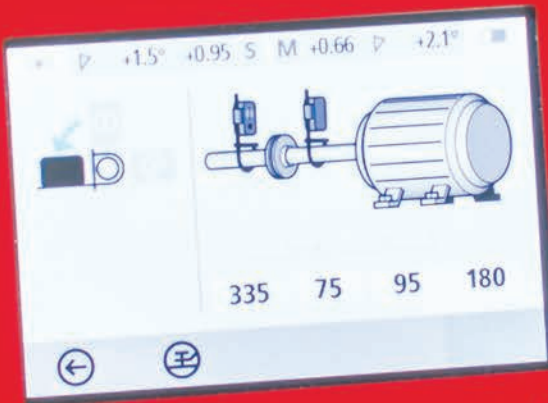

< OK >
^
v

MOTION & CONTROL
NSK

LAS-Set
Laser Alignment Tool - Shaft



A dark, grayscale background image of industrial machinery, possibly a motor or a large piece of equipment, is visible on the left side of the page. The image is partially obscured by the text and the table of contents.

SECTION F:

MAINTENANCE TOOLS / TECHNICAL SUPPORT

MAINTENANCE TOOLS	F3
TECHNICAL SUPPORT	F4
ENGINEERING SUPPORT	F4
NSK AMERICAS TECHNICAL CENTER	F4
TECHNICAL ON-SITE SUPPORT	F5
TECHNICAL ON-LINE SUPPORT	F5
TRAINING PROGRAMS	F6

MAINTENANCE TOOLS

The cause of premature bearing failure can often be diagnosed as a result of incorrect handling and installation. Since rolling bearings are high precision machine parts, they must be handled accordingly. Their expected performance cannot be achieved if they are not handled properly. A simple precaution to observe is the consistent use of proper tools and equipment when handling bearings, avoiding the use of general-purpose tools.



NSK offers a wide range of mechanical and alignment tools to assist with proper bearing handling and installation, including:

Mechanical Tools for Handling, Mounting and Dismounting

- › Induction heaters
- › Pullers and pushers
- › Bearing lifting tools
- › Press plates
- › Fitting tools
- › Hydraulic nuts
- › Sine bars



Alignment Tools

- › Laser shaft alignment tool
- › Laser belt alignment tool

In addition to offering the tools and equipment, NSK will provide an on-site demonstration of appropriate use of the equipment.



TECHNICAL SUPPORT

ENGINEERING SUPPORT

Proper bearing selection can have a major impact on our customers' entire business, helping to achieve improvements in machine reliability, productivity and performance, all of which carry a tangible and measurable cost benefit. Identifying optimal solutions is an expertise of NSK's application engineers, who work hand in hand with our customers from the original machine design stage to the resolution of performance issues.

With a foundation of industry, machine, and operating condition experience, NSK application engineers support our customers with a range of services including:

- › **Application reviews**
- › **Machine design support**
- › **OEM part conversion**
- › **Diagnostics**
- › **Bearing condition analysis**
- › **Failed bearing analysis**
- › **Lubrication analysis**

Our engagement with our customers doesn't end with a report of our findings or recommended solutions. We monitor performance to ensure anticipated results and utmost performance are being delivered.

AMERICAS TECHNICAL CENTER

NSK's global network of research centers are linked together in our focus on the development of new technologies, and the continuous optimization of quality of NSK products. At the core of our research activities is the development of advanced material and lubricant technologies, simulation applications using a variety of analytical systems, and technological innovation in the field of mechatronics. At the heart of our work is absolute customer satisfaction with, and benefit from, NSK products.



The NSK Americas Technical Center, located in Ann Arbor MI, utilizes a variety of analytical systems and technological innovation to conduct considerable research, testing and analysis including:

- › **Bearing test lab** for fatigue life, seal testing, environmental simulation testing, as well as design and product verification
- › **Visual analysis** of failure and fracture using digital photography and measurement
- › **Metrology** using dimensional, coordinate and form measurements
- › **Chemical analysis** using scanning electron microscope, compound analysis and particle counting
- › **Metallurgical evaluation** of the microstructure and macrostructure, as well as hardness measurements, case depth measurements, heat treatment verification, fractography and steel cleanliness evaluation
- › **Noise and vibration assessments** using internally developed software and equipment, in addition to advanced analysis tools such as Fast Fourier Transform (FFT), enveloping, and bearing fault frequencies

TECHNICAL SUPPORT

TECHNICAL ON-SITE SUPPORT

Improvement is a journey without an end destination. It never stops. And we never stop looking for better ways of supporting our customers in a comprehensive, collaborative, and continuous way. The focus of NSK industry specialists isn't simply on a quick-fix and immediate gain – it's about incremental and sustainable improvement to deliver long-term benefits.

When NSK is on-site, we're there to understand our customers' challenges and identify problems leading to frequent bearing replacement, breakdowns caused by poor specification, high energy costs from inefficient product selection and lost production because of downtime. We use our learning, knowledge and experience to collaborate with our customers to implement improvements that deliver measurable value in terms of performance, productivity and maintenance cost efficiency.

Our collaboration with customers is holistic, with a range of services and support that includes:

- › **Process mapping**
- › **Inventory / critical spares management**
- › **Bearing installation and removal**
- › **Scheduled maintenance programs**
- › **Inspection and diagnostics**
- › **Best maintenance practice training**

With NSK on-site support, our customers take a critical step forward in realizing improvements in equipment, productivity, people and financial performance.



TECHNICAL ON-LINE SUPPORT

For the technically self-sufficient and independent problem-solver, NSK offers extensive on-line resources to facilitate design, selection and troubleshooting including:

- › Bearing selection catalog (including app)
- › CAD file download
- › Bearing calculation tools (including app)
 - › bearing life
 - › fits and clearances
 - › frequencies
 - › lubrication viscosities and intervals
 - › frictional moment and speeds
- › Troubleshooting (Bearing Doctor) app
- › NSK Verify app for machine tool bearings

Visit nskamericas.com.

TRAINING PROGRAMS

NSK offers a range of training opportunities designed to expand on the knowledge required in daily work and to contribute to optimizing NSK bearing performance, as well as machinery and equipment performance. Our programs include a large variety of well-proven courses that focus on the major learning needs of those involved in specifying, ordering and installing and maintaining bearings. Our instructors are application engineers, industry specialists and service engineers with vast technical expertise and an understanding of specific industry sector demands. The combination of theoretical and practical training ensures successful learning outcomes for our customers.

Training opportunities available from NSK range from the regular recurring **Bearing Boot Camp** programs held at our NSK Americas headquarters to customizable on-site training to our web-based **NSK Academy**.

› **Bearing Boot Camp**

is held each spring and fall at NSK Americas headquarters in Ann Arbor, MI. Basic and advanced programs are offered.

Bearing Basics - offers an introduction to bearing types, design features, performance characteristics and nomenclature. Effectively using available resources such as online bearing selection, calculation and lubrication tools is also included.

Advanced Class - is tailored to individuals working in a decidedly hands-on capacity with rolling bearings and includes an understanding of parameters for calculating bearing selection, shaft and housing fits, and lubrication fill and replenishment.

› **On-Site Training**

is typically defined by and designed to meet the needs of customers. The training is tailored specifically to the applications and products unique to their industry, and will typically include relevant:

- › Bearing types, design features, performance characteristics and nomenclature
- › Examples of bearing applications and mounted bearing arrangements
- › Bearing selection, lubrication, fits and calculations
- › Hands-on interaction with bearing installation demos and appropriate mechanical tools

› **NSK Academy**

is available on-line with a wide range of technical tutorials to introduce the user to basic bearing types, their design features and their performance characteristics as they relate to friction, torque, loads and other acting forces. Additional modules for bearing handling, troubleshooting and use of maintenance tools are also available.

Visit nskacademy.com.



IMPROVEMENT PAYS

END-TO-END SERVICE DELIVERS CUSTOMER SUCCESS

Improvement never ends. And we never stop looking for better ways to support our customers in a complete, collaborative and continuous way. The focus of NSK isn't simply on a quick fix for immediate gain – it's about incremental and sustainable improvement to deliver long-term benefits.

When NSK is on-site, we're there to understand our customers' challenges and identify problems contributing to frequent bearing replacement, breakdowns caused by poor specification, high energy costs from inefficient product selection and lost production because of downtime. We collaborate with our customers to institute an **Asset Improvement Program (AIP)** that encompasses process and maintenance management, diagnostic and educational support to deliver measurable gains in output and cost-efficiency.

With NSK, our customers embark on a critical path to realizing improvements in equipment, productivity, people and financial performance.





NSK AMERICAS

United States
NSK Corporation
Ann Arbor MI
1.888.446.5675

Canada
NSK Canada Inc.
Brampton ON
1.905.890.9740

Mexico
NSK Rodamientos Mexicana,
S.A. de C.V.
Silao Guanajuato MX
52.472.500.9500

Brazil
NSK Brasil Ltda.
Suzano SP
55.11.4744.2500

Argentina
NSK Argentina SRL
Buenos Aires
54.11.4704.5100

Latin America
NSK Latin America Inc.
Miramar FL
1.305.477.0605

Website: www.nsk.com/am-en
NSK Global: www.nsk.com

Every care has been taken to ensure the accuracy of the data contained in this catalog, but no liability can be accepted for any loss or damage suffered through errors or omissions.

Printed in the USA ©NSK 2025.
The contents of the publication are the copyright of the publishers.